

GlazeArt2018

International Conference

Glazed Ceramics in Cultural Heritage

Editors

Silvia Pereira

Marluci Menezes

José Delgado Rodrigues





LABORATÓRIO NACIONAL
DE ENGENHARIA CIVIL



IPERION CH

GlazeArt2018

International Conference
Glazed Ceramics in Cultural Heritage

Proceedings

Edited by Sílvia Pereira, Marluce Menezes & José Delgado Rodrigues
LNEC, Lisbon, 29-30 October, 2018

Legal Notice

The scientific quality and content of the papers published herein are of the entire responsibility of their authors. Therefore, the publisher accepts no responsibility or liability whatsoever with regard to the information contained in this publication.

The total or partial reproduction, and any representation of the substantial or partial content of the present publication, by any process or means whatsoever, including copy or transfer, without the express consent of the publisher, is prohibited and constitutes an infringement sanctioned by the Law.

Copyright © LABORATÓRIO NACIONAL DE ENGENHARIA CIVIL, I. P.
Divisão de Divulgação Científica e Técnica
AV DO BRASIL 101 • 1700-066 LISBOA
e-e: livraria@lnec.pt
www.lnec.pt

Editor: LNEC

Coleção: Reuniões Nacionais e Internacionais

Série: RNI 104

1ª edição: 2018

Tiragem: 100 exemplares

Descriptors: Cultural heritage / Architectural heritage / Glazed ceramics / Azulejo / Ceramic cladding / International congress

Descritores: Património cultural / Património arquitetónico / Cerâmica vidrada / Azulejo / Revestimento cerâmico / Congresso internacional

CDU 691.4:72.025.2/.4(063)(100)

ISBN 978-972-49-2301-7

Preface

The majolica technique is an Islamic heritage whose technology flowed from the Middle East to Iberia, then to Italy, where it evolved and flowered during the Renaissance, and from there back to Spain and to Antwerp from where it irradiated throughout Europe. In decadence as an art medium in the second half of the 16th century, majolica had a surprising flowering in Portugal precisely at that time in a particularly demanding avatar as wall linings, and the pillars of the Portuguese predilection for majolica azulejos started being grounded. After a century of evolution through a succession of styles, full linings in cobalt blue over the white tin glaze were again promoted to the status of art in Portugal at the close of the 17th century, when artists started painting and signing azulejo panels masterfully integrated in the Baroque interiors - maybe the most original Portuguese contribution to the art heritage of Europe.

Movable Italian maiolica art is supremely beautiful but for glazed ceramics to be integrated architecturally, a whole new set of problems materialize. Majolica linings are an artist's dream and an engineer's nightmare. A dream because the pigments used to paint them become sealed in glass and potentially forever lasting and shiny; a nightmare because they go against the most basic recommendations an engineer would put forward about a construction material. Laminated materials are problematic because their properties change abruptly, which is always a source of concern for the engineer. But glazed ceramics such as azulejos take that proposition to extremes by lining a very porous ceramic material that tends to expand by absorbing humidity with impermeable glass that does not expand at all and totally cuts the vapour transmission from the wall to the environment. Glazed ceramics for architectural integration are a summit of achievement of try-and-error technology that does not cease to amaze those who dwell into its technical intricacies.

This duality of art content and its material embodiment calls for a co-operation between the Art Historian and the Materials Engineer and that was the ground for the fruitful understanding established in 2009 between the Museu Nacional do Azulejo (the National Azulejo Museum of Portugal) and the Laboratório Nacional de Engenharia Civil (LNEC - the National Laboratory for Civil Engineering) which frames the organization of the present event. The recent project FCT-AzuRe funded by the Portuguese Foundation for Science and Technology involves also the HERCULES Laboratory of the University of Evora and the contributions of five different specialized approaches that led to the first scientific instrumental-based probe into the early establishment of azulejo workshops in Lisbon. Some results of that project will be disclosed in this conference.

The organization is also a joint effort of the European Project IPERION CH and the National Research Infrastructure on cultural heritage E-RIHS.pt that called for a decisive effort from the members of both the Organizing and the Scientific Committees and to all their members goes our heartfelt thanks. LNEC staff is acknowledged for the local organization and support to the conference. Last but indeed not least, our appreciation goes to all authors whose contributions are the body of the Conference.

GlazeArt 2018 follows the successful GlazeArch 2015 and affirms our aim to organize a string of conferences to help expand the network of co-operations towards the understanding and preservation of not only azulejos or majolica, but the whole glazed ceramics heritage.

João Manuel Mimoso

Organizing Committee

João Manuel Mimoso (LNEC, IPERION CH, FCT-AzuRe) – chair

Maria Antónia Pinto de Matos (MNAz) – co-chair

Alexandre Pais (MNAz, FCT-AzuRe) – co-chair

Luca Pezzati (CNR, IPERION CH, Italy)

Thais Caminha Sanjad (UFPA, LACORE, Brazil)

Jaume Coll Conesa (National Ceramic Museum, Spain)

Rosário Salema de Carvalho (Az-Rede / ARTIS – Lisbon University)

Antonio Candeias (HERCULES- U. Evora, FCT-AzuRe)

Marluci Menezes (LNEC, IPERION CH)

Sílvia Pereira (LNEC, FCT-AzuRe)

Dória Costa (LNEC, IPERION CH)

M. Augusta Antunes (LNEC, FCT-AzuRe)

Scientific Committee of Reviewers

J. Delgado Rodrigues (LNEC, IPERION CH) – chair

Alexandre Pais (MNAz, FCT-AzuRe) – co-chair

Jaume Coll Conesa (National Ceramic Museum, Spain)

Thais Caminha Sanjad (UFPA, LACORE, Brazil)

Rosário Salema de Carvalho (Az-Rede / ARTIS – Lisbon University)

Kate van Lookeren Campagne (Amsterdam University, The Netherlands)

João Manuel Mimoso (LNEC, IPERION CH, FCT-AzuRe)

Marluci Menezes (LNEC, IPERION CH)

Sílvia Pereira (LNEC, FCT-AzuRe)

Dória Costa (LNEC, IPERION CH)

Lurdes Esteves (MNAz, FCT-AZURE)

Index of Abstracts

Signatures and authorial marks on Portuguese azulejos (16 th -18 th centuries) [full article]	1
<i>Rosário Salema de Carvalho, Francisco Queiroz</i>	
Study on the Relationship between Chinese Blue and White Porcelain and Portuguese Azulejos	3
<i>Liu Yang, Dongliang Lyu</i>	
Pottery from Nishapur: Kunstvollen of Iranians [full article]	5
<i>Anna Kholomeeva</i>	
Tiles in the Museum of Civil Engineering [full article]	7
<i>Alcinea Zita Sampaio</i>	
The use of “Tijomel” tiles in Portuguese modern architecture [full article]	9
<i>Catarina F. M. Geraldes, João Manuel Mimoso, Alexandre Pais</i>	
Technical identification of the earliest productions of faience tiles in Lisbon	11
<i>João Manuel Mimoso, Maria Augusta Antunes, Sílvia R. M. Pereira, Maria de Lurdes Esteves, Ana Margarida Cardoso, António Candeias, Alexandre Pais</i>	
Analytical study of the azulejos from Igreja da Graça in Lisbon, signed by João de Góis	13
<i>João Manuel Mimoso, Alexandre Pais, Maria de Lurdes Esteves, Miguel Ângelo Silva, Ana Margarida Cardoso, Maria Augusta Antunes, Sílvia R. M. Pereira and António Candeias</i>	
The 16 th century nativity azulejo panel called “de Nossa Senhora da Vida”	15
<i>Alexandre Pais, Maria Antónia Pinto de Matos, João Manuel Mimoso, Maria de Lurdes Esteves, Ana Margarida Cardoso, António Candeias</i>	
The lost azulejo panel once in the Church of Santo André, near Graça, in Lisbon	17
<i>Alexandre Pais, Victor Filipe, João Manuel Mimoso, Maria de Lurdes Esteves, Maria José Sequeira, Ana Margarida Cardoso</i>	
The azulejos in the <i>Capela de São Roque</i> in Lisbon	19
<i>Alexandre Pais, Teresa Morna, João Miguel Simões, João Manuel Mimoso, Maria de Lurdes Esteves, Ana Margarida Cardoso, Sílvia R. M. Pereira, António Candeias</i>	
An unknown jigsaw in the Cathedral of Setúbal	21
<i>Alexandre Pais, Pe. Rui Rosmaninho, João Manuel Mimoso, Maria de Lurdes Esteves and Ana Margarida Cardoso</i>	
Degradation of Egyptian faience shabti produced with exterior glazing methods	23
<i>Corinna de Regt, Luc Megens, Mandy Slager</i>	
Influence of the production technology on the morphological characteristics of azulejos [full article]	25
<i>Sílvia R. M. Pereira, Maria Augusta Antunes, Ana Margarida Cardoso, Mafalda Costa, José Delgado Rodrigues, Maria de Lurdes Esteves, José Mirão, António Candeias, João M. Mimoso</i>	
Glaze composition of 17 th - 18 th century Dutch Delftware	27
<i>Annelies van Hoesel, Neha Verma, Jolanda van Iperen and Femke Diercks</i>	
Understanding 17-18 th century Dutch tin-glaze through the interpretation and reconstruction of historical recipes [full article]	29
<i>Kate van Lookeren Campagne, Luc Megens, Maarten van Bommel</i>	
Improving data exploration methods from macro imaging techniques: in situ scanning macro-XRF investigation on a majolica tile tableau [full article]	31
<i>Marco Colombo, Stijn Legrand, Geert Van der Snickt, Koen Janssens</i>	

Mortars for the reattachment of old tiles: characteristics needed for preservation of azulejos claddings [full article]	33
<i>Maria do Rosário Veiga</i>	
Studies on Azulejo glaze welding by means of laser irradiation [full article]	35
<i>Sílvia R. M. Pereira, Kostas Hatzigiannakis, Eleni Polychronaki, Kristallia Melessanaki, Paraskevi Pouli and João M. Mimoso</i>	
Validation of contactless vibro-acoustic imaging for the detection of glaze delamination in glazed ceramic tiles [full article]	37
<i>Paola Calicchia, Sara De Simone, Simone Privitera</i>	
The implementation of computer-match pigment selection for overcoming metamerism in ceramic glaze reinstatement [full article]	39
<i>Norman H. Tennent, Isabelle Garachon, James H. Nobbs, Mandy Slager, Bouke de Vries</i>	
Biodeterioration of glazed tiles: case studies and novel laboratory-based approaches [full article]	40
<i>Mathilda L. Coutinho, Ana Z. Miller, Maria Filomena Macedo</i>	
A first approach to the tile collection from the Convento de Santana (Lisbon, Portugal) [full article]	42
<i>Mariana Almeida, Rosa Varela Gomes, Mário Varela Gomes</i>	
Lead glazed ceramics in Lisbon (16th-18th centuries) [full article]	45
<i>Tânia Manuel Casimiro, José Pedro Henriques, Vanessa Filipe, Carlos Boavida</i>	
The 17th-century tile panorama in the island of Santiago, Cabo Verde: a first approach to a work in progress [full article]	47
<i>Mariana Almeida</i>	
16th century azulejos what lies beneath the ground of Lisbon? [full article]	49
<i>Alexandre Pais, Maria José Sequeira, Maria de Jesus Monge, Maria de Lurdes Esteves, Inês Castanheira, António Valongo, Cláudia Manso, Victor Filipe, Ana Margarida Cardoso, João Manuel Mimoso</i>	
Conservation and restoration of the tile collection of Quinta Nova, Torres Vedras - Criteria and technique [full article]	51
<i>Ricardo Triães, Ânia Chasqueira, Catarina Melo</i>	
The earliest stencilled azulejos lining the façades of Lisbon	53
<i>Joana Campelo, João Manuel Mimoso, Alexandre Pais</i>	
Lookouts and outlooks: Lisbon, tiles and topography [full article]	55
<i>Helena Cunha Lopes, Rui Matos, Joaquim Marcelino Santos</i>	
The use of modern azulejos and panels in Portuguese shop fronts [full article]	58
<i>Catarina F. M. Geraldes, João Manuel Mimoso, Alexandre Pais</i>	
No Secret Beyond the Door: the Rampa store and its doorframe, a collaboration between Querubim Lapa and Conceição Silva, 1956 [full article]	60
<i>Rita Gomes Ferrão</i>	
Tracing the provenance of tin-glazed ceramics in the Netherlands	62
<i>Luc Megens, Madelon Pronk, Simone Casale</i>	
A new 15th-16th century pottery kiln on the Tagus basin, Alenquer, Portugal	64
<i>L.F. Vieira Ferreira, I. Ferreira Machado, T. M. Casimiro</i>	
Beneath sacred land: glazed pottery from the old Church of La Concepción in Zamora [full article]	66
<i>Uxue Sanchez-Garmendia, Estefania Calparsoro, Gorka Arana, Javier G. Iñañez</i>	

Villafeliche an 18th century majolica producing village in the heart of Aragon (Spain) [full article]	69
<i>Javier G. Iñáñez</i>	
SEM-EDS research on mineral inclusions found in the biscuit of azulejos as a tool for provenance studies [full article]	72
<i>João Manuel Mimoso, Dória Rodrigues Costa, Maria Augusta Antunes, Ana Margarida Cardos, Maria de Lurdes Esteves, José Mirão, Alexandre Pais</i>	
Underglaze-decorated tin-opacified tiles from the 15th-16th-century Iberian Peninsula	74
<i>Susana Coentro, Luís C. Alves, Jaume Coll Conesa, Teresa Ferreira, José Mirão, Rui C. da Silva, Rui Trindade, Solange Muralha</i>	
Portuguese Blue-on-Blue 16th-17th c. Pottery	76
<i>I. Ferreira Machado, L.F. Vieira Ferreira, T. M. Casimiro</i>	
The tile work of Jorge Colaço in workshop. From the order to the final artwork. The case study of S. Bento's railway station in Porto- Portugal	78
<i>Cláudia Emanuel, Eduarda Vieira, Maria de Lurdes Esteves</i>	
Apeiron - ἄπειρον - and Havoc: Beauty in Aalto's tiles [full article]	79
<i>Joaquim Marcelino Santos</i>	
Chemical Characterization of the glassy phase of glazes from 17th century majolica azulejos [full article]	81
<i>Augusta Lima, Carlo Pantano</i>	
On the use of glaze and ceramic body analytical spectra in heritage azulejos as beacons of provenance [full article]	82
<i>João Manuel Mimoso, Maria Augusta Antunes, Sílvia R. M. Pereira, António Candeias, Alexandre Pais</i>	
Unknown Porto - the use of azulejos in the modern architecture of the northern Portuguese town [full article]	84
<i>Catarina F. M. Gerales, João Manuel Mimoso, Alexandre Pais</i>	
Biodeterioration of glazed tiles by lichens	86
<i>Mathilda L. Coutinho, Ana Teresa Caldeira, Ana Z. Miller, Cesareo Saiz-Jimenez, Antonio Gómez-Bolea, Maria Filomena Macedo, João Pedro Veiga, Augusta Lima</i>	

Index of Full Articles

Signatures and authorial marks on Portuguese azulejos (16th-18th centuries)	91
<i>Rosário Salema de Carvalho, Francisco Queiroz</i>	
Pottery from Nishapur: Kunstwollen of Iranians	110
<i>Anna Kholomeeva</i>	
Tiles in the Museum of Civil Engineering	116
<i>Alcília Zita Sampaio</i>	
The use of "Tijomel" tiles in Portuguese modern architecture	125
<i>Catarina F. M. Geraldes, João Manuel Mimoso, Alexandre Pais</i>	
Influence of the production technology on the morphological characteristics of azulejos	140
<i>Sílvia R. M. Pereira, Maria Augusta Antunes, Ana Margarida Cardoso, Mafalda Costa, José Delgado Rodrigues, Maria de Lurdes Esteves, José Mirão, António Candeias, João M. Mimoso</i>	
Understanding 17-18th century Dutch tin-glaze through the interpretation and reconstruction of historical recipes	150
<i>Kate van Lookeren Campagne, Luc Megens, Maarten van Bommel</i>	
Improving data exploration methods from macro imaging techniques: in situ scanning macro-XRF investigation on a majolica tile tableau	165
<i>Marco Colombo, Stijn Legrand, Geert Van der Snickt, Koen Janssens</i>	
Mortars for the reattachment of old tiles: characteristics needed for preservation of azulejos claddings	185
<i>Maria do Rosário Veiga</i>	
Studies on Azulejo glaze welding by means of laser irradiation	194
<i>Sílvia R. M. Pereira, Kostas Hatzigiannakis, Eleni Polychronaki, Kristallia Melessanaki, Paraskevi Pouli and João M. Mimoso</i>	
Validation of contactless vibro-acoustic imaging for the detection of glaze delamination in glazed ceramic tiles	208
<i>Paola Calicchia, Sara De Simone, Simone Privitera</i>	
The implementation of computer-match pigment selection for overcoming metamerism in ceramic glaze reinstatement	227
<i>Norman H. Tennent, Isabelle Garachon, James H. Nobbs, Mandy Slager, Bouke de Vries</i>	
Biodeterioration of glazed tiles: case studies and novel laboratory-based approaches	238
<i>Mathilda L. Coutinho, Ana Z. Miller, Maria Filomena Macedo</i>	
A first approach to the tile collection from the Convento de Santana (Lisbon, Portugal)	251
<i>Mariana Almeida, Rosa Varela Gomes, Mário Varela Gomes</i>	
Lead glazed ceramics in Lisbon (16th-18th centuries)	268
<i>Tânia Manuel Casimiro, José Pedro Henriques, Vanessa Filipe, Carlos Boavida</i>	
The 17th-century tile panorama in the island of Santiago, Cabo Verde: a first approach to a work in progress	283
<i>Mariana Almeida</i>	
16th century azulejos what lies beneath the ground of Lisbon?	298
<i>Alexandre Pais, Maria José Sequeira, Maria de Jesus Monge, Maria de Lurdes Esteves, Inês Castanheira, António Valongo, Cláudia Manso, Victor Filipe, Ana Margarida Cardoso, João Manuel Mimoso</i>	
Conservation and restoration of the tile collection of Quinta Nova, Torres Vedras - Criteria and technique	313
<i>Ricardo Triães, Ânia Chasqueira, Catarina Melo</i>	

Lookouts and outlooks: Lisbon, tiles and topography	323
<i>Helena Cunha Lopes, Rui Matos, Joaquim Marcelino Santos</i>	
The use of modern azulejos and panels in Portuguese shop fronts	337
<i>Catarina F. M. Geraldes, João Manuel Mimoso, Alexandre Pais</i>	
No Secret Beyond the Door: the Rampa store and its doorframe, a collaboration between Querubim Lapa and Conceição Silva, 1956	347
<i>Rita Gomes Ferrão</i>	
Beneath sacred land: glazed pottery from the old Church of La Concepción in Zamora	361
<i>Uxue Sanchez-Garmendia, Estefania Calparsoro, Gorka Arana, Javier G. Iñañez</i>	
Villafeliche an 18th century majolica producing village in the heart of Aragon (Spain)	380
<i>Javier G. Iñañez</i>	
SEM-EDS research on mineral inclusions found in the biscuit of azulejos as a tool for provenance studies	393
<i>João Manuel Mimoso, Dória Rodrigues Costa, Maria Augusta Antunes, Ana Margarida Cardos, Maria de Lurdes Esteves, José Mirão, Alexandre Pais</i>	
Apeiron - ἄπειρον - and Havoc: Beauty in Aalto's tiles	410
<i>Joaquim Marcelino Santos</i>	
Chemical Characterization of the glassy phase of glazes from 17th century majolica azulejos	430
<i>Augusta Lima, Carlo Pantano</i>	
On the use of glaze and ceramic body analytical spectra in heritage azulejos as beacons of provenance	439
<i>João Manuel Mimoso, Maria Augusta Antunes, Sílvia R. M. Pereira, António Candeias, Alexandre Pais</i>	
Unknown Porto - the use of azulejos in the modern architecture of the northern Portuguese town	451
<i>Catarina F. M. Geraldes, João Manuel Mimoso, Alexandre Pais</i>	

Signatures and authorship marks on Portuguese *azulejos* (16th-18th centuries)

Rosário Salema de Carvalho¹ and Francisco Queiroz²

¹ *Az – Rede de Investigação em Azulejo, ARTIS – Instituto de História da Arte, Faculdade de Letras da Universidade de Lisboa, Lisbon, Portugal, rscarvalho@letras.ulisboa.pt*

² *Az – Rede de Investigação em Azulejo, ARTIS – Instituto de História da Arte, Faculdade de Letras, Universidade de Lisboa, Lisboa, Portugal, correio@franciscoqueiroz.com*

SUMMARY

In the early 20th century, the authorship of the Portuguese *azulejo* (glazed tile) was widely discussed by Art History. Liberato Telles¹, José Queirós² and Vergílio Correia³ were some of the authors who, at an early stage of the tile studies, were more concerned with collecting lists of signed and dated *azulejos*. The compilation of signatures and related records allowed for the creation of artistic *corpora* that still help researchers in what concerns attributions, thus progressively increasing the number of works associated to each painter. Nevertheless, the studies on Portuguese *azulejos* rarely explore all the information about signatures and authorship marks, in order to overcome the mere identification of the author and the year.

Indeed, even at an international level, many authors argue that the issue of signatures has never been properly explored by Art History⁴. However, this does not fully correspond to reality, as there are several reference articles on this subject discussing this particularly rich and complex phenomenon, which is that of signatures in painting.

Returning to the *azulejo*, the present paper is part of a much wider approach aiming encompass a deeper analysis on signatures in Portuguese *azulejos* within a time period running from the beginning of the 16th century to the first decades of the 20th century⁵. The choice of such a wide time-span will allow us to compare the common practice of the artists' workshops of the Modern Age, in terms of authorship, granting us the opportunity to clearly identify periods with a larger number of signed tileworks, in contrast to others for which almost no authorial marks are known. Moreover, this long period of time allows us to propose a correlation between the greater or lesser presence of signed tileworks with the typologies of *azulejo* coverings that were predominant in each epoch and the inherent production practices. Also, it leads to issues of painters' social status as well as of the artistic and cultural context. However, due to the constraints of an article, we will move only one step forward by systematizing the identification of variations, abbreviations, numbers, Latinizations, ornaments or complementary expressions from the beginning of the 16th century to the middle of the 18th century. All the information used is available online, organized in photographic albums and in a timeline, thus contributing to different and new data visualisations⁶.

As we explore along the full article, the signatures or the authorial marks are, as expected, only associated with figurative coverings: in a first stage only with imported tiles and what is conventionally designated as the first Portuguese production, in the Mannerist taste; and, already in the last quarter of 17th century, related to the great narrative cycles executed in blue and white colours.

The older marks – the monograms – are certainly rooted in a tradition linked to Northern Europe, and the names of the authors are progressively unfolded. At the end of the 17th century, Gabriel del Barco signed a large number of coverings, and he is the painter with more works associated to his signature, using different variants. Like the painters of the next cycle, known as the

Masters' Cycle, the assumption of an authorial mark and the desire for authorship recognition seems obvious. If the so-called Master P.M.P. seems to use only an acronym almost as if it were a stamp, others use the handwriting closest to the signatures that can be compared with archival documents. Still others, such as the Bernardes family, Latinize the names and surnames, certainly as a form of association with classical and Roman tradition and a more erudite universe, exemplified by the “*pinxit*” expression used by Policarpo in Viana do Castelo or, more generalized, the Latin form of *facere* – *fecit*. As the 18th century progresses, the signed works are in much smaller number and interestingly all the few signers were disciples of António de Oliveira Bernardes. In fact, the cycle of the so-called *Great Joanine Production* did not favour the individualization of painting, and in the mid-18th century signatures tended to disappear from Portuguese *azulejos*.

Concluding, in spite of the different questions that still require an answer and concerning the situation of painters as well as the recognition of painting as a liberal art, the apposition of the signatures observed is indicative of an authorial intention, and reveals an attitude towards the work, whether is it conscious or not of an artistic personality. On the other hand, and as we stated, this article aims to systematize the known signatures on *azulejos* of the first Portuguese majolica production and the Baroque period, but broader research is required in which the comparison with the signatures and authorship marks present on tiles produced in other European centres is crucial.

Key-words: *Azulejos (tiles), painters, signatures, Portugal*

ACKNOWLEDGMENTS

This study was financed by Fundação para a Ciência e Tecnologia (FCT-Portugal) with a postdoctoral grant (SFRH/BPD/84867/2012) owned by the first author, supported by the European Social Fund through the Human Capital Operational Programme (HCOP), and by national funds from the Ministry of Science, Technology and Higher Education.

BIBLIOGRAPHIC REFERENCES

- ¹ TELLES, Liberato – *Duas palavras sobre pavimentos*. Typographia da Companhia Nacional Editora, Lisboa, 1896.
- ² QUEIRÓS, José – *Cerâmica Portuguesa e outros estudos*. 4^a ed. Lisboa: Editorial Presença, 2002 [1907].
- ³ CORREIA, Vergílio – *Azulejos*. Livraria Gonçalves, Coimbra, 1956. Publicação original da obra *Azulejos* Dados em 1916 e 1922.
- ⁴ GILBERT, Creighton – *A preface to signatures (with some cases in Venice)*. Fashioning Identities in Renaissance Art, edited by Mary Rogers, Ashgate, 2000, 79-87.
- ⁵ This study includes a psychological approach, based on the same methodologies used by graphologists and forensic experts, in order to complement the traditional procedures of Art History.
- ⁶ See <https://azinfinitum.wixsite.com/signatures>

Study on the Relationship between Chinese Blue and White Porcelain and Portuguese Azulejos

Yang Liu¹, Dongliang Lyu²

¹ *Charles University, Faculty of Humanities, Prague, Czech Republic, MAGGIEliuyang1989@gmail.com*

² *Charles University, Faculty of Humanities, Prague, Czech Republic, ldl890901@gmail.com*

SUMMARY

Azulejo is a Portuguese word which describes a square ceramic plaque with decorated glaze on one of its surfaces. Although azulejos do not originate from Portugal their extensive and uninterrupted use for over five centuries, covering surfaces on both the inside and outside of buildings, testifies to the fact that they have become representative of the developments in Portuguese art during the past 500 years.

In the 16th century, the ceramic industry in Europe was relatively backward. Blue-and-white porcelain started to be favored by European society once its import had begun. The complicated patterns of Chinese blue-and-white porcelain have obvious Islamic influences in the Yuan dynasty and the first half of Ming dynasty. The azulejos used in Portugal in the first half of the 16th century were produced in Spain. The motives of Portuguese azulejos could have similar patterns to those of Ming Dynasty but they came from Spain and they have been always related with Islamic culture, the same that was influential during the reign of the Chinese Emperor Zhengde (1506-1521). We can say, therefore, that in regards to Islamic symbolism, this situation of early Portuguese azulejos art was similar to that of China. At the beginning of the 16th century, the Portuguese had taken the lead in starting trade in Chinese blue-and-white porcelain. This historical fact was recorded in the Chinese and foreign literatures, and, more importantly, remains of cultural relics have been found on the ground, underground, and on the seabed. Chronologically, first there was armorial porcelain, followed by large-scale export of Kraak porcelain to Portugal, and then Chinese blue-and-white porcelain elements became clearly visible on tiles in Lisbon. According to studies conducted by Portuguese art historian Maria Miranda, there are three sources of the Portuguese blue-and-white azulejo iconography: one was introduced by the Arabs; one was imported from Spain; and another one was from the Netherlands. [1] Clearly the direct influence of Chinese blue-and-white porcelain has not been sufficiently considered. Chinese blue-and-white porcelain matured at the end of the Yuan Dynasty (1340-1368). After the development and reform in the early Ming Dynasty (14th-15th Century), it became the mainstream of Chinese porcelain after Emperor Jiajing (1522-1566) of the Ming Dynasty. It quickly spread throughout China and it started to exported in large quantities. From the 16th to the first half of the 17th century, almost all of the exported porcelain was Chinese blue-and-white porcelain. If Portuguese blue-and-white azulejos were not related to the large quantity of imported Chinese blue-and-white porcelain during this period, it is difficult to explain how blue-and-white azulejos were not so popular. After Chinese blue-and-white porcelain was exported to Portugal, blue-and-white azulejos began to become popular in Portuguese society, which clearly shows that Portuguese blue-white azulejos had a definite connection with Chinese blue-and-white porcelain. In addition, the armorial porcelain and Kraak porcelain in this period was almost entirely blue-and-white porcelain; the former due to the customization of the Portuguese; the mass production of the latter was a result of Portuguese demand and was named after the Portuguese vessel, which is enough to show that these two new varieties of blue-and-white porcelain had a direct relationship with Portugal. Third, in the 17th century, Delft in the Netherlands successfully imitated and produced blue-and-white pottery. It was also the result of

participation in the large-scale blue-and-white porcelain trade in the Netherlands, not to mention that the Portuguese began to produce blue-and-white pottery on a large scale in the early 17th century. Therefore, blue-and-white azulejos had long dominated Portugal in the late 17th and early 18th centuries, which in terms of time was closely related to the export of Chinese blue-and-white porcelain in the 16th century. Of course, in-depth research in this area has yet to be carried out. Before the end of the 17th century, Portuguese azulejos were generally polychrome, the lines were diagonal but mainly in the chequered or “*enxaquetado*” patterns that were combined with patterned tiles, covering the interior of the entire building: this period clearly showed many influences rather than simply the Islamic, also appreciated Mongol, Indian and Chinese. Since late 16th century, patterned azulejos with floral motives began to appear, gradually covering the entire walls of a building in the beginning of 17th century. Along with the prevalence of Baroque and Rococo art, a variety of rich characters began to appear on the surface of azulejos [2]. This kind of creative technique is similar to the Chinese blue-and-white porcelain production method, but the Portuguese painters incorporated the elements of light and shade and optical illusion of the western painting into the tiles of their country, which made the azulejos more rigorous, precise and true, thus producing a completely different temperament and charm. The Chinese blue-and-white porcelain is ink painting style is elegant, in contrast, the Portuguese blue-and-white tile is oil painting style on a faience canvas.

Through the research, the following conclusions are drawn:

First, the Chinese blue-and-white porcelain also plays an important role in the history of European art development. The blue-and-white porcelain crossed the sea and entered the life of the Portuguese, it has also profoundly affected the expression of Portuguese art—Azulejo, which is an important fusion point of the cultural exchange between China and Portugal. The blue-and-white porcelain moved from the Chinese mainland to the outside world, from the emergence of civilization to social fashion, indicating the beginning of globalization.

Second, the link between Portuguese blue-and-white azulejos and Chinese blue-and-white porcelain style can be divided into three stages, first, the inspiration is clearly visible; second, the style is a mixture of Chinese and Portuguese decorative elements; the last, have more Portuguese native style.

Third, azulejo is an art form developed independently in Portugal. It is a very important part of Portuguese culture and art, it also enriches the Portuguese culture and art expressions. We cannot over-exaggerate the influence of Chinese blue-and-white porcelain on Portuguese azulejos, but at the same time we must also appreciate the special role played by Chinese blue-and-white porcelain in the process of development and evolution of Portuguese azulejos.

Key-words: Chinese blue, white porcelain, Portuguese azulejos.

BIBLIOGRAPHIC REFERENCES

[1] Miranda, M. – *Portuguese Art History*. China Federation of Literary and Art Circles Publishing Corporation, Peking, 1997.

[2] Meco, J. – *Portuguese Azulejo Art*. Peking University Publishing House, Peking, 1995.

Pottery from Nishapur: Kunstwollen of Iranians

Anna Kholomeeva¹

¹ PhD student, The State Institute for Art Studies, Moscow, Russian Federation,
a.kholomeeva@gmail.com

SUMMARY

The joining of the Iranian territories to the Caliphate and the spreading of Islam had a beneficial effect on the self-consciousness of Iranian artists. The result of this was the creation of the various types of designs and aesthetic effects of pottery production in the eastern Islamic lands of the IX-XI century. According to Oleg Grabar, who was one of the major figures in the field of Islamic art, the emergence of this 'art of luxury ceramics' is one of the most uniquely early Islamic developments in art [1].

We are able to observe the variability of the principal stylistic features in Iranian pottery that are rooted in the fundamental changes under way in a certain society, its ideals, reappraisal of its values, proceeding the ideas of Alois Riegl and Hans Sedlmayr who are the bright representatives of Vienna School of Art History.

The aforementioned changes in the spirit of people came as a consequence of the Muslim conquest, and in turn led to the emergence of a variety of artistic motifs in ceramics.

This research represents a study of the glazed Iranian pottery, mainly from the city of Nishapur, through the concept of artistic will, or volition - Kunstwollen.

It will be represented through the examination of the several sources of inspiration for Iranian artists as the ways of their perception of the outside world and a subsequent transformation of the received ideas as an impelling impetus to a transformation in art.

Chinese products were one of the sources of inspiration for the Iranian artists. They transformed them and created the distinctive art types of ceramic items, revising the Far Eastern tradition in order to create something authentic, complying with the Iranian discourse.

Another source is the Arab world. Arabs, together with the graphic style of thinking, brought order to the Iranian traditionalism of artistic thinking, which was formed through a religious mode of vision with its ritual side, different from Arabic. Through the example of ceramic items with Kufic Arabic inscriptions on a creamy white opaque ceramic surface, there can also be traced the Iranian Kunstwollen. The aesthetics of Arabic calligraphy seamlessly began to grow on Iranian ground, changing over time beyond recognition. It is the transformation of these inscriptions into ornament that is a manifestation of the processes of interaction of the cultures in question.

Not only the intervening Arab ideas were transformed. The creative vision of the Iranian artists was able to transform the former images of the Iranian ethnos. A group of items depicting festive scenes, feasting, hunting, serves as an example to this.

CONCLUSION

During the examination of some ceramics types, certain principles of the internal organization of the artistic process that Nishapur's artists followed were expressed. It is also possible to describe the points of contemplation of reality, for the factors that apply to the processing of external impressions also apply to the development of works of art according to Alois Riegl.

Iranian artists were constantly in pursuit of new ideas, not content with the style once found. Through their perception of the outside world they created the new forms, artistic decisions, principles of style.

One of the important consequences of their search of artistic ideas and its subsequent embodiment was the technological development in the field of ceramics production. This is another confirmation that the creation of the piece of art is not only the consequence of technology and current materials, as Semper claimed [2]. In contrast, the approach of Riegl, based on the concept of *Kunstwollen*, which transcend the technology or the utility is confirmed by the example of Iranian ceramics.

In the case of ceramics types discussed in the preceding sections, it is important to highlight one more time the force of *Kunstwollen* search and the artistic will for artists in Nishapur. Hardly had the Iranian artists appealed to foreign form when they transformed it according to the modus of their viewing. The same process occurs with other forms from which the Nishapur's artists were seeking for inspiration.

The ceramics of the eastern lands of the IX-XII century Caliphate is also an outstanding example of a combination of the Arab and Iranian worlds' traditions. The merging of the pre-Islamic Iranian traditions with the graphic mindset of the Arabs stimulated the creation of the various types of designs and aesthetic effects of ceramic's production.

There is therefore some evidence to suggest that Iranian art in the first centuries of Islam had its own course of development based on the flexibility of culture and awareness of its own identity.

In this conjunction Grabar's general conclusion on the regional nature of the Iranian art before Mongol conquest not being "part of the newly formed Islamic art" [3] is confirmed.

The study also revealed that the process of affirming of the Iranian identity through *Kunstwollen* can be traced in Nishapur's ceramics.

Key-words: Iranian earthenware, ceramics from Nishapur, Kunstwollen Iranians', Kunstwollen, Iranian identity

¹ GRABAR O. *The visual arts*. R.N.FRYE, *The Cambridge History of Iran*. Frye R.N. (5th ed., Vol. 4, P. 352). Cambridge University Press, 2007.

² RIEGL A. *Spätromische Kunstindustrie*. Wissenschaftliche Buchgesellschaft, Darmstadt, 1973. P.8

³ GRABAR O. *The visual arts*. R.N.FRYE, *The Cambridge History of Iran*. Frye R.N. (5th ed., Vol. 4, P. 331). Cambridge University Press, 2007.

Tiles in the Museum of Civil Engineering

Alcnia Zita Sampaio¹

¹ Dep. Civil Engineering, IST, University of Lisbon, Lisbon, Portugal,
zita.sampaio@tecnico.ulisboa.pt

SUMMARY

The Museum of Civil Engineering of Instituto Superior Tcnico (IST) contains a significant collection of elements related to the different areas involved in the Construction sector. A Museum, when inserted in a technical university, is a privileged place for the preservation of the historical memory concerning the construction techniques evolution along ages, including the progress of the architectural tendencies used in urban buildings.

Concerning the Architecture topic, the Museum [1] contains the re-creation of the work room of the architect lvaro Machado (1874 - 1944), first professor of architecture of the IST, and a collection of drawings of his projects. The room recreates his atelier, originally installed in his house, in Lisbon. The work place was meticulously built by Machado, since 1910, over years of use. All the furniture was designed by him, and it is composed of desk, tripod support, bookcase and banks (Figure 1).



Figure 1 – Atelier of lvaro Machado and drawing of a project.

The architect was the author of a vast work, and following the tendency of using tiles as decorative details in buildings' facades, he applied tiles in his projects (Figure 1). According to the publication co-hosted by Caldas [2], "the quality of the drawings and the aesthetic and historic interest of the environment preserved were notable and could not immediately be dispersed" and so the IST kept "their documents and projects to be consulted and they are open to researchers to study his work".

The Museum serves as a memory of architectural work of Alvaro Machado, represented in various drawings, and contributes to the dissemination of his work revealed in several buildings in the zone of Lisbon. lvaro Augusto Machado proved early to be a young architect with great imagination, but he expressed it in a realistic mode. He was the author of several projects of single-family buildings in Lisbon (Figure 2):

- The Valmor prize was awarded in 1919 to the architect concerning a single-family project, located in Av. Duque de Loul, Lisboa. The building of the Museum Bordalo Pinheiro was built in 1913 with the architectural project of lvaro Machado, and he was awarded an honorable mention of Valmor prize of 1914;
- The building of the current Academic College, located at the Republic Avenue, was designed by him in 1904. The building of the National Society of Fine Arts (SNBA), located at Rua Barata Salgueiro, in Lisbon, was designed also by Machado.

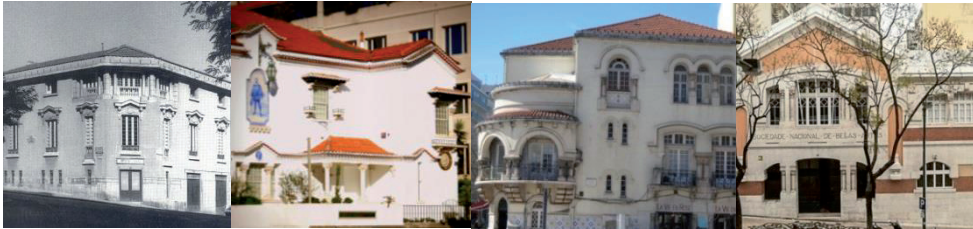


Figure 2 – Buildings projected by Machado.

The architect applied tiles on façades of urban buildings. Figure 3 presents a picture of the SNBA building and a drawing of the architectural project and a pencil drawings, ink and watercolor on paper of the architectural project of the House of Health Portugal-Brazil in Lisbon. Both show tiles applied in facades.

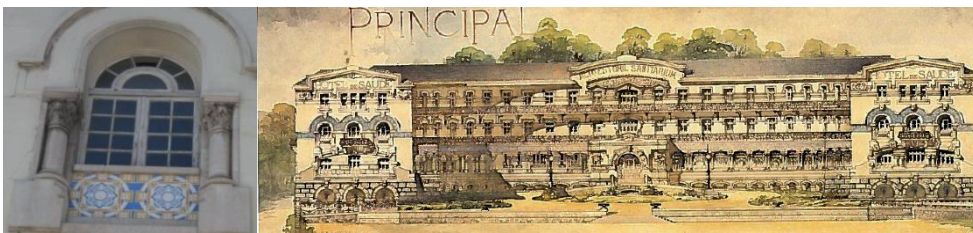


Figure 3 – Tiles applied in facades.

The architectural drawings outlined by the architect Álvaro Machado are part of the estate given to IST. The drawings show the application of tiles on facades, and how each ceramic element is represented in detail using watercolor. The quality and aesthetic of the drawings are evident supporting the great interest of IST to preserve these notable graphic works made by Machado and so it could not be dispersed.

Key-words: Tiles, heritage, atelier of architect, projects, drawings

BIBLIOGRAPHIC REFERENCES

¹ *Museum of Civil Engineering*, <http://museudec.tecnico.ulisboa.pt/>

² CALDAS, João, PERA, Teresa - *Álvaro Machado, first professor of Architecture at the IST - exhibition of the donated estate*. Museum of Civil Engineering, IST, Lisbon, 2002.

The use of “Tijomel” tiles in Portuguese modern architecture

Catarina F. M. Geraldes¹, João Manuel Mimoso² and Alexandre Pais³

¹ *Departamento de Conservação e Restauro, Faculdade de Ciências e Tecnologia, Universidade NOVA de Lisboa, Caparica, Portugal; Laboratório Nacional de Engenharia Civil (LNEC), Lisboa, Portugal; cgeraldes@lnec.pt*

² *Laboratório Nacional de Engenharia Civil (LNEC), Lisboa, Portugal*

³ *Museu Nacional do Azulejo, Lisboa, Portugal*

SUMMARY

The tile (*azulejo*) is a traditional art in Portugal, much more than an object, thus encompassing a wealth of shapes and dimensions. Several books [1-5] present and discuss the use of *azulejos* in Portuguese modern architecture. However, these tend to ignore the use of other glazed ceramics of uncertain classification in the same context. Through the process of identification of modern *azulejos* in Portuguese cities, a new type of glazed ceramic coating has been found which may arguably be classified as *azulejos* [6]. These are mosaics with a module of 20 x 40 mm whose units are flat glazed ceramics. The only difference from what we usually understand as *azulejos* result from the facial dimensions (ca. 18 x 38 mm) of those *tesselae*. They were manufactured at Ourém, Portugal, by a company named Tijomel from 1960 to 1980 and are a unique product that was widely used at the street level as well as in certain details of modern buildings, such as columns or entrance doors.

Tijomel mosaics were often used with great creativity and quite striking results (figure 1). The authors believe that this type of coating is worth considering as part of the modern heritage in Portuguese architecture and decoration, and present and discuss for the first time the use of the Tijomel mosaics, revealing several examples of use.

Apart from a slight reference to these mosaics found in the website of *Cerâmica modernista em Portugal* [7], there are no studies regarding these “azulejos” nor known references to them in the published bibliography. The importance of bringing to light their integration is related to the will to create potential interest for their preservation as cultural heritage worth of care.

Several Portuguese cities such as Lisbon, Porto, Torres Vedras and others were visited allowing the identification of many interesting, previously unknown examples, which denote a clear artistic intention in their integration since the colours, patterns and areas lined, create a diverse and often striking impression. All cases included are considered from the point of view of a street walker, therefore excluding the more utilitarian use in interiors. It was possible to identify, so far, 78 examples considered worth mentioning, most of which in Porto and Lisbon, 35 and 19 cases respectively. Those who studied modern *azulejos* do not seem to be aware of their existence and the knowledge about them is scarce or non-extant. Some cases already present degradation, pointing to the need for preservation actions of this heritage, not only for their distinctiveness but also for the way they complement the modernity of the constructions. Therefore, calling to attention their existence and relevance as a heritage asset, as well as their study and conservation are essential.

In this way, further investigations need to be carried out. The identification of more Tijomel mosaics integration in Portuguese cities, in order to gather a higher number of examples as possible; understand the relation between the factory and the artists who developed their works there and, the study of the factory production is particularly important. Such study will reflect

on the knowledge of the characteristics of these *azulejos*, to later on be able to understand which intervention methods are the most appropriate.



Figure 1 – Avenida do Lago N° 61, Estoril

Key-words: Azulejos / Tijomel / Modern architecture / Portugal

ACKNOWLEDGMENTS

The authors acknowledge the Portuguese Science Foundation (FCT) for the funding of PhD grant PD/BD/114408/2016 (Catarina Gerales) and Project FCT-AzuRe - Estudos no Azulejo Português para Candidatura a Património da Humanidade (PTDC/EPH-PAT/5096/2014) supporting this research.

BIBLIOGRAPHIC REFERENCES

- [1] BURLAMAQUI, Suraya - *Cerâmica Mural Portuguesa Contemporânea, Azulejos, Placas e relevos*. ISBN 972-564-270-8, Editor Quetzal, Lisboa, 1996
- [2] SAPORITI, Teresa - *Azulejos Portugueses, padrões do século XX*. No. of edition ISBN 972-97653-1-6, Editor Publilimpresores, Artes Gráficas LDA., Lisboa, 1998
- [3] CALADO, Rafael Salinas et al. - *O Revestimento Cerâmico na Arquitectura em Portugal*. No. of edition ISBN 972-8095-45-7, Editor Estar, Lda, Lisboa, 1998
- [4] HENRIQUES, Paulo et al. - *O Azulejo em Portugal no século XX*. No. of edition ISBN 972.787.009.0, Editor Inapa, Lisboa, 2000
- [5] NERY, Eduardo - *Apreciação Estética do Azulejo*. No. of edition ISBN 978-972-797-150-3, Editor Inapa, Lisboa, 2007
- [6] [online] *O que é o Azulejo?* <https://blogazlab.wordpress.com/2017/12/15/o-que-e-o-azulejo-3/>, 2017 [Accessed 20 May 2018]
- [7] [online] *Casa de Igrejas Caeiro | "Teatro" de Maria Keil*. Cerâmica modernista em Portugal: <http://ceramicamodernistaempportugal.blogspot.com/search?q=Tijomel/> [Accessed 20 May 2018]

Technical identification of the earliest productions of faience tiles in Lisbon

João Manuel Mimoso¹, Maria Augusta Antunes¹, Silvia Pereira¹, Maria de Lurdes Esteves², Ana Margarida Cardoso³, António Candeias³ and Alexandre Pais²

¹ *Laboratório Nacional de Engenharia Civil, jmimoso@lnec.pt*

² *Museu Nacional do Azulejo*

³ *Laboratório HERCULES- Universidade de Évora*

SUMMARY

For one year since July 2017, the *Museu Nacional do Azulejo* (MNAz- Portuguese National Azulejo Museum), the *Laboratório Nacional de Engenharia Civil* (LNEC) and the HERCULES Laboratory of the University of Evora made a joint effort in the instrumental study of 16th century faience azulejos, aimed at identifying those of Portuguese origin based on their composition and the technology used and thus establish on firmer ground the origins of the production of faience azulejos in Lisbon.

Azulejo panels, loose tiles and fragments were collected by removing small fractions of the glaze (circa 1-3 mm³) with biscuit attached. Samples were as follows: seven samples of Hispano-Moresque azulejos from the collections of the MNAz and archeological excavations, believed to have been produced in Seville and expected to date from the first to the third quarters of the 16th century; five faience samples from Seville (four dated 1570-1596 and one presumed from the 17th century); and 20 samples from loose tiles or panels known or now attributed to the workshops of Lisbon from the 1560s to the 17th century.

The samples were stabilized in resin, cut to obtain a flat section and polished for observation and analysis by scanning-electron microscopy coupled with energy-dispersive spectrometry (SEM-EDS). SEM-EDS observations and analyses were made at the HERCULES Laboratory in Évora using a HITACHI 3700N SEM coupled to a BRUKER XFlash 5010 EDS. The specimens were uncoated and the observations were made in back-scattering mode (BSE) with air in the chamber at a pressure of 40Pa and at an accelerating voltage of 20.0 kV. The acquisition of spectra was done in the same conditions with the detector set at ca. 8 mm distance from the surface of the specimens.

All EDS spectra were acquired according to the recommendations given in [1] and saved in XY-ASCII format (*spx* file extension). They were processed by opening with the Artax™ spectral analysis PC software as used with the Bruker Tracer III and other XRF analysers of the same brand, and saved as spectral graphs.

Given the time for presentation, this communication will focus on only two sorts of information gathered: the morphology of the glazes and interfaces, which are related to the firing parameters, and the results of the EDS analysis of the glazes. This information will be shown to be sufficient to separate the productions in four distinct groups: Seville Hispano Moresque; Lisbon 16th century; Seville majolica (last quarter of the 16th century), Lisbon 17th century (possibly including late 16th century productions).

As an example, figure 1 compares the most relevant part of the compositional spectra (cut due to space restrictions), the glaze composition in major elements except Sn (which was excluded because the quantification varied too much in a single specimen with the chosen area due to local concentrations of tin oxide crystals) and sections of azulejos from two of the groups mentioned, depicting clear differences in what pertains to the Na-Mg-Al relative contents as well as to the glaze inclusions.

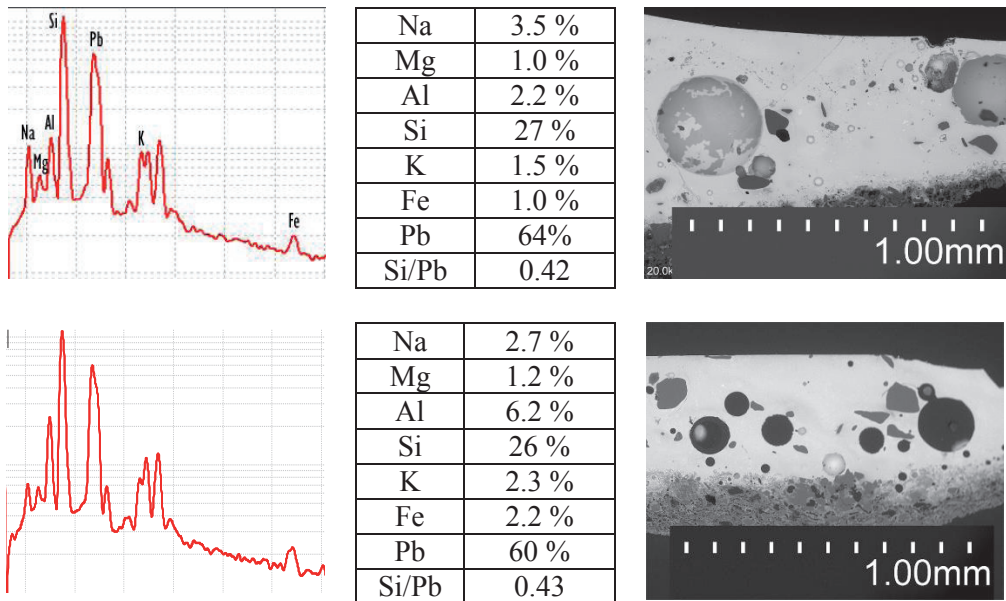


Figure 1 – Top: Az065 Hispano-Moresque tile presumably from the workshops of Seville; bottom Az013/03 ample from the renaissance panel signed “João de Góis” at Igreja da Graça in Lisbon.

Left to right: abridged EDS spectrum of the glaze between 0.6 and 7 keV; EDS quantification in weight of seven glaze elements corrected to 100% and Si/Pb ratio; image of a section of the glaze.

ACKNOWLEDGEMENTS

Communication produced as an outcome of Project FCT-AzuRe - Estudos no Azulejo Português para Candidatura a Património da Humanidade (PTDC/EPH-PAT/5096/2014) funded by FCT, the Portuguese Foundation for Science and Technology. S. Pereira acknowledges FCT for her Post-Doc Grant (SFRH/BPD/116807/2016).

BIBLIOGRAPHIC REFERENCE

1. MIMOSO, J. et al. – *On the use of glaze and biscuit X-ray spectra in heritage azulejos as beacons of provenance*, in Proc. GlazeArt 2018, LNEC, Lisbon 29-30 Oct.2018.

Analytical study of the azulejos from Igreja da Graça in Lisbon, signed by João de Góis

João Manuel Mimoso¹, Alexandre Pais², Maria de Lurdes Esteves², Miguel Ângelo Silva³, Ana Margarida Cardoso³, Maria Augusta Antunes¹, Silvia R. M. Pereira^{1,4} and António Candeias⁴

¹ *Laboratório Nacional de Engenharia Civil, Lisbon, Portugal, jmimoso@lnec.pt*

² *Museu Nacional do Azulejo, Lisbon, Portugal, apais@mnazulejo.dgpc.pt;*

³ *Igreja da Graça, Lisboa, Portugal*

⁴ *Laboratório HERCULES- Universidade de Évora, Évora, Portugal*

SUMMARY

Besides the famous panels of Capela de São Roque in Lisbon, signed and dated by the painter, the incomplete and dispersed panels of Igreja da Graça are the only other Renaissance azulejos produced and remaining in Lisbon that are known to be fully signed. The panels have now been studied through twelve different small samples collected from as many azulejo units. This communication reports the results of that study identifying the main micro-morphological features and the variations that may be ascribed to different chronologies or to different workshops. The tiles making up the figure bearing the signing monogram have been studied in detail by scanning-electron microscopy coupled with energy-dispersive spectrometry (SEM-EDS) to establish a morphological and analytical template aimed at identifying a common officinal provenance in azulejos of the same general chronology known or presumed to have been produced in Lisbon.

On the walls of the ante-sacristy of Igreja da Graça in Lisbon subsist parts of one or more azulejo panels decorated with grotesque motifs that suggest an early chronology – figure 1. The incomplete panels have been reported by other authors [e.g. 1] and ascribed to the 2nd half of the 16th century based on the decoration. They were also often assumed to be of Portuguese production, although that assumption was not objectively proved. The rather surprising technical quality of most individual tiles or their variability, e.g. in terms of colour continuity, passed unmentioned and actually no author considered the tiles sufficiently important to justify a detailed observation.

In December 2014 we obtained an authorization from the church to make an exploratory inspection of the tiles and an acquisition of X-ray fluorescence (XRF) spectra using a Bruker Tracer III SD portable unit. We also made a detailed acquisition of images the painted monogram of the workshop master (and presumably also one of the painters of the original panels) was found [2]. That monogram (figure 2) has now been conclusively identified [3] as that of the elusive João de Góis, a Flemish faience and tile manufacturer until now known only from an Inquisition process for heresy of 1561/62 [4] and a tally of professionals living in Lisbon, made in 1565 for taxation purposes [5]. From the images acquired a first graphical restitution of the panel remains was attempted resorting to digital technology and the dispersed tiles started being assembled into what may have been a panel once bearing a shield of arms together with smaller panels and pilasters (for some images of the restitution see [2]).

SEM-EDS observations and analyses were made at the HERCULES Laboratory in Évora using a HITACHI 3700N SEM coupled to a BRUKER XFlash 5010 EDS. The results have shown that the tiles were fired in a cycle including a very long firing/cooling period, maybe using a single kiln for tin-glazed pottery then extant in Lisbon, resulting in a characteristically over-developed interface with extensive growth of lead-rich K-feldspars (figure 3) already found by other authors

in reproduction studies [6]. This is a fortunate instance because it offers a readily recognizable sine-qua-non characteristic for tiles produced within the same technological parameters. A study of the biscuits, which are the only part of the tiles believed to be wholly produced with local materials, identified three different types correlated with macroscopic differences in the painting and possibly related with phases of the production of the individual tiles. An explanation for this integration of tiles produced in different periods depends on a study of the backside markings of the ceramic bodies, which can only be made when the tiles will be removed from the walls for remounting in their correct positions.

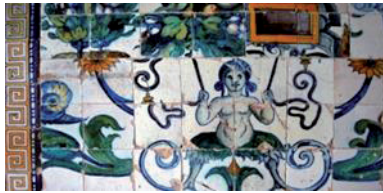


Figure 1 – An aspect of the dispersed grotesque azulejo panels in Igreja da Graça

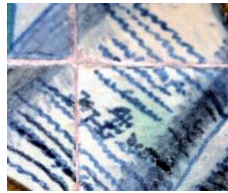


Figure 2 – Monogram of João de Góis signing the panels

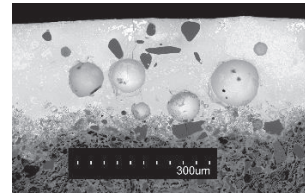


Figure 3 – The glaze and glaze-biscuit interface of sample Az013/L2

Key-words: Renaissance majolica; Azulejo, Igreja da Graça in Lisbon; João de Góis; instrumental characterization

ACKNOWLEDGEMENTS

Communication produced as an outcome of Project **FCT-AzuRe** - Estudos no Azulejo Português para Candidatura a Património da Humanidade (PTDC/EPH-PAT/5096/2014) funded by **FCT**, the Portuguese Foundation for Science and Technology. LNEC Research Project 0202/111/19747. S. Pereira acknowledges FCT for her Post-Doc Grant (SFRH/BPD/116807/2016).

BIBLIOGRAPHIC REFERENCES

- ¹ SANTOS SIMÕES, J.M. - *Azulejaria em Portugal nos séculos XV e XVI*. 2ª edição. Fundação Calouste Gulbenkian, Lisboa, 1990, pps. 108-109.
- ² PAIS, A. et al. – *Graça Church Revisited* in Proc. Int. Conf. Glazed Ceramics in Cultural Heritage (GlazeArch2015), LNEC, Lisbon.
- ³ PAIS, A. et al. – *João and Filipe de Góis in Lisbon- documental testimonies* in Proc. Int. Conf. Glazed Ceramics in Cultural Heritage (GlazeArt2018), LNEC, Lisbon.
- ⁴ ARCH. TORRE DO TOMBO, *Processo de João de Góis* (29/07/1561 - 08/02/1562), proc. 6820. Tribunal do Santo Ofício, Inquisição de Lisboa, processos (1536-1821), (1561/1562).
- ⁵ LISBON TOWN HALL, *Livro do lançamento e serviço que a Cidade de Lisboa fez a el' Rei Nosso Senhor no ano de 1565: documentos para a história da cidade de Lisboa*. Volume II, Câmara Municipal de Lisboa, Lisboa, 1947, pp. 267.
- ⁶ MOLERA, J. et al. - *Interactions between Clay Bodies and Lead Glazes*, Journal of the American Ceramic Society, May2001, Vol. 84, Nr 5, pps. 1120-1128.

The 16th century nativity azulejo panel called “de Nossa Senhora da Vida”

Alexandre Pais¹, Maria Antónia Pinto de Matos¹, João Manuel Mimoso², Maria de Lurdes Esteves¹, Ana Margarida Cardoso³ and António Candeias³

¹ *Museu Nacional do Azulejo, Lisbon, Portugal, apais@mnaz.dgpc.pt,*

² *Laboratório Nacional de Engenharia Civil, Lisbon, Portugal*

³ *Laboratório HERCULES, Universidade de Évora, Évora, Portugal*

SUMMARY

Among the first known references to *azulejos* from the 16th century integrated in Portuguese architecture is the so-called panel of *Nossa Senhora da Vida* (“Our Lady of Life”), belonging to a chapel of the demolished *Igreja de Santo André*, near the *Convento da Graça*. These *azulejos* were already labelled in the important work *Santuário Mariano* (1707), a collection of books by Fr. Agostinho de Santa Maria (1642-1728) who aimed to describe all the churches and chapels dedicated to the Virgin Mary in Portugal and its overseas territories. Among the hundreds of representations labelled in this extensive work there are only a few descriptions of *azulejo* panels, one of which precisely *Nossa Senhora da Vida* [1], which is a testimony of how impressive it still was at time when it was already outmoded.

The *azulejos* were considered matchless in Lisbon, and they represent in *trompe l’oeil* a huge stone retable with two niches for the statues of the Evangelists who describe the Birth of Jesus (Mathew and John). In the centre there is a representation of the Nativity with shepherds and above an image reminding half of a *Della Robbia* tondo with the Annunciation, having in the middle an opening where a window once was.

Igreja de Santo André had a gothic architecture with a top main chapel and four small side chapels. One of the chapels on the south side was dedicated to Our Lady of Life and the panel was part of its interior lining. The panel was removed circa 1845 when it was decided to demolish the church. Eighteen years afterwards the panel went to the National Library where it was exposed in 1872. After an adventurous pilgrimage it was sent in 1969 to the deposit created in the Madre de Deus convent and are today one of the prize jewels of the *Museu Nacional do Azulejo* installed there[2].

This communication reviews the oldest known written sources on the panel and presents the results of the first instrumental study done on the *azulejos* of one of the most important testimonies of a technological continuity respecting the first decades of the production of majolica tiles in Portugal.

Five small samples were collected from the panel, stabilized in resin and polished for observation and analysis by scanning-electron microscopy coupled with energy-dispersive spectrometry (SEM-EDS). SEM-EDS observations and analyses were made at the HERCULES Laboratory in Évora using a HITACHI 3700N SEM coupled to a BRUKER XFlash 5010 EDS. Figure 2 depicts a back-scattered image of a section of one of the samples, showing both the glaze and its interface with the biscuit.



Figure 1 – The center part of the panel entitled Nossa Senhora da Vida.

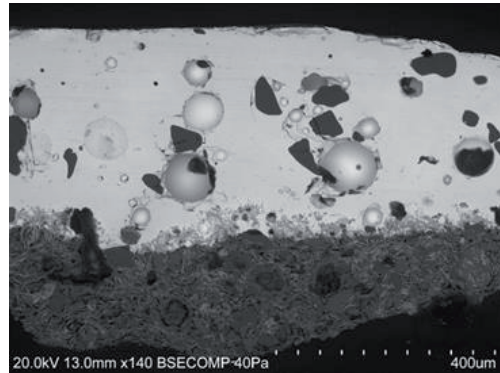


Figure 2 – Backscattered SEM image of the glaze and glaze-biscuit interface of sample Az032/01 taken from one of the tiles of the Nossa Senhora da Vida panel.

Both the microscopic morphology and the composition of the glaze are consistent with an origin within the technological circle of the workshop of João de Góis [3]. However, the red biscuits have a slightly different composition. The hypothesis of a production by the workshops of Lisbon is difficult to dispute given the morphological and compositional similitudes with the productions of João de Góis. We are now studying the local sources of marl which was the raw material for the biscuits to gather data on its origin in support of a better-founded opinion.

Key-words: Renaissance majolica; Azulejo panel Nossa Senhora da Vida; João de Góis; Instrumental study of majolica; Museu Nacional do Azulejo

ACKNOWLEDGEMENTS

Communication produced as an outcome of Project **FCT-AzuRe** - Estudos no Azulejo Português para Candidatura a Património da Humanidade (PTDC/EPH-PAT/5096/2014) funded by **FCT**, the Portuguese Foundation for Science and Technology.

LNEC Research Project 0202/111/19747.

BIBLIOGRAPHIC REFERENCES

- ¹ SANTA MARIA, Agostinho de - *Santuário Mariano, e História das Imagens milagrosas de Nossa Senhora*, Lisboa, Officina de Antonio Pedrozo Galram, 1721, Tomo VII, p. 71-75
- ² GUIMARÃES, Ribeiro - *SUMMARIO DE VARIA HISTORIA. Narrativas, lendas, biographias, descrições de templos e monumentos, estatísticas, costumes civis, políticos e religiosos de outras eras. Por...* Rolland & Semiond, Lisboa, 1872, pps. 103-111.
- ³ PAIS, A. et al. – *Graça Church Revisited* in Proc. Int. Conf. Glazed Ceramics in Cultural Heritage (GlazeArch2015), LNEC, Lisbon.

The lost azulejo panel of the Church of Santo André, near Graça, in Lisbon

Alexandre Pais¹, Victor Filipe², João Manuel Mimoso³, Maria de Lurdes Esteves¹, Maria José Sequeira⁴ and Ana Margarida Cardoso⁵

¹ *Museu Nacional do Azulejo, Lisbon, Portugal, apais@mnaz.dgpc.pt,*

² *Uniarq - Centro de Arqueologia da Universidade de Lisboa, Portugal*

³ *Laboratório Nacional de Engenharia Civil, Lisbon, Portugal*

⁴ *Direção-Geral do Património Cultural, Departamento dos Bens Culturais, Portugal*

⁵ *Laboratório HERCULES, Universidade de Évora, Évora, Portugal*

SUMMARY

The so called *Painel de Nossa Senhora da Vida* (Panel of Our Lady of Life), once situated in a chapel in the now demolished *Igreja de Santo André* (Saint Andrew) near the *Igreja da Graça* in Lisbon, numbers among the earliest known references to azulejos from the 16th century in Portuguese architecture. The church had a main chapel and four small side chapels. One of the two on the south side was dedicated to *Our Lady of Life*. The azulejo panel of the chapel of *Our Lady of Life* was removed circa 1845 when it was decided to demolish the church, while a second panel located in front was abandoned due to a lack of resources to remove and preserve both.

During the current year (2018) an archaeological excavation discovered elements of the demolished Church of Saint Andrew among which were five fragments of figurative majolica azulejos, maybe remains of the lost panel.

This article describes the newly found fragments and discusses the analytical results of a study made on them, comparing them to the *Igreja da Graça* azulejos by João de Góis.

Of royal patronage, the gothic *Igreja de Santo André* was built between 1334 and 1340 by Ayres Martins and his wife Maria Esteves after a land donation by the king and queen of Portugal. The church had a main chapel and four small side chapels. The two chapels on the south side were dedicated to *Santo Ambrósio* and *Nossa Senhora da Vida* (Our Lady of Life), while on the north side to *Nossa Senhora da Conceição* and to the *Almas* (All Souls), this added during the reign of king *João V* (after 1712). The azulejo panel of the chapel of *Nossa Senhora da Vida* was removed circa 1845 when it was decided to demolish the church, and it can now be admired at the *Museu Nacional do Azulejo*.

The man who acted to save the *Nossa Senhora da Vida* panel before the demolition, left a note stating that there was a second panel in front. He also mentioned a cartouche in the chapel bearing the date “1580” but, being able to conserve only one, he abandoned the one that he considered to be of a lesser value [1].

During an archaeological excavation held during 2018 at a building in *Travessa do Açougue*, where it is still possible to see the remains of the main chapel of the former church, other elements of the building were discovered including part of a ceramic floor and five fragments of majolica azulejos, seemingly from a historiated panel. Three of the fragments are illustrated in figure 1. A hypothesis is that these fragments are remainders of the other, now lost, azulejo panel known to have existed in the same church.

The three fragments illustrated in figure 1 were sampled and the samples embedded in resin before polishing for observation and analysis by scanning-electron microscopy coupled with energy-dispersive spectrometry (SEM-EDS). The SEM-EDS observations and analyses were made at the HERCULES Laboratory in Évora using a HITACHI 3700N SEM coupled to a

BRUKER XFlash 5010 EDS. Figure 2 depicts a back-scattered image of a section of one of the samples, showing both the glaze and its interface with the biscuit.



Figure 1 a, b, c (left to right) – Azulejo fragments found during an archaeological prospection in the grounds of the demolished Igreja de Santo André, from which samples Az331/02, Az331/03 and Az331/05 were taken

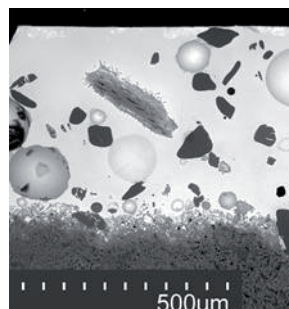


Figure 2 – Backscattered SEM image of the glaze and glaze-biscuit interface of sample Az331/02

The microscopic morphology and the composition of both glazes and biscuits are consistent between samples, strongly suggesting that all were indeed once part of the same panel. The interface outgrowth of neoformed crystals seen in figure 2 also suggests that the tiles were fired in a cycle including a very long cooling period [2]. A comparison with a similar image from a section of one of the azulejos from the panels at Igreja da Graça signed by João de Góis [3] shows a very similar morphology, both of the inclusions and of the interface. That similitude may well derive from the fact that both were produced within the same technological circle, however the composition of the biscuits is considerably different and at this moment we cannot even assert whether the panel from which these fragments stem was manufactured in Lisbon.

Key-words: Renaissance majolica; Portuguese azulejos; Santo André church in Lisbon

ACKNOWLEDGEMENTS

Communication produced as an outcome of Project **FCT-AzuRe** - Estudos no Azulejo Português para Candidatura a Património da Humanidade (PTDC/EPH-PAT/5096/2014) funded by **FCT**, the Portuguese Foundation for Science and Technology. LNEC Research Project 0202/111/19747.

BIBLIOGRAPHIC REFERENCES

- ¹ GUIMARÃES, Ribeiro - *SUMMARIO DE VARIA HISTORIA. Narrativas, lendas, biographias, descrições de templos e monumentos, estatísticas, costumes civis, políticos e religiosos de outras eras*, Rolland & Semiond, Lisboa, 1872, pps. 103-111.
- ² MIMOSO, J-M. et al. – *Multi-analytical study of the azulejos from Igreja da Graça in Lisbon, signed by João de Góis*, in Proc. Int. Conf. Glazed Ceramics in Cultural Heritage (GlazeArt2018), LNEC, Lisbon.
- ³ MOLERA, J. et al. - *Interactions between Clay Bodies and Lead Glazes*, Journal of the American Ceramic Society, May 2001, Vol. 84, Nr 5, pps. 1120-1128.

The azulejos in the *Capela de São Roque* in Lisbon

Alexandre Pais¹, Teresa Morna², João Miguel Simões², João Manuel Mimoso³, Maria de Lurdes Esteves¹, Ana Margarida Cardoso⁴, Silvia R. M. Pereira³, António Candeias⁴

¹ *Museu Nacional do Azulejo, Lisbon, Portugal, apais@mnaz.dgpc.pt,*

² *Museu de São Roque, Lisbon, Portugal*

³ *Laboratório Nacional de Engenharia Civil, Lisbon, Portugal*

⁴ *Laboratório HERCULES, Universidade de Évora, Évora, Portugal*

SUMMARY

The azulejos in the *Capela de São Roque* (Saint Roch Chapel) in the church of the same saint, in Lisbon, are justly considered one of the major majolica works made anywhere during the last quarter of the 16th century [1]. The earliest known surviving ensemble of Portuguese manufacture signed and dated, (“Francisco de Matos / 1584”) has long puzzled art historians mostly because their magnificence seems to have sprouted literally by spontaneous generation with no predecessors and few immediate successors.

The set may be considered composed of four panels: two lower panels, facing each other, have the attributes of the saint painted on them. One of these, on the Gospel side of the chapel, depicts the dog with the loaf in its mouth (the “Panel of the Dog”) and bears the date and signature (figure 1). Although the design is noticeably different, technically the facing panel is a mirror image of the first. However, as we look up, the panel is not interrupted and continues up to the ceiling depicting a scene of the miracle of the bishop (the “Panel of the Bishop”). There is a clear boundary marked by the tints of yellow and of the blue showing that the upper panel was produced at a different time and very likely painted by a different hand (figure 2). Side by side with this panel, over a door, is the fourth panel depicting two winged children looking back to the chapel (the “Panel of the Cherubs”).



Figure 1 – The signed panel on the Gospel side of Capela de São Roque



Figure 2 – A partial view of the panels on the Epistle side of Capela de São Roque

At the insistence of José Queirós, a noted artist and historian of Portuguese ceramics, a large painting that covered both the bishop and the cherubs panels was removed in 1913 and the upper side of the lining was thus discovered [2]. Queirós reports that the panels were damaged because of the careless perforations needed to support the painting and a restoration of all the panels was entrusted to António Luiz de Jesus, an aged third-generation master painter. Queirós reports that

all fragments of the cut and perforated tiles were conserved but yet 47 reproduction tiles had to be made plus a number of fragments and that although the blue and violet were satisfactorily reproduced, the yellow and green did not match the original [2].

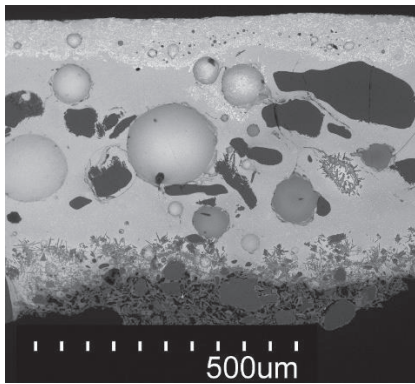


Figure 3 – The glaze and glaze-biscuit interface of a yellow tile of the Panel of the dog (sample Az068/02)

SEM-EDS observations and analyses were made at the HERCULES Laboratory in Évora using a HITACHI 3700N SEM coupled to a BRUKER XFlash 5010 EDS. The microscopic SEM analysis has shown that the composition and the morphology of the glazes and the glaze-biscuit interfaces (figure 3) are remarkably similar to the tiles of João de Góis in Igreja da Graça (see [3]) showing that technologically the linings of Capela de São Roque are not an isolated oddity.

Unexpectedly, samples from the several panels do not depict clear morphological differences suggesting that the panels of the bishop and of the cherubs were not manufactured much later than the lower panels. The reproduction tiles are clearly identifiable by their glaze-biscuit interface with only minor crystalline growth. However, their composition is uncannily similar to that of the original tiles, testifying to the knowledge of the restorer who did not use any “modern” materials then available.

This communication reviews José Queirós’ references to the panels made over a century ago, when a part of the lining was uncovered, and his information is compared with the objective proofs gained from instrumental results. The results also point to a definite technological ancestry.

Key-words: Renaissance majolica; Portuguese azulejos; Francisco de Matos; João de Góis; São Roque church in Lisbon

ACKNOWLEDGEMENTS

Communication produced as an outcome of Project **FCT-AzuRe** - Estudos no Azulejo Português para Candidatura a Património da Humanidade (PTDC/EPH-PAT/5096/2014) funded by **FCT**, the Portuguese Foundation for Science and Technology. S. Pereira acknowledges FCT for her Post-Doc Grant (SFRH/BPD/116807/2016).

LNEC Research Project 0202/111/19747.

BIBLIOGRAPHIC REFERENCES

- ¹ MECO, J. – *O azulejo em Portugal*. Publicações ALFA, Lisboa 1993 pp. 195.
- ² QUEIRÓS, J. – *Olarias do Monte Sinay*. Typographia Castro Irmãos, Lisboa 1913 pps 15-18; 103-115.
- ³ MIMOSO, J-M. et al. – *Analytical study of the azulejos from Igreja da Graça in Lisbon, signed by João de Góis*, in Proc. Int. Conf. Glazed Ceramics in Cultural Heritage (GlazeArt2018), LNEC, Lisbon.

An unknown jigsaw in the Cathedral of Setúbal

Alexandre Pais¹, Pe. Rui Rosmaninho², João Manuel Mimoso³, Maria de Lurdes Esteves¹ and Ana Margarida Cardoso⁴

¹ Museu Nacional do Azulejo, Lisbon, Portugal, apais@mnaz.dgpc.pt

² Sé de Setúbal, Setúbal, Portugal

³ Laboratório Nacional de Engenharia Civil, Lisbon, Portugal

⁴ Laboratório HERCULES, Universidade de Évora, Portugal

SUMMARY

Recently, Father Rui Rosmaninho of the *Sé de Setúbal* (Cathedral of Setubal) contacted the Museu Nacional do Azulejo because of some azulejos extant there. Eventually he also mentioned a curious application of odd azulejos lining a hidden wall. Secluded by the altar, was a series of 16th century renaissance azulejos with images in white with blue contours over a yellow background (figure 1). The azulejos were probably once part of a chapel lining that was removed and some were re-applied here at an unknown time. Their origin and purpose remain mysterious. The tiles were applied without any concern for continuity and it was necessary to photograph them individually to then digitally reassemble this jigsaw and reveal the hidden images. Now it is possible to identify flowers and fruits, probably related to two cornucopias, but the most surprising elements are two feminine winged figures. Both have crowns, although of different sorts, one is a young lady with butterfly wings (figure 2) and the other is an elderly woman with bird wings. In spite of our efforts it is very difficult to combine the azulejos because of the extensive floral elements, and only after their removal and through the biscuit markings will it be possible to perceive the number and dimensions of the panels and gain a better insight of the motifs.



Figure 1 – The renaissance puzzle as it was found in the Cathedral of Setubal



Figure 2 – Partial reconstruction of the butterfly-winged Young Lady

The painting of motives in white with blue contours against a yellow background can also be seen in the *Capela de São Roque* (St. Roch Chapel) in Lisbon [1] but there are important differences between the two sets. The Setúbal series is amateurish, compared to its Lisbon counterpart: the hand of the painter was not particularly sure; the blue colours ran over firing, resulting in drips that tarnish the composition, and the yellow pigment covered the white glaze unevenly. However, these aspects do not diminish the importance of the find. On the contrary, they seem to point to an early effort that may place these panels among the earliest examples of

the production of majolica azulejos in Portugal. An alternative but also compelling possibility is that they were produced by a new workshop aiming to compete in the field with established producers, but whose technology was not yet sufficiently evolved.

Five azulejos were sampled and test items produced for observation and analysis by scanning-electron microscopy coupled with energy-dispersive spectrometry (SEM-EDS). SEM-EDS observations and analyses were made at the HERCULES Laboratory in Évora using a HITACHI 3700N SEM coupled to a BRUKER XFlash 5010 EDS.

The observations and analyses have shown that there are two different types of azulejos in the Setubal panels. Although the compositions of the glazes are similar, the biscuits are very different in their calcium content. The morphology of the glazes and of the interfaces are also quite different although both suggest a firing cycle involving a long cooling period [2]. It is not known at this time whether each type corresponds to a different panel, or whether one of the types corresponds to a loose number of azulejos produced at a later time to replace missing or decayed original tiles. This can however be ascertained when all the tiles are removed and individually classified in each of the two types.

Considering all characteristics together, however, and comparing them with the panels at Igreja da Graça [3] there can be little doubt that the tiles are of Portuguese production and can be ascribed to the technological circle of the workshop of João de Góis.

This communication will present a partial restitution of the figures, report some results of the first study made of the azulejos with instrumental support and discusses their technological placement towards other examples of known origin.

Key-words: Renaissance majolica; Portuguese azulejos; Francisco de Matos; Sé de Setúbal; Igreja de Santa Maria de Setúbal.

ACKNOWLEDGEMENTS

Communication produced as an outcome of Project **FCT-AzuRe** - Estudos no Azulejo Português para Candidatura a Património da Humanidade (PTDC/EPH-PAT/5096/2014) funded by **FCT**, the Portuguese Foundation for Science and Technology. LNEC Research Project 0202/111/19747.

BIBLIOGRAPHIC REFERENCES

- ¹ SANTOS SIMÕES, J.M. - *Azulejaria em Portugal nos séculos XV e XVI*. 2ª edição. Fundação Calouste Gulbenkian, Lisboa, 1990, pps. 108-109.
- ² MOLERA, J. et al. - *Interactions between Clay Bodies and Lead Glazes*, Journal of the American Ceramic Society, May2001, Vol. 84, Nr 5, pps. 1120-1128.
- ³ MIMOSO, J-M. et al. – *Multi-analytical study of the azulejos from Igreja da Graça in Lisbon, signed by João de Góis*, in Proc. Int. Conf. Glazed Ceramics in Cultural Heritage (GlazeArt2018), LNEC, Lisbon.

Degradation of Egyptian faience shabti produced with exterior glazing methods

Corinna de Regt¹, Luc Megens² and Mandy Slager³

¹Post-master conservator-in-training at University of Amsterdam (UvA), Amsterdam, the Netherlands, c.w.deregt@uva.nl

²Heritage scientist at Cultural Heritage Agency of the Netherlands (RCE), Amsterdam, the Netherlands, l.megens@cultureelerfgoed.nl

³Lecturer and coordinator MA and post-MA program conservation of glass and ceramics at University of Amsterdam (UvA), Amsterdam, the Netherlands, M.Slager@uva.nl

SUMMARY

Egyptian faience is a glazed material composed mainly of silica, with the addition of small amounts of natron or plant ash, lime and metal oxides. It was first developed in Egypt in Predynastic times. The manufacture of Egyptian faience ‘shabti’ funerary figurines, who served to answer to the tasks the deceased would be asked to carry out in the afterlife, took place from the Middle Kingdom (2040 – 1782 BC) until the Ptolemaic period.

VULNERABILITY OF EGYPTIAN FAIENCE

In 2017, research was carried out on a group of eleven Egyptian faience shabti from the Dutch National Museum of Antiquities (RMO) in Leiden, the Netherlands, which displayed unexpected degradation phenomena. Two shabti had cracked open a year after display, exposing extremely fragile core material (fig.1). Nine others showed crumbling, cracks, chipped glaze, and even disintegration. Although Egyptian faience is often claimed to be fragile, it was unclear why these specific shabti were damaged. Therefore, questions were raised about the vulnerability and conservation of Egyptian faience. As information on storage and past conservation treatments was lacking and there was no indication of the presence of soluble salts, research focused on degradation related to different production techniques.

PRODUCTION TECHNIQUES

The different components for the production of Egyptian faience were mixed with water to form a paste and then pressed into open paste molds. After drying, they were fired at ca. 800 - 1000°C. The use of three different glazing methods in particular, has profoundly affected the microstructure and composition of Egyptian faience. “Efflorescence glazing” involved an interior process, where the alkali salts migrated to the surface upon drying and formed an efflorescent outer layer (3). This layer melted during firing and fused with the silica, lime and metal oxides to form a glaze. “Cementation glazing” is an exterior process and involved burying the object in a vessel with a glazing powder rich in flux content (sodium oxides and copper compounds). After firing, the object was left to cool down and alkaline and copper compounds migrated into the body, reacting with it and forming a glaze (1). “Application glazing”, finally, is also an exterior technique and concerned direct application of the glaze (4). As recognition of the glazing method with the naked eye is complicated, analytical tools have been used to identify which techniques were applied for the production of the shabti that show degradation phenomena.

IDENTIFICATION OF GLAZING METHODS

Observations made with optical microscopy suggest that shabti with particularly fragile core material were produced with exterior methods. Samples from four of these objects were also studied with Scanning Electron Microscopy/Energy Dispersive X-ray Spectroscopy (SEM-EDX), in cooperation with the Dutch Cultural Heritage Agency (RCE). Despite the challenges in

identification of production methods, the results seem to confirm these observations. A gradual decrease of copper oxide from the glaze towards the core, a lack of interparticle glass in the body and the thickness of the glaze layer are criteria established by scholars such as Tite (5), Liang (2) and Matin (3). These helped to identify the use of exterior glazing methods (fig. 2).

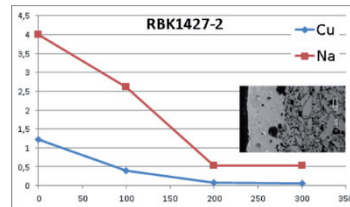


Fig. 1 – This broken shabti contains very friable core material. (Image: De Regt, 2017).

Fig. 2 – SEM image belonging to a sample from a damaged shabti. The EDX data show a gradual decrease of sodium and copper oxides from glaze to core. (Image: Megens, 2018).

RESULTS

A high silica percentage and the absence of interparticle glass in the body of the exterior glazed shabti has resulted in fragile objects with lack of cohesion. The relatively thick glaze layer keeps the friable body together, but is interrupted by production related cracks on the surface. As a result, the vulnerable and porous core material is exposed and the objects are more susceptible to degradation.

This research has shown that Egyptian faience shabti should be handled and treated with great care. Acquiring better insight into production related vulnerabilities may eventually benefit handling, storage and conservation treatment of this material.

Key-words: Egyptian faience, glazing techniques, degradation, SEM-EDX analysis

BIBLIOGRAPHIC REFERENCES

- [1] LA DELFA, Salvatore, FORMISANO, Veronica and CILIBERTO, Enrico – *Laboratory Production of Egyptian Faiences and their Characterization*. Journal of Cultural Heritage 9, 2008, e114.
- [2] LIANG, Haida, SAX, Margaret, SAUNDERS, David and TITE, Mike – *Optical Coherence Tomography for the Non-Invasive Investigation of the Microstructure of Ancient Egyptian Faience*. Journal of Archaeological Science, 39, no. 12, 2012, 3683 – 3690.
- [3] MATIN, Mehran and MATIN, Moujan – *Egyptian Faience Glazing by the Cementation Method, Part 1: An Investigation of the Glazing Powder Composition and Glazing Mechanism*. Journal of the Archaeological Science, 39, no. 3, 2012, 763-767.
- [4] NICHOLSON, Paul T. – *Materials and technology*. In: Gifts of the Nile: Ancient Egyptian Faience, edited by Florence Dunn Friedmann, 50-64; 164-176. London: Thames and Hudson, 1998: 54.
- [5] TITE, Michael S., MANTI, Panagiota, SHORTLAND, Andrew J. – *A technological study of ancient faience from Egypt*. Journal of Archaeological Science, 34, no. 10, 2007, 1568-1583.

Influence of the production technology on the morphological characteristics of azulejos

Sílvia R. M. Pereira¹, M^a Augusta Antunes¹, Ana Margarida Cardoso², Mafalda Costa², José Delgado Rodrigues¹, Lurdes Esteves³, José Mirão², António Candeias² and João M. Mimoso¹

¹ National Laboratory for Civil Engineering and Hercules Laboratory-Evora University, Portugal, spereira@lnec.pt

² Hercules Laboratory-Évora University, Evora, Portugal, amcardoso@uevora.pt

³ National Tile Museum, Lisbon, Portugal, mesteves@mnazulejo.dgpc.pt

SUMMARY

A better understanding of the glaze-ceramics interactions and the resulting interface is essential to understand the azulejo as a composite material and consequently its degradation mechanisms and possible conservation solutions. The results of the metamorphosis by firing help us also to interpret what is seen on actual historic azulejos and to try to unravel their production technology.

In this part of the study some aspects of the production technology connected with the preparation of glaze and biscuit and with the firing cycle have been researched to better understand their effects on the morphological characteristics of the glaze and glaze-ceramic interface [1]. A set of azulejo reproductions has been prepared by using raw and fired ceramic bodies glazed with frit or raw glazes obtained with different quartz grain sizes, firing temperatures and duration of the firing cycle. The resulting cross-sections of the ceramic reproductions were analysed with SEM-EDS.

An increase in the Pb enriched K-Feldspars formed at the glaze-ceramic body interface is observed for higher maximum temperatures, raw glazes, single firings and slower cooling velocities (Table 1).

Table 1 – Interface of tiles glazed with raw or frit glaze powders fired at 950°C.

	C0*	C1*	C2*
FC2- Raw			
FC2- Frit			

* Raw paste (C0), paste fired at 500°C (C1) and paste fired at 1000°C (C2)

The results led to a better interpretation of the technological fingerprint observed on historic glazed tiles and get better insights into the azulejo production technologies and nature of the glaze-ceramic interface.

Key-words: *Majolica* reproductions, azulejo, interface, production technology

ACKNOWLEDGEMENTS

S. Pereira acknowledges FCT, the Portuguese Foundation for Science and Technology, for her Post-Doc Grant (SFRH/BPD/116807/2016). Communication produced as an outcome of Project FCT-AzuRe - Estudos no Azulejo Português para Candidatura a Património da Humanidade (PTDC/EPH-PAT/5096/2014) also funded by FCT.

BIBLIOGRAPHIC REFERENCE

[1] Molera J, Pradell T, Salvadó N, Vendrell-Saz M, 2001, Interactions between clay bodies and lead glazes, J. Am. Ceram. Soc., 84, 5, 1120-28

Glaze composition of 17th - 18th century Dutch Delftware

Annelies van Hoesel¹, Neha Verma¹, Jolanda van Iperen¹ and Femke Diercks¹

¹Rijksmuseum, Amsterdam, The Netherlands, a.van.hoesel@rijksmuseum.nl

SUMMARY

The Rijksmuseum is working on a new catalogue of its collection of Dutch Delftware, in which art historical information is combined with the outcome of analytical material research. The goal of the technical part of the project is to enhance the understanding of the glaze technology and provide scientific support for the attribution of objects to specific periods and places of production using non-destructive methods. This research focusses on the composition of the white tin-glaze and blue inglaze decoration of approximately 450 marked objects dating from the 17th and 18th centuries and attributed to several factories in the town of Delft. The elemental composition of the white glaze and the blue decoration is determined with X-ray fluorescence spectroscopy (XRF). Spectra are processed using the PyMCA software. Previous LA-ICPMS analyses of selected samples will be used to validate the elemental concentrations.

WHITE GLAZE & KWAART

The results of the first 75 Delftware objects show that the composition of the white tin-glaze varies over time, reflecting changes in the raw ingredients as well as in the production process. The first clear changes occurred at the end of the 17th century. At this time an unexpected drop in zinc relative to lead, for which the reason is currently under investigation. Most likely it is related to synchronic decrease in copper as zinc is a known impurity in copper, which is used in the glaze¹. Around the same time the low energy Sn-L lines peaks disappeared from the spectra. This is caused by the absorption of the low energy X-rays by the lead from the so-called *kwaart*¹, which is a thin lead overglaze applied to enhance the gloss and deepens the colours (Figure 1). In the 2nd half of the 18th century the Sn-L peaks appeared again, while the zinc stayed low. These results suggest that in general, objects without a *kwaart* but with a higher amount of zinc, were produced in the 17th century, whereas objects without a *kwaart* but with a lower amount of zinc date to the 2nd half of the 18th century.

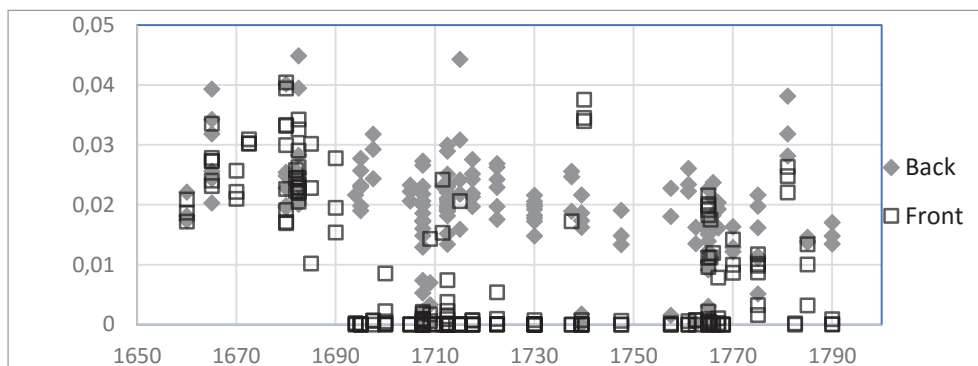


Figure 1 – Sn-L/Sn-K ratio of the white glaze at the front and back in relation to the age of the object.

DECORATION

Trends in the composition of the blue cobalt pigment used for the decoration are more difficult to observe because of the variable thickness of the decorative layer. Nevertheless, a small increase in nickel and bismuth compared to cobalt is observed near the start of the 18th century. This change might reflect a shift to a less refined cobalt pigment, containing more impurities.

TREK

More than two-thirds of the measured objects contain a so-called 'trek', the outline of the decorative elements. The colour ranges from a shade of blue similar to that of the decoration, to darker hues of blue and black. The blue trek usually contains cobalt with small amounts of iron rust1 and manganese oxide, although manganese was not found in the blue trek of the objects from the Porceleyne Byl or the Witte Starre. The black trek usually contains iron and manganese mixed with some cobalt. However, in a certain subset of polychrome objects from the Grieksche A factory, the black outline was created using copper oxide instead.

CONCLUSIONS

Based on the preliminary results of the XRF analyses it is concluded that objects can be attributed to a production period based on the composition of the white glaze. In addition the composition of the trek can be used to narrow down the possible factories. These findings are vital in the process of re-evaluating and confirming traditional art historical viewpoints and attributions using technical research.

Key-words: Delftware, XRF, tin-glaze, cobalt, kvaart

BIBLIOGRAPHIC REFERENCES

[1] PAAPE, Gerrit – *De Plateelbakker of Delftsch Aardewerkmaaker, Volledige beschrijving van alle konsten, ambachten, handwerken, fabrieken, trafieken, derzelve werkhuisen, gereedschappen, enz. Volume 12*, Dordrecht, 1794 (facsimile Amsterdam 1978).

Understanding 17-18th century Dutch Tin-glaze Through the Interpretation and Reconstruction of Historical Recipes

Kate van Lookeren Campagne¹, Luc Megens² and Maarten van Bommel¹

¹ University of Amsterdam, Amsterdam, Netherlands, K.E. vanLookerenCampagne@gmail.com

² Cultural Heritage Agency of the Netherlands, Amsterdam, Netherlands
L.Megens@cultureelerfgoed.nl

SUMMARY

Historical glaze recipes can provide important information on the source materials used for glaze production and insight into the working practices of potters as well variations in glaze characteristics that may help us understand susceptibility to glaze deterioration.

This research focusses on an 18th century hand-written recipe book (Figure 1) which describes over 75 (primarily) Dutch tin-glaze recipes dated between 1659 and 1755 used for both tile and object production. The recipes give details of the sources and quantities of the raw materials needed to produce tin glaze, then made from two components: *Masticot* (a glass produced from sand and fluxes) and *tin* (tin- and lead oxides used for colour and gloss). The variations in the recipes provide important information: how glaze recipes have changed over time, the fact that different glazes were used for tiles and objects, and the deliberate production of different qualities of glaze.

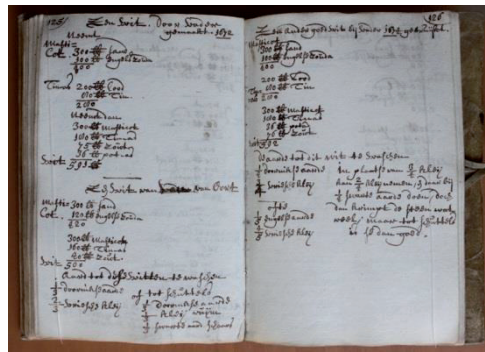


Figure 1 – Page 25 of Petrus Sijbeda’s recipe book with Harlingen tin-glaze and clay- mix recipes dated 1672 and 1674

The glaze recipes described in the book have been compared with other historical tin-glaze recipes (Biringuccio, Piccolpasso, regarding the source, composition and use of fluxes used in the recipes, in particular the composition of the sodium carbonate or *soda* (from Alicante or Scotland) well as the common salt added final frit which is described in written sources as being essential to obtain a whiter glaze colour.

Three glaze recipes have been reconstructed: a high-quality and a low-quality glaze from the Sijbeda book (Figure 2). The glaze recipes were created using pure chemical components, taking into account SEM-EDS analytical results. The glaze reconstruction protocol followed the historical process as closely as possible within the feasible health and practical limitations, the components of the *Masticot* recipes and final glaze being mixed and fired on a sand-bed on the bottom of the kiln. The influence of common salt (sodium chloride) was assessed by creating

two recipes using sodium carbonate and sodium chloride. The firing protocol (temperature, firing time and soaking period) was formulated from what is known about both the kilns and firing procedures of the period. The glazes were applied to ceramic test tiles that had already been produced from historical clay recipes.

The results of the recipe interpretation, glaze reconstruction and preliminary glaze tests have provided new insight into the composition and effect of raw materials used in Dutch tin-glaze production, in particular the fluxes (*soda and potash*) and common salt which appears to have a bleaching effect. Furthermore, this research has led to a better understanding of the production and firing process and shown that different recipes were used for objects and tiles.

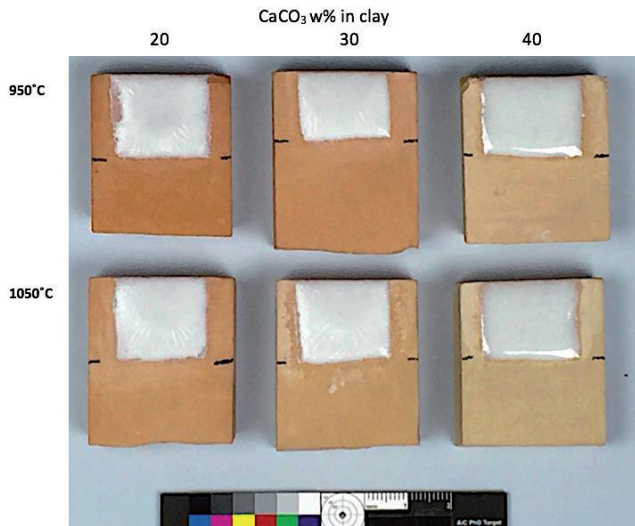


Figure 2 – Reconstruction of a historical glaze described by Sijbeda glaze on test tiles where the clay had 20/30/40 w% CaCO₃. The temperatures given are the temperature used for the initial ‘biscuit’ firing of the ceramic test tile.

Key-words: Tin-glaze, Dutch Tiles, Historical glaze recipes

Improving data exploration methods from macro imaging techniques: in situ scanning macro-XRF investigation on a majolica tile tableau

Marco Colombo^{1,2}, Stijn Legrand², Geert Van der Snickt², Koen Janssens²

¹*School of Science, University of Bologna, Ravenna, Italy, marco.colombo8@studio.unibo.it*

²*Department of Chemistry, AXES research group, University of Antwerp, Antwerp, Belgium, marco.colombo@student.uantwerpen.be*

SUMMARY

The application of analytical techniques to the study of majolica artefacts and artworks has led to a considerable progress in the knowledge of its production technology. Furthermore, these techniques allow researchers to distinguish between objects that may have a similar appearance, but that were made using different raw materials. However, to obtain reliable stratigraphic information of majolica objects, invasive techniques are often employed, as in the work of Pérez-Arategui [1]. Instead, in the area of cultural heritage studies there is a special need for in-situ non-destructive and mobile techniques, since often ceramic artefacts and artworks cannot be moved. The development and the use of these mobile devices is therefore fundamental in ceramic conservation science. For the aforementioned reasons, in this project a state-of-the-art method for non-invasive visualization of (sub)surface layers present in works of art was employed for the first time. The aim was to study ceramic artefacts and artworks, and more specifically: six ceramic tiles of different origins, and an Antwerp majolica tile tableau manufactured in the mid of the 16th century, as suggested by Caignie [2]. Macroscopic X-ray fluorescence scanning (MA-XRF), a technique developed by Alfeld [3] over the last decade for the investigation of historical paintings, was used to (a) determine the characteristic elements of the renaissance majolica production process and the pigments that were used for the colourful motifs present on these majolica tiles (b) gain new insights on the late 19th century Villeroy & Boch ceramic tiles manufacturing process.

MA-XRF data were processed by means of the software package PyMCA developed by Solé [4], and the in-house written software Datamuncher developed by Alfeld [5] to obtain, as output, the elemental distribution maps of the chemical elements present over the (sub)surface. Furthermore, a careful interpretation of the ensuing elemental distribution images allowed to visualize the earlier retouchings present in the tiles. By using the software package Datamuncher, it was possible to obtain meaningful scatter plots of elements that were thought to be present together in the mixtures in order to obtain the desired hues. The last operation was extremely important to get, also thanks to the usage of the software package PyMCA, new insights on the manufacture and the possible pigments used in the tiles probably made by the Villeroy & Boch ceramic factory. The processing and the interpretation of the data coming from the MA-XRF scans that were performed on the majolica tile tableau, aimed to identify the most relevant differences between the pigments used in the tableau and the pigments used in the four majolica tiles present on the six tiles previously scanned; as well as to compare their chemical makeup in order to identify pigments that are not present in the four majolica tiles present on the six tiles, and to make an overall distinction between the original and the restored areas in the tableau, confirming the presence of materials and pigments that are not present in the authentic areas. The MA-XRF scanner and its setup parameters for the measurements that were performed on the majolica tile tableau, were the same to the ones used to scan the six tiles. MA-XRF scans were performed by sweeping the measuring head systematically over the tiles surface in serpentine mode.

MA-XRF scanning, with the advantage of its mobility and non-destructiveness, proved to be highly useful in the study of these ceramic artefacts and artworks. The elemental distribution images obtained by MA-XRF provided additional information, allowing to answer open questions and helping in the discrimination between authentic and inauthentic tiles. This allows to support conservation treatments. In addition, this work emphasises the possibility to distinguishing the main features of the Villeroy & Boch ceramic production, poorly mentioned due to scarcely-existing information.

For all these reasons we foresee the application of MA-XRF in future projects regarding high-profile ceramic objects, especially when a non-contact and non-invasive diagnostic technique is needed.

Key-words: Ceramics, MA-XRF, Non-destructive analysis, Tiles

BIBLIOGRAPHIC REFERENCES

¹ PÉREZ-ARANTEGUI, J., MONTULL, B., RESANO, M., ORTEGA, M. J. - *Materials and technological evolution of ancient cobalt-blue-decorated ceramics: Pigments and work patterns in tin-glazed objects from Aragon (Spain) from the 15th to the 18th century AD*. European Ceramic Society, 29, 2009, 2499-2509.

² CAIGNIE, Frans - *Majolicategels in het MAS | collectie Vleeshuis*. Version 2. Studierapport, Antwerp, April 2015.

³ ALFELD, M., JANSSENS, K., DIK, J., DE NOLF, W., VAN DER SNICKT, G. - *Optimization of mobile scanning macro-XRF systems for the in-situ investigation of historical paintings*. Analytical Atomic Spectrometry, 26, 2011, 899-909.

⁴ SOLÉ, V. A., PAPILLON, E., COTTE, M., WALTER, P., SUSINI, J. - *A multiplatform code for the analysis of energy-dispersive X-ray fluorescence spectra*. Spectrochimica Acta Part B, 62, 2007, 63-68.

⁵ ALFELD, M., JANSSENS, K. - *Strategies for processing mega-pixel X-ray fluorescence hyperspectral data: a case study on a version of Caravaggio's painting Supper at Emmaus*. Analytical Atomic Spectrometry, 30, 2015, 777-789.

Mortars for the reattachment of old tiles: characteristics needed for preservation of azulejos claddings

Maria do Rosário Veiga¹

¹ *Laboratório Nacional de Engenharia Civil (LNEC), Lisbon, Portugal, rveiga@lnec.pt*

SUMMARY

Azulejos (glazed ceramic tiles) have been used for wall claddings in Portugal at least from the 16th century until present. Until the 19th century they were used mainly in important constructions and as decorative elements in interior wall surfaces. In the 19th century, industrialization allowed their use also in simple housing buildings, and as an external façade cladding, with both protective and aesthetic functions [1]. The historic *azulejos* have higher water absorption and generally higher capillary coefficient than the contemporary ones [1,2]. The use of modern adhesives specifically developed for the bonding of contemporary tiles cladding façades is not suitable for the reattachment of the old ones, due to incompatibility both with the old substrates and the ancient *azulejos*.

OLD SETTING MORTARS FOR AZULEJOS CLADDINGS

Research on old *azulejos* setting mortars in Portugal, in the large period between the 16th century and the middle of the 20th century, both in internal and external walls applications, is still quite restrict, but the data collected until now evidence the following characteristics [3]: the binder is air lime generally calcitic but in some cases (e.g. Coimbra case studies) dolomitic lime; the aggregates are siliceous, sometimes with a proportion of clay; Ratios lime : aggregate are mainly between 1:2 and 1:6 (in weight); compressive strength mainly between 0.5 and 3.5 MPa; capillarity coefficient between 1 and 3 kg/m².min^{1/2}.

REQUIREMENTS AND POSSIBLE SOLUTIONS

The requirements to take into account for reattachment mortars for old *azulejos* are related with: compatibility, reversibility, functionality and durability. The different types of requirements are often contradictory, so an adequate balance must be reached. The most important requirements are [4,5]: good workability and ability to penetrate in the ceramic body of the *azulejo* and high water retention; enough mechanical strength for adhesion under the tiles' weight (preventing falling of *azulejos*) but lower than the substrate's for reversibility and for preventing damage of the masonry; avoid high modulus of elasticity; adhesion strength is a key property for durability and functionality of the system, however, it should not be too high, to prevent damaging the substrate and also to allow reversibility; ability to dry fast and high water vapour permeability, to prevent concentration of moisture and affecting adhesion; all the components must be free of soluble salts, in order to avoid contamination of the system with additional salts .

Modern adhesives and cement mortars should not be used, being too high-strength, and low-porosity materials. The same goes, to a certain extent, for hydraulic lime mortars with the exception of natural hydraulic lime (NHL) lime mortars which have limited salt contents.

Based on the knowledge of old setting mortars and on experimental studies the following compositions proved to be the most adequate [6]: Binders: Air lime; natural hydraulic lime (NHL); air lime and pozzolans; Aggregates: Well graded siliceous sand with a certain amount of fine grains and or small amounts of non-expansive clay; raw materials free of significant amounts of soluble salts. Some compositions having shown good results in tests are (proportions in volume): Air lime: siliceous aggregate 1:2; Air lime + pozzollan (e.g. metakaolin) : siliceous

aggregate 1:2; NHL 3.5 : siliceous aggregate 1:3 (use only with medium strength masonry and tiles).

CONCLUSIONS

Old *azulejos* claddings, both internal panels and claddings of 19th century façades, although they have proved good durability, are now often in urgent need of repair, to avoid fall and loss of historical *azulejos*. The reattachment of old *azulejos* should be made with adequate mortars, respecting requirements of compatibility and reversibility, as well as functionality and durability. Modern adhesive mortars, or any mortars with too high strength, high stiffness, low water vapour permeability or significant contents of soluble salts are to be avoided. Instead, lime-based mortars, with moderate mechanical and hygric characteristics and free of salts, must be used. Air lime, air lime and pozzolan, or natural hydraulic lime (NHL 3.5) may be used as binders and well graded siliceous sand, with small amounts of clay or filler should be used as aggregates, providing adhesion strength to the tiles and to the masonry in the range 0.05-0.15 MPa.

Key-words: Azulejos cladding; reattachment of azulejos; setting mortar; adhesion; compatibility requirements.

REFERENCES

- ¹ BOTAS, S.; VEIGA, M. R.; VELOSA, A. – *Adhesion of Air Lime-Based Mortars to Old Tiles: Moisture and Open Porosity Influence in Tile/Mortar Interfaces*. J. Mater. Civ. Eng., 27(5), 2015, 04014161.
- ² BOTAS, S.; VEIGA, M. R.; VELOSA, A. L. – *Adherence evaluation in tile-mortar interface*. Mat. Sc. Forum 730-732, 2013, 403-408. DOI:104028/www.scientific.net/MSF.730-732.403.
- ³ DAMAS, A.L.; VEIGA, M.R.; FARIA, P.; SANTOS SILVA, A. – *Characterisation of old azulejos setting mortars: a contribution to the conservation of this type of coatings*. Const. and Build. Materials, 171, 2018, 128-139.
- ⁴ VEIGA, M.R.; FARIA, P. – *O papel das argamassas na durabilidade das alvenarias antigas*. In Proc. of Conf. Int. sobre Reabilitação de Estruturas Antigas de Alvenaria, CIRea, 2018.
- ⁵ BOTAS, S.; VEIGA, R.; VELOSA, A. – *Air lime mortars for conservation of historic tiles: Bond strength of new mortars to old tiles*. Const. and Build. Materials, 145 426-434, 2017. DOI: 10.1016/j.conbuildmat.2017.04.027.
- ⁶ BOTAS, S.; VEIGA, R.; VELOSA, A. - *Bond strength in mortar/ceramic tile interface - testing procedure and adequacy evaluation*. Mat. and Str., 2017 50:211. DOI 10.1617/s11527-017-1086-7.

Studies on Azulejo glaze welding by means of laser irradiation

Silvia R. M. Pereira^{1,2}, Kostas Hatzigiannakis³, Eleni Polychronaki³, Kristallia Melessanaki³, Paraskevi Pouli³ and João M. Mimoso¹

¹ *National Laboratory for Civil Engineering, Lisbon, Portugal, spereira@lnec.pt*

² *Hercules Laboratory - Évora University, Évora, Portugal*

³ *Institute of Electronic Structure and Laser, Foundation for Research and Technology-Hellas (IESL-FORTH), Heraklion, Crete, Greece, kostas@iesl.forth.gr*

SUMMARY

Azulejos (Portuguese historic glazed tiles) suffer from pathologies such as glaze fissures and lacunae especially as a result of exposure to weathering conditions and wall moisture. Many tile panels are badly in need of conservation but there is currently a lack of efficient and adequate solutions. Lasers offer a number of unique advantages and thus they have been established as invaluable tools for the study and conservation of CH objects and Monuments. In the conservation/restoration field, up to now the attention of the scientific community has been focused mainly on the laser cleaning processes. In this communication the initial studies of a novel application of laser radiation based on the controlled thermal fusion of the glaze [1] are presented and its potential for the restoration of azulejo discussed. The influence of a CO₂ laser processing parameters (working distance, beam velocity, number of laser scans) have been tested in order to see their effect upon the welding of ceramic glazed surfaces. Tile replica of different glaze compositions and pigmented – non pigmented glazes, have been irradiated. Optical, Reflection and SEM microscopy have been used to study the morphological alterations and impact upon the laser irradiated glaze.

CONCLUSIONS

The laser was able to melt the irradiated areas. In some cases, an increased gloss, crazing (Figure 1) and yellowing was observed in the irradiated areas with accumulated energy density. In general, the melted lines width irradiated with higher accumulated energy (slower speeds and closer to the focus) are wider. However, the composition and presence of pigments of the glaze (due to differences in the melting point) are shown to also greatly affect the melted pool. The number of beam scans seems to be determinant up to a certain point (15-50 scans) after which no substantial gain is observed. The pre and post-heating temperature tested (300°C) proved to not be sufficient to decrease crazing. Novel methods would need to be tested to decrease and ideally eliminate the resulting crazing. The results obtained show that great care should be put in the selection of the laser parameters; the distance to the glaze surface (working distance) plays a great role, but also velocity and number of beam passages. These optimization of parameters varies however when applying the irradiation on variations of types of glaze and even in different pigmented areas of the same glazed tile. An initial optimization would need to be made and the laser parameters adapted to the specific glaze on and pigments of the substrate. Notwithstanding the necessary optimizations, CO₂ laser welding is a promising technique to treat ceramic tile and is something that needs and deserves to be better researched. Initial results are encouraging and further work towards the on-site and real-case implementation of this methodology is in progress.

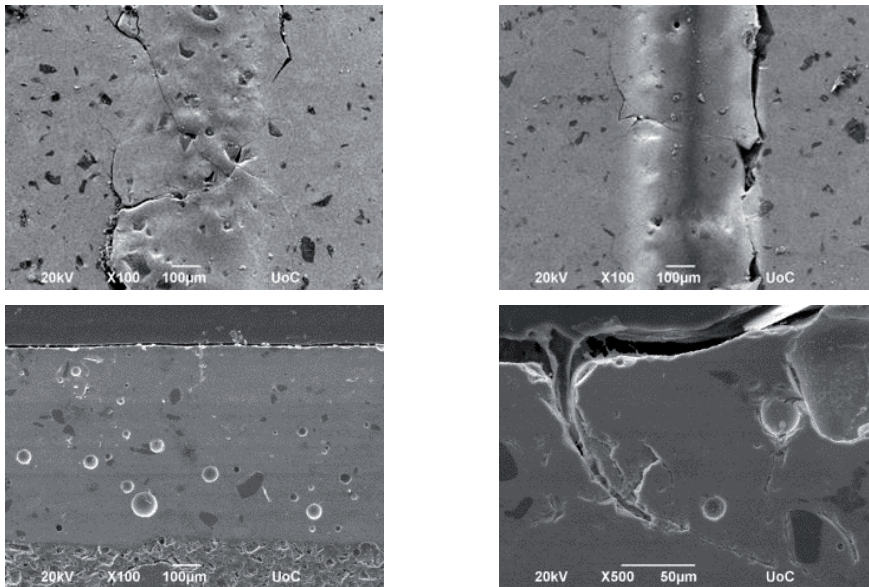


Figure 1 – SEM analysis of R1 samples irradiated with different working distances and number of scans. Depending on the local the cross section is made the fissure between the melted and non-melted glaze can be seen or not.

Key-words: Laser, Azulejo, Restoration, glazed ceramics

ACKNOWLEDGMENTS

The research has received funding from LASERLAB-EUROPE (grant agreement no. ulf-forth 002342, EU's Horizon 2020 research and innovation programme). S. Pereira acknowledges FCT for her Post-Doc Grant (SFRH/BPD/116807/2016). We acknowledge support of this work by the project "Advanced analytical, diagnostic, surveying and documentation technologies in Cultural Heritage (POLITEIA-II)" (MIS 5002478) which is implemented under the "Action for the Strategic Development on the Research and Technological Sector", funded by the Operational Programme "Competitiveness, Entrepreneurship and Innovation" (NSRF 2014-2020) and co-financed by Greece and the European Union (European Regional Development Fund).

REFERENCES

[1] Chatzigiannakis, K. et al, Restoration of vitreous surfaces using laser technology, PCT/GR2016/000011, WO/2017/158390.

Validation of contactless vibro-acoustic imaging for the detection of glaze delamination in glazed ceramic tiles

Paola Calicchia¹, Sara De Simone² and Simone Privitera³

¹ Institute of Marine Engineering CNR-INM, Rome, Italy, paola.calicchia@cnr.it

² Institute of Marine Engineering CNR-INM, Rome, Italy, paola.calicchia@cnr.it

³ University of Rome Tor Vergata, Rome, Italy, privi.simone@hotmail.it

SUMMARY

For glazed ceramic tiles, glaze delamination is a decay problem greatly demanding for effective risk-based preventive conservation. The present study faces the problem of the early detection of adhesion failure between the glaze and the clay substrate, exploring the potential of a vibro-acoustic imaging (VAI) technique in helping to prevent the glaze falls off and lacunas. The imaging technique is based on the Laser Doppler Vibrometry (LDV) joint to a contactless acoustic excitation of the tiles in the frequency interval (1 - 20) kHz. The results on historical Portuguese azulejos and laboratory models demonstrate that hidden cavities, a few hundreds of microns deep, are correctly identified and characterized.

Although azulejos are a durable architectural finishing, many forms of deterioration progress leading to the final loss of the painted glazed layer and impair the comprehension of the related pictorial program. Glaze delamination and spalling is a severe problem for the conservation of antique azulejos and the preservation of their value.

The vibro-acoustic imaging based on Laser Doppler Vibrometry is proposed for the early detection of glaze delamination, showing the images of hidden cavities a few hundreds of microns deep, and the indication about the probable stage of deterioration (incipient or advanced). For this investigation a heterogeneous set of sample were analysed encompassing two historical Portuguese azulejo (A1, A7) and five laboratory models (T1, T3, T11, T12, T13). The azulejo sample A1 presents no apparent glaze delamination, while A7 is affected by an evident glaze delamination and a lacuna. The laboratory models were realized assembling thin technical glasses on clay substrates using epoxy glue; they include one reference sample with no cavity (T3) and four models with artificial cavities having different shape and depth. Table 1 reports the characteristics of these four models.

Table 1: List of laboratory models with artificial cavities and details about their size.

T1- square (mm3)	T11- square (mm3)	T12- square (mm3)	T13- triangular (mm3)
42 × 42 × 1.0	34 × 37 × 0.8	37 × 37 × 0.4	35 × 28 × 0.6

The laboratory validation of the diagnostic method addresses three principal objectives: i) reveal hidden cavities with different depth and shape; ii) correlate the cavity depth to characteristic features of the target acoustic response; iii) provide indications about the decay evolution in real tiles. A number of vibro-acoustic images, displaying the velocity of vibration in the most significant frequency bands, are discussed in the paper in relation to these objectives.

Figure 1 shows the most representative vibro-acoustic image of each sample. For the laboratory models with hidden cavities we notice a considerably different behaviour with respect to the reference model T3, and also the discrimination of the hidden cavity from points with perfect adherence on the same sample. The availability of models with cavities a few hundreds of microns deep allows to demonstrate that the vibro-acoustic imaging in the audio frequency interval

successfully reveals the position of thick and thin delaminations, and approximately identifies their shape and extension. As expected, the vibration frequency grows as the cavity depth decreases.

Regarding the two azulejos, we notice the light vibration of A1 in a relatively high frequency band, 10 kHz, that denotes the potential presence of an incipient delamination process though any other relevant feature is present. Conversely the sample A7 presents a number of evident critical areas, indicating that the decay process is mainly advancing in the third quadrant, at the bottom-left sector of the tile, and in the first quadrant near the upper-right border.

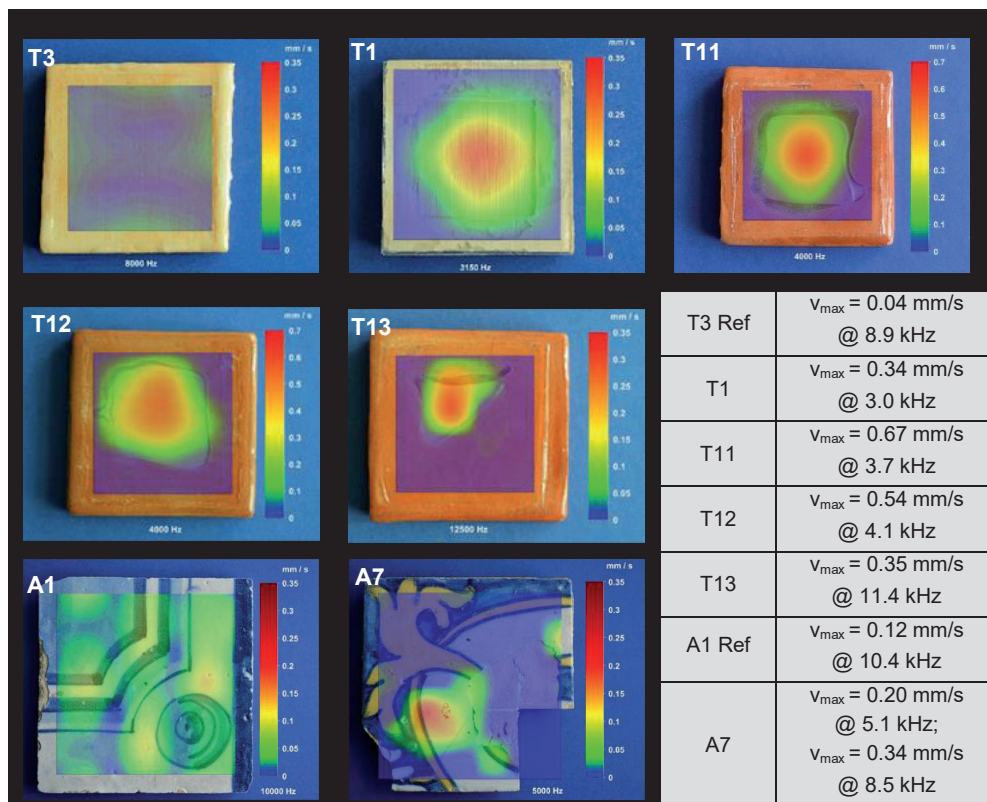


Figure 1 – Selection of the most significant vibro-acoustic images of the analysed sample. The main velocity peaks v_{max} and the respective frequency are indicated in the table.

Key-words: Preventive conservation; Glaze delamination; Vibro-acoustic imaging.

The implementation of computer-match pigment selection for overcoming metamerism in ceramic glaze reinstatement

Norman H. Tennent¹, Isabelle Garachon², James H. Nobbs³, Mandy Slager⁴ and Bouke de Vries⁵

¹ University of Texas, Dallas, USA *normantennent@yahoo.co.uk*

² Rijksmuseum, Amsterdam, NL *i.garachon@rijksmuseum.nl*

³ Colour4Free, Leeds, UK *james.nobbs@gmail.com*

⁴ Restauratieatelier Mandy Slager, Leiden, NL *msluger@conservering.nl*

⁵ De Vries Conservation, London, UK *bouke@boukedevries.com*

SUMMARY

This contribution will centre on the research conducted to assess the use of computer-match pigment selection (CMPS) in order to overcome metamerism. During the reinstatement of missing glazes, metamerism is a common troublesome feature faced by ceramic conservators. The colour of restored glaze areas (predominantly those with blue hues), in-painted using pigment mixtures in a polymer medium, often matches the original glaze under the lighting of the conservation studio but appears very different in other lighting conditions. Previous research [1] has demonstrated the potential of CMPS to provide non-metameric pigment combinations which match the original glazes for all light sources but the implementation of this in practice has necessitated further experimentation in conjunction with conservators.

This paper gives prime attention to evaluation of CMPS matching recipes carried out by experienced ceramics conservators. The ceramics used include Portuguese tiles and Dutch tin-glazed earthenware. Colour matching has also been assessed using a range of glossy blue printed samples from a commercial paint company. The results reported will cover:

- the ease of achieving a good colour match from the CMPS recipe pigment percentages,
- comparisons of the CMPS colour matches with corresponding results using conservators' own pigment choices,
- the potentiality for selection of a small palette of the most suitable pigments for non-metameric matches of blue ceramic glazes
- the helpful variations in appearance achievable by the choice of white pigment selected, namely lead, zinc or titanium white.

Key-words: Metamerism, colour-matching, in-painting, blue glazes

BIBLIOGRAPHIC REFERENCE

1. N. H. Tennent, J. H. Nobbs, M. Binns and S. P. Lawton, "The use of computer-match colour prediction in the restoration of ceramics", Preprints of ICOM-CC 14th Triennial Meeting, The Hague, (2005) 146-153

Biodeterioration of glazed tiles: case studies and novel laboratory-based approaches

Mathilda L. Coutinho¹, Ana Z. Miller² and Maria Filomena Macedo³

¹ Research Unit VICARTE – Glass and Ceramics for the Arts, Faculdade de Ciências e Tecnologia, Universidade NOVA de Lisboa, Caparica, Portugal, mathildal@gmail.com

² Instituto de Recursos Naturales y Agrobiología de Sevilla (IRNAS-CSIC), Seville, Spain, anamiller@irnas.csic.es

³ Department of Conservation and Restoration and Research Unit VICARTE – Glass and Ceramics for the Arts, Faculdade de Ciências e Tecnologia, Universidade NOVA de Lisboa, Caparica, Portugal mfmd@fct.unl.pt

SUMMARY

The impact of microbial activity on the deterioration of cultural heritage is a well-recognized global problem. Glazed wall tiles constitute an important part of the worldwide cultural heritage. When exposed outdoors, biological colonization and consequently biodeterioration may occur. Few studies have dealt with this issue, as shown in the literature review on biodiversity, biodeterioration and bioreceptivity of architectural ceramic materials ^[1].

Due to the lack of knowledge on the biodeteriogens affecting these assets, the characterization of microbial communities growing on Portuguese majolica glazed tiles from Pena National Palace (Sintra, Portugal) and Casa da Pesca (Oeiras, Portugal) (Fig. 1) was carried out by culture and molecular biology techniques. The characterization of these microbial communities revealed a complex biofilm composed of microalgae, cyanobacteria, bacteria and fungi ^[2,3].

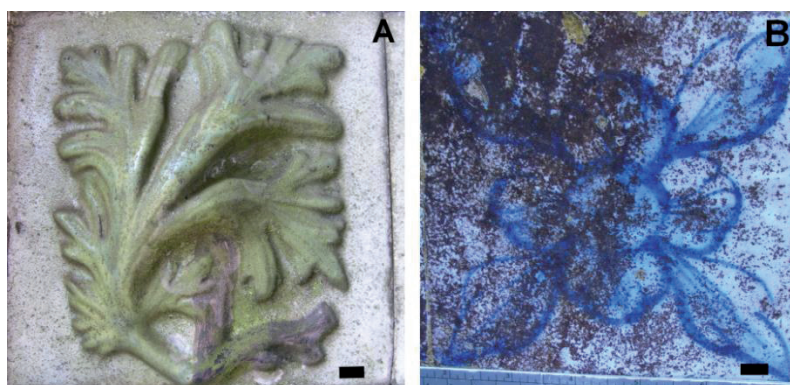


Figure 1 – Glazed tiles with biological colonization. Tile from Pena Nacional Palace with dark green microbial biofilme (A) and tile from *Casa da Pesca* in Oeiras with dark dense microbial biofilm (B) (black line 1 cm).

Laboratory-based colonization experiments were performed to assess the biodeterioration patterns and bioreceptivity of glazed wall tiles produced in laboratory. Microorganisms previously identified on glazed tile cultural assets were inoculated on pristine and artificially aged tile models and incubated under laboratory conditions for 12 months. Phototrophic microorganisms were able to grow into glaze fissures and the tested fungus was able to form

oxalates over the glaze. The results in terms of bioreceptivity to phototrophic microorganisms showed that artificially aged tiles were more bioreceptive than pristine tile models^[4].

A preliminary approach on the mitigation strategies based on *in situ* application of commercial biocides and titanium dioxide (TiO₂) nanoparticles on glazed tiles demonstrated that commercial biocides did not provide long term effectiveness^[3]. In contrast, the TiO₂ treatment caused biofilm detachment from the tile surface. In addition, the use of TiO₂ thin films on glazed wall tiles as a protective coating to prevent biological colonization was analysed under laboratorial conditions^[3]. Finally, conservation notes on tiles exposed to biological colonization are presented.

Key-words: Glazed tiles, ceramic, microorganisms, biodeterioration and bioreceptivity

ACKNOWLEDGEMENTS

This study was supported by *Fundação para a Ciência e a Tecnologia* (FCT) under the PhD grant SFRH/BD/46038/2008 and Vicarte - UID/EAT/00729/2013.

REFERENCES

- [1] COUTINHO, M. L., MILLER, A. Z., MACEDO, M. F. - *Biological colonization and biodeterioration of architectural ceramic materials: An overview* Journal of Cultural Heritage, 16, 2015, 759-777
- [2] COUTINHO, M.L., MILLER, A.Z., GUTIERREZ-PATRICIO, S., HERNANDEZ-MARINE, M., GOMEZ-BOLEA, A., ROGERIO-CANDELERIA, M.A., PHILIPS, A.J.L., JURADO, V., SAIZ-JIMENEZ, C., MACEDO, M.F. - Microbial communities on deteriorated artistic tiles from Pena National Palace (Sintra, Portugal). *International Biodeterioration & Biodegradation* 84, 2013, 322-332.
- [3] COUTINHO, M.L., MILLER, A.Z., MARTIN-SANCHEZ, P.M., MIRÃO, J., GOMEZ-BOLEA, A., MACHADO-MOREIRA, B., CERQUEIRA-ALVES, L., JURADO, V., SAIZ-JIMENEZ, C., LIMA, A., PHILLIPS, A.J.L., PINA, F., MACEDO, M.F. - *A multiproxy approach to evaluate biocidal treatments on biodeteriorated majolica glazed tiles*. *Environmental Microbiology* 18, 2016, 4794-4816.
- [4] COUTINHO, M. L., MILLER, A. Z., ROGERIO-CANDELERIA, M. A., MIRÃO, J., CERQUEIRA ALVES, L., VEIGA, J. P., MACEDO, M. F. - *An integrated approach for assessing the bioreceptivity of glazed tiles to phototrophic microorganisms*. *Biofouling*, 32(3), 2016, 243–259.

A first approach to the tile collection from the Convento de Santana (Lisbon, Portugal)

Mariana Almeida^{1,2}, Rosa Varela Gomes¹ and Mário Varela Gomes¹

¹ *Instituto de Arqueologia e Paleociências da Universidade Nova de Lisboa (Portugal), mariana.brit.almeida@gmail.com*

² *Instituto de História Contemporânea da Universidade Nova de Lisboa (Portugal) and Doctoral fellow SFRH/BD/100982/2014 of the Fundação para a Ciência e Tecnologia (Portugal), Lisbon, Portugal*

SUMMARY

The Santana Convent, Lisbon, which founded in ca 1562 and active until the end of the 19th century, underwent two major excavation campaigns in 2002 and 2009/2010, which revealed several structures and a vast amount of archaeological materials. Amongst those, a collection of almost ten thousand tile sherds stand out. This assemblage comprises the entire chronology of the convent occupation, with examples from every different evolution stage in Portuguese tile production during the convent's long history.

THE CONVENT

This paper stems from the study of the numerous archaeological materials unearthed in the excavations of the Santana Convent in Lisbon. Given the sheer size of the collection, the task of studying this assemblage is laborious and time consuming and, therefore, still unfinished, despite the efforts of a multidisciplinary team. Thus, the data presented here is preliminary, and the overall numbers or some details may be further rectified.

The convent was inhabited by Poor Clares from 1562 up to the late 19th century, in the wake of the dissolution of the monasteries in Portugal. After that, the convent went through deep renovation and refurbishing works, with its original buildings almost completely demolished, in order to be turned into the Real Instituto Bacteriológico de Lisboa and later on Instituto Bacteriológico Câmara Pestana (IBCP).

There were least three large construction and reformulation campaigns during the occupation of the convent, in 1674-1681, 1707 and 1729. Another campaign took place after the earthquake of 1755.

The excavation in the Santana Convent took place in two different campaigns in the context of the transformation of the former IBCP buildings into new facilities for the Faculdade de Ciências Médicas da Universidade Nova de Lisboa (Nova Medical School). The first occurred in 2002, focusing on an area already cleared of buildings, and acted almost as a preliminary survey for archaeological potentiality. The second campaign took place between 2009 e 2010, encompassing the remaining area of the IBCP, at the same time as the actual construction works.

THE TILE COLLECTION

7618 fragmented tiles were gathered in both archaeological campaigns. In addition to the tile fragments gathered during the excavation works, we will also be including information regarding tile panels we safely know were once placed in the Santana Convent and were taken to Madre de Deus Convent in Xabregas in the late 19th century, during its refurbishing to become the IBCP. This information is clearly stated in a report written in 1907, listing and describing these tiles, and the places where some of them were later placed in Xabregas.

Only one small Hispano-Moresque tile fragment was found. It was produced with the *cuerda seca* technique, and given its production type, it is most likely Spanish in origin, from Seville. Two interesting tiles from this period also deserve a mention, they are the earliest examples of tiles in the *maiolica* technique in Santana and present all the characteristics of a 2x2 pattern tile, with a polychromous phytomorphic central motif and a chronology from the second half of the 16th century. They were produced in Talavera de la Reyna, Spain.

Blue, white and green geometric checkered *enxaquetado* tiles were also found in high amounts. It is plausible to assess that the convent tile wall covering in the 16th century was a geometric scheme. In addition to the tiles found during the archaeological excavation, we know that several similar tiles were taken to the Madre de Deus Convent in Xabregas in the late 19th century.

No fragment from a 17th-century figurative panel was found during the excavations. However, in the list of tiles taken from the Convento Santana to Xabregas in the late 19th century, eight such panels are mentioned.

As for pattern tiles, 402 fragmented tiles were found, divided into two groups: polychromous and monochrome. So far 53 distinct patterns were identified, most of them with few copies each, approximately half having less than 5. We have recognized 24 polychromous patterns, 14 monochrome patterns, and 15 which, despite having been registered as polychromous, present a monochrome version. As for typologies, we find the entire pattern spectrum in this assemblage, with 28 patterns, 7 friezes, 16 frames and 6 bars, which is the usual proportion. Most patterns are of the 2x2 type.

The largest amount of tiles found during the excavations correspond to 18th-century panels and their frames. The last category far surpassing the first. Frames present some variations to baroque winding acanthus leaves, and the corner elements show *mascarons*, flowers and *putti*. As for the panels themselves, the tiles are very fractured and the compositions, and overall themes, are very hard to assemble or even understand. Up until now only a small panel from this campaign was put together, depicting Saint Barbara. We know, through the 1907 list, that other three small panels were taken to Xabregas. Some tile fragments found in the excavations have high technical quality and interesting features will be described in the main paper.

The excavation also yielded single figure tiles, with four main motifs: flowers, animals, boats and anthropomorphic depictions. Flowers are the most common theme.

Lastly, we have to mention the albarrada compositions, representing a large trophy like vase, with flowers and fruits, usually surrounded by birds. In the 2002 campaign a composition with 4x3 tiles was unearthed, showing a large trophy like high vase, with mascarons as handles, over a small pedestal surrounded by wide winding acanthus leaves and putti holding an element which would appear in other tiles.

SOME CONCLUSIONS

The decoration of each space within the convent will probably remain unknown to us due to the changes in the 19th century. What we can surely say is that a wide surface would be covered, and that specimens from different chronologies would be in use simultaneously, as happens in almost all spaces with such a long diachrony.

The lack of Hispano-Moresque tiles 16th-century tiles and the presence of *enxaquetado* tiles, and the two Spanish majolica tiles lead us to believe that the first tile covering was comprised of *enxaquetado* tiles, certainly a taste-based option, since other possibilities were available at the same time, and the community had the economic means to choose.

In the 17th century the convent was decorated with pattern tiles, punctuated by small evocative tiles depicting saints and religious imagery, which were still in place in the 19th century, when they were taken to Xabregas. Perhaps we can relate this redecoration with the convent's

expansion works that took place in the 1670's and 1680's, a period when blue on white tiles was becoming the norm.

The 18th century is the period from which the largest number of tiles was found, although we could only place together a small panel depicting Saint Barbara. The high number of frames would be connected to the purposeful removal of figurative panels in the late 19th century. Also from this period, we found a significant collection of single figure tiles, with different motifs, which would have been placed in less important spaces within the convent. Probably this perceived lack of importance and aesthetic value was the reason they were not taken to Xabregas.

Key-words: Lisbon' Convento Santana, Early Modern Archaeology, Pattern tiles; Figurative tiles

Lead glazed ceramics in Lisbon (16th-18th centuries)

Tânia Manuel Casimiro¹, José Pedro Henriques², Vanessa Filipe² and Carlos Boavida³

¹ IHC/IAP-FCSH, AAP, Lisbon, Portugal, tmcasimiro@fcsh.unl.pt

² IAP-FCSH/Cota 80.86, Lisbon, Portugal, jpedro.henriques@gmail.com

³ IAP-FCSH, AAP, Lisbon, Portugal, cmpboavida@gmail.com

SUMMARY

In 1572 the Lisbon Potters' Regulation divides the craft officials between redware, green glazed, white glazed and roof tile officials (*louça vermelha*, *louça verde vidrada*, *louça branca vidrada* and *telheiros*). This is one of the first documents in Lisbon mentioning the production of lead glazed wares. Older documents are known in other parts of the country such as in Coimbra where a 1556 regulation already mentions the production of lead glaze, calling the craftsman as *malagueiros*. Based on archaeological evidence the production and widespread consumption of Lisbon lead glaze may have started during the second half of the 15th century. In the Tagus valley area kilns producing lead glazes have been found at least in Alenquer, Mata da Machada and Santo António da Charneca.

The 1572 document, possibly not the first to be made but the one which survived, can in fact give us important information about craft organization and the importance of lead glaze production. The organization of the lead glazed potters is quite similar to the redware and tin glaze potters, electing two craftsmen as judges every year.

One of the main responsibilities of these judges was to examine who was able to become a lead glazed potter, who had to prepare the glaze, glaze the recipient and fire it, know how to use a small kiln in order to oxidize the lead and transform it into dust he also had to learn to grind and sieve the sand and add the right amount of copper oxide to give it a green colour. Although no yellow or brown glazes are mentioned in this document they are frequently found in Lisbon domestic environments and sometimes even associated to kiln wasters.

This document is also very specific concerning what type of objects the potters had to do in order to pass the exam: *alguidares grandes e pequenos* (large and small flared bowls), *frigideiras* (frying pans) and *tijellas de fogo* (cooking bowls), but also *panellas de mea arroba cada hua* (large boiling pans) *panellas mais pequenas e de toda a sorte* (smaller boiling pans) *almotolias grandes e pequenas* (large and small bottles), *tachos* (cooking pots) *enfusas de toda a sorte* (all types of jars) *pratos de toda a sorte* (all types of plates) *canos para telhados de cinco palmos* (pipes to be used in roofs), *malegas grandes que chamão vermelha* (large bowls), *escudelas de feição de porcelana* (bowls shaped as porcelain) and *hu servidor* (a pot which could have many functions including being used as a chamber pot).

The majority of these pots has a direct translation into the archaeological record and these were the shapes that Lisbon inhabitants were using when using lead glazed pottery in their daily activities.

The objective of this paper is to present the lead glaze artefacts found in two sites in the Lisbon area, one in Carnide (a 16th – 17th century dumpster) and the other in Rossio square (a 1755 house), and try to connect those shapes with the forms mentioned in the potters' regiment, discussing their use in the domestic activities of everyday lives.

The majority of the finds has the surface covered with green glaze. Could this be related to the availability of raw-materials? Was green glazed objects more resistant or was it just a tendency of Portuguese consumers to use such colour in objects?

Associating form with function is always a difficult task. Although the majority of recipients are easy to interpret and a cooking pot was destined to boil, fry or stew food, presenting different shapes, an *alguidar* was a multifunctional object and it is hard to specify what such objects were used for or what type of liquids were kept inside an *almotolia*. However, it is our objective to at least start a discussion on the importance that lead glazed objects had in the overall domestic consumption of lead glazed ceramics.

On the other hand, we should also try to understand how did people reacted to these objects. Were they seen exactly the same way as non-glazed objects? How did people felt when food was served or eaten in a yellow or green glazed bowl? Would they prefer it instead of a redware plate or bowl or even a tin glaze plate? All of these objects share the archaeological context thus all of them were used by the same population. What would make people prefer ones instead of the others? Would food look more appealing inside a yellow or a white plate? Would that make any difference at all?

The first major conclusion while analysing a late 16th /early 17th century context and comparing it to a mid-18th century household is that the consumption of lead glazes seems to intensively change during two centuries. While in the earlier context lead glaze is almost exclusively associated to table ware and small storage in the mid-18th century context the majority of the lead glaze ceramics is associated to kitchen ware with several cooking pots presenting an interior and sometimes exterior green glaze. Glazed objects continue to be used as tableware although lead glaze is clearly replaced by white tin glaze plates and, for the wealthier groups, porcelain.

When analysing numbers, we should also have in mind that each site corresponds to a specific social and economic background and not all of them can be interpreted the same way. Wealthy sites consume high quality products and the number of glazed wares, based in the available evidence seems to be higher in wealthier contexts, possibly indicating that these were more expensive than non-glazed objects.

Key-words: Pottery; lead glaze; green glaze, vessels; domestic consumption.

The 17th-century tile panorama in the island of Santiago, Cabo Verde: a first approach to a work in progress

Mariana Almeida^{1,2}

¹ *Instituto de Arqueologia e Paleociências da Universidade Nova de Lisboa (Portugal),*

² *Instituto de História Contemporânea da Universidade Nova de Lisboa (Portugal) and Doctoral fellow SFRH/BD/100982/2014 of the Fundação para a Ciência e Tecnologia (Portugal), Lisbon, Portugal, mariana.brit.almeida@gmail.com*

SUMMARY

Cabo Verde was part of the Portuguese Empire and, as such, the churches and other buildings were decorated accordingly, creating a unity of which tiles were a substantial part. Archaeological excavations in several sites in the island of Santiago have revealed a collection of tiles, most dated to the 17th century, which I discuss in this paper. Sites, decorations, chronology and function are presented, along with some preliminary conclusions stemming from the author's doctoral research on Portuguese tiles in Cabo Verde.

The aim of this paper is to present an overview of the 17th-century tiles found in the island of Santiago, Cabo Verde, from an archaeological point of view. The research presented here is part of a larger study conducted in the context of the author's doctoral thesis. As such, this is a preliminary exposition on the subject, with some considerations and suggested approaches for further development.

The 17th century marks the end of the prosperity and economic growth of Cabo Verde and Ribeira Grande in particular, but most buildings show pattern tiles dated to that century, which imply a certain degree of maintenance and investment in those infrastructures.

As for our knowledge today, there are seven sites in Santiago with this type of tiles: Rosário Church, Conceição Church, Cathedral of Ribeira Grande, Episcopal Palace, Nossa Senhora da Luz Church, São Francisco Convent and the Misericórdia Church. All these sites are located in Cidade Velha, except for Nossa Senhora da Luz Church, which stands in what was the settlement of Alcatrazes, the first head of Santiago's northern captaincy, created right after the colonization of the island and fell out of favour and was almost abandoned shortly after.

It is noteworthy that all buildings dealt with here are religious. The Church was, alongside the Crown, one of the few institutions powerful and wealthy enough to pay for the beautification of buildings. Yet it should be emphasised again that this may not constitute a reliable picture of tile consumption, as manor houses and non-religious buildings have not been extensively investigated.

Three other places have revealed 17th-century tiles through surveys and fortuitous finds. They are Alto do Salineiro, north of Cidade Velha, the stream course of Cidade Velha and the manor house which is now the Ethnographic Museum of Praia

18 different patterns were catalogued so far. There are no patterns exclusive to Cabo Verde. All specimens catalogued thus far have parallels in Portugal and some are, in fact, very common. This indicates that there was not a specific production of tiles for use outside Portugal, which likely translates an effort at uniformity among the colonies, where European settlers tried to maintain a European lifestyle.

There appears to be, however, a difference in distribution of patterns throughout the sites. The most common patterns, such as P-604 and F-13, are found everywhere, but most specific themes and decoration families seem to be found at only one site. The patterns recognised in Cabo Verde

are almost all very common. This lead us to believe that there was no specific tile production to be taken overseas. So far, we have not recognised special commissions, as seems happens in Madeira and Azores.

The overall quality of the tiles is standard when compared to what can be seen in Portuguese contexts. We find the usual glaze blisters, trivet and sagger pin marks, and few examples of over-firing, in typical proportions.

As regards provenance, all tiles seem to come from Lisbon, as they share the characteristics of that production centre. In fact, Lisbon was the largest producer of Portuguese tiles and faience, which were fired in the kilns and, most likely, made at the same workshops. Interestingly, this is also true of the other Atlantic islands (Azores and Madeira) and Brazil.

There is also the question whether there was a time lag in the application of patterns between Portugal and its colonies. It is particularly difficult to clarify this issue since each of the four decorative periods lasts for approximately twenty years. Interestingly, there are yet no designs from the first period (ca. 1600-1630), characterised by geometric caixilho compositions and simpler designs. Most patterns found in Cabo Verde fall within the second period (ca. 1630-1650), which sees a rise in creativity, with the corncob and camellia family of patterns (both of which we have been found on the island). The following period (ca. 1650-1680) sees a smaller number of patterns in Cabo Verde, possibly due to economic contraction, the decline in construction and the features of the tiles in this period itself, which sees new intricate and larger patterns, often with manganese, and altar fronts. Thus far, the fourth and last period (ca. 1680-1710) seems to be restricted to the cathedral, with blue and white only designs as a result of Dutch and Chinese influences.

It is also important to point out that there are tiles with other chronologies and typologies in Santiago, retrieved in the same excavations as the 17th-century tiles mentioned in this paper. There are *cuerda seca* and *arista* tiles from the 16th century, as well as 18th-century blue and white figurative tiles.

Key-words: Cabo Verde, 17th century

16th century azulejos - what lies beneath the ground of Lisbon?

Alexandre Pais¹, Maria José Sequeira², Maria de Jesus Monge³, Maria de Lurdes Esteves¹, Inês Castanheira⁴, António Valongo⁴, Cláudia Manso⁴, Victor Filipe⁵, Ana Margarida Cardoso⁶ and João Manuel Mimoso⁷

¹ Museu Nacional do Azulejo, Lisbon- Portugal, apais@mnazulejo.dgpc.pt,

² Direção Geral do Património Cultural, Lisbon,

³ Museu Biblioteca da Casa de Bragança, vila viçosa, Portugal,

⁴ Archaeologist, Lisbon,

⁵ Uniarq - Centro de Arqueologia da Universidade de Lisboa,

⁶ Laboratório HERCULES, Universidade de Évora

⁷ Laboratório Nacional de Engenharia Civil

SUMMARY

In the Vila Viçosa Palace, in the southern Portuguese province of Alentejo, lie the still impressive remains of what was the most extensive commission of azulejos produced in Antwerp for Portugal. In an inventory made in 1563 after the death of the 5th Duke of Braganza D. Teodósio, it was documented that no less than 3,658 azulejos commissioned to Antwerp had been delivered up to that year.

Until recently there was no known parallel between the pieces commissioned to Antwerp for the Palace of Vila Viçosa and other commissions for Portugal. At an excavation in Lisbon, in the area of the *Escolas Gerais* five azulejos and two fragments, also of Flemish production, were found (figure 1) in what is thought to be a rubbish tip because they were part of the frame of a panel of which nothing more was found.

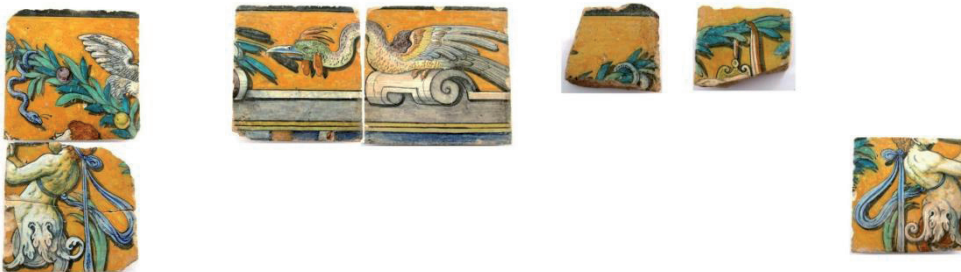


Figure 1a, b, c, d, e, f, g (clockwise left to right) – Azulejos and fragments found during an archaeological excavation in Lisbon, in the area of the old *Escolas Gerais*.

Other excavations in Lisbon, namely near Casa dos Bicos, Largo do Corpo Santo, Largo do Carmo, Palácio dos Condes de Penafiel and the grounds of the former Igreja de Santo André in Graça produced more fragments of 16th century azulejos of varying provenance giving us a glimpse of an unexpected wealth of types and decorations used in the Lisbon of the 2nd half of the 16th century at a time when a local production of faience azulejos was just starting. Now other pieces are now appearing in different archaeological contexts giving testimony of a discrete but nevertheless clear trend that needs to be acknowledged. The presence of these remains points to

the spread of an appreciation for faience tiles and may well be evidence of the foundation for the Portuguese taste for azulejos that has lasted to this day.

This communication reviews some of the findings supported by scanning electron microscopy observations and analysis which have tried to integrate some of these cases into known provenances or types.

Many excavations were carried-out in the past where the information has been lost as we can read in the 1872 testimony by Ribeiro Guimarães: “Mr. José Valentim (to whom we owe the preservation of the 16th century panel of *Nossa Senhora da Vida* that can be seen in the Museu Nacional do Azulejo) stated that at some excavations in the area of Olarias (in Lisbon) he found fragments of azulejos similar in production and painting, colours, etc, to those in the Chapel of Nossa Senhora da Vida. This incontestably demonstrates that in the 16th century the art of [majolica] production had already reached a level of perfection in Portugal” (*O Sr. Jose Valentim nos afirmou que, em umas escavações no sitio das Olarias, encontrara fragmentos de azulejos, eguaes na fabricação, e na pintura, cores, etc., aos da capella da Senhora da Vida. Este facto, que é incontroverso, mostra que no seculo XVI, estava em Portugal mui aperfeiçoada a arte de oleiro*) [1].

Well, we hope that many interesting azulejos, long lost in depots and archives of excavation finds, can still be dug out once again from their resting places and brought to light to be identified and studied in order to bring a more complete understanding of this exciting period of less than three decades that started a course of events that lead to the flourishing art of the azulejo in Portugal.

Key-words: Renaissance majolica; Faience tiles from Antwerp; Use of instrumental means in the study of majolica

ACKNOWLEDGEMENTS

Communication produced as an outcome of Project FCT-AzuRe - Estudos no Azulejo Português para Candidatura a Património da Humanidade (PTDC/EPH-PAT/5096/2014) funded by FCT, the Portuguese Foundation for Science and Technology.

LNEC Research Project 0202/111/19747

BIBLIOGRAPHIC REFERENCE

[1] GUIMARÃES, Ribeiro - *SUMMARIO DE VARIA HISTORIA. Narrativas, lendas, biographias, descrições de templos e monumentos, estatísticas, costumes civis, políticos e religiosos de outras eras*, Rolland & Semiond, Lisboa, 1872, vol. II, p. 107.

Conservation and restoration of the tile collection of Quinta Nova, Torres Vedras - Criteria and technique

Ricardo Triães¹, Ânia Chasqueira¹, Catarina Melo¹

¹ *Techn&Art - Technology, Restoration and Arts Enhancement Centre, IPT, Quinta do Contador, Estrada da Serra, 2300-313 Tomar, Portugal, rtriaes@ipt.pt*

SUMMARY

The work of recovering a vast collection of tiles from Quinta Nova, Torres Vedras, has been the subject of study and intervention of conservation and restoration in the Laboratory of Conservation and Restoration of the Polytechnic Institute of Tomar [1]. The collection is very diversified, both in stylistic terms and chronologically, being able to find pattern tiles of the 17th century, figurative tiles from the first half of the 18th century (figure 1), as well as pattern tiles of single figure and 'pombalinos'.

With the exception of a tile panel still in situ, but not in its original place, the remaining tiles were displaced, some in later reapplications, and the majority in boxes without any reference as to the place of provenance or position.

The fact that they have been removed without any care has caused huge problems for their conservation, since in addition to being a large collection and in need of triage and inventorying, there is also a very significant group of fragments.

So, the work developed consisted in the definition of an intervention methodology that allowed treating all the collection. The poor state of conservation of some of these elements has put a series of challenges that have led to the search for some creative solutions for its conservation. The methodology used was aimed at recovering the meaning as an image, although with very different results, both due to the state of conservation presented and the technique used. In the case of panels with gaps and lack of tiles was used the "hot" restoration technique [2]. For the tiles without any reference and for the fragments, a different methodology was followed, preserving them in a creative way [3], by juxtaposing the various elements according to a previously defined design, preserving their historical-artistic value but creating new readings (Figure 2, 3). These solutions are effective, in particular in how they conceptually address the problem of the conservation of very incomplete tiles, are compatible, reversible and still allow enjoying them.

Key-words: Tile, displaced heritage, creative conservation



Figure 1 – Figurative panel of Quinta Nova after intervention.



Figure 1 – Panel “tree”. Figure 9 – Panel of fragments "Tile of single figure".

BIBLIOGRAPHIC REFERENCES

¹ ESTEVES, Tânia - *Painel de azulejos da Quinta Nova, Tomar*. Relatório de estágio apresentado ao Instituto Politécnico de Tomar para obtenção do grau de Mestre em Conservação e Restauro. Tomar, IPT, 2011.

² ESTEVES, Lurdes e SILVA, Teresa - *O restauro de azulejos com fragmentos cerâmicos: uma técnica desenvolvida no Museu Nacional do Azulejo*, In *Actas do Azulejar*, Congresso Internacional, Aveiro e Ovar, 2012.

³ TRIÃES, Ricardo, FALCÃO, Cláudia e LOUREIRO, Leonor – *Conservação criativa, Edifícios e vestígios – Projecto-ensaio sobre espaços pós-industriais*. Inês Moreira (ed.), INCM, 2012, p. 216-223.

The earliest stencilled azulejos lining the façades of Lisbon

Joana Campelo¹, João Manuel Mimoso² and Alexandre Pais³

¹ *Laboratório José de Figueiredo, Lisbon, Portugal, joanacampelo@gmail.com*

² *Laboratório Nacional de Engenharia Civil, Lisbon, Portugal, jmimoso@lnec.pt*

³ *Museu Nacional do Azulejo, Lisbon, Portugal, apais@mnaz.dgpc.pt*

SUMMARY

The identification of the earliest Lisbon façades lined with semi-industrial azulejos was already attempted by us [1] as was the role, since 1840, of Fabrica Roseira in the first decades of their spread throughout the urban landscape [2]. In this communication we try and identify the earliest patterns used to line surfaces.

At this time (1840s to 1860s) when façades were lined with stencilled azulejos, three types of application could be considered, to which corresponded specific patterns according to the then extant aesthetic solutions:

- the surface-pattern tiles, used to line surfaces;
- the linearly patterned frame tiles, used to contour the architectural features where the azulejo lining terminated or was interrupted; and
- the freeze tiles under the cornice.

All the tiles were stencilled and at this early time, the frame tiles had the same dimensions as the surface liners - later they would be thinned to ca. 1/3 of the width of the “normal” tiles used to line surfaces [3]. Freezes, when used, had a height corresponding to two tiles and formed a linearly repeating pattern under the cornice.

An important early application of those tiles was on the walls of a bath house to treat mental disorders in a now abandoned Lisbon hospital (Figure 1). The bath house was inaugurated in 1853 and the lining is presumed to be contemporary because it is chronologically coherent with that year. In figure 1 two surface patterns, two frame patterns and one frieze are visible made of azulejos attributable to Fabrica Roseira.

The communication will review this and other examples from the 1840 to the 1860s elucidating the earliest patterns used on the façades of Lisbon.



Figure 1 – An aspect of the magnificent stencilled azulejos lining the walls of *Balneário D. Maria II* in Lisbon, over which was applied a plaque commemorating their inauguration by the Queen on October 29, 1853

Key-words: Portuguese azulejos; stencilled faience tiles; tiled façades of Lisbon.

ACKNOWLEDGEMENTS

Communication produced as an outcome of Project **FCT-AzuRe** - Estudos no Azulejo Português para Candidatura a Património da Humanidade (PTDC/EPH-PAT/5096/2014) funded by **FCT**, the Portuguese Foundation for Science and Technology.

LNEC Research Project 0202/111/19747.

BIBLIOGRAPHIC REFERENCES

- ¹ PAIS, A. et al. – *As primeiras fachadas azulejadas de Lisboa*, in Proc.Int. Cong. Azulejar, Universidade de Aveiro, 10-12 October 2012.
- ² MIMOSO, J-M. et al. – *An unlikely catalogue of the production of azulejos by Fábrica Roseira of Lisbon circa 1870*, in Proc. Int. Conf. GlazeArch2015, LNEC, Lisbon, 02-03 July 2015, pps. 81-90.
- ³ MIMOSO, J-M. – *Early façade azulejo frames by Fábrica Roseira of Lisbon*, in ARTISON-Special Issue Nr. 2, 2016, pps. 54-60.

Lookouts and outlooks: Lisbon, tiles and topography

Helena Cunha Lopes¹, Rui Matos¹ and Joaquim Marcelino Santos³

¹ Art History researcher, Municipal Council of Lisbon City, Portugal, helena.lobes@cm-lisboa.pt

² Art History researcher, Municipal Council of Lisbon City, Portugal, rui.matos@cm-lisboa.pt

³ Architect, PhD, Prof., Municipal Council of Lisbon City, Portugal, joaquim.santos@cm-lisboa.pt; Tampere University of Technology, Faculty of Architecture, Tampere, Finland; Lusíada University, Lisbon, Faculty of Architecture and Arts (UL); CITAD, Research Centre for Territory, Architecture and Design (UL)

SUMMARY

Reading cities and landscapes inform critical natural events that may characterize either environments. The hilly character of Lisbon demands an accurate sense of the natural versus the artificial, to reveal the natural environment under the metamorphosis of the human will.

The rehabilitation of the historical lookouts seems to be a task that must stem from other urban projects that are intrinsic to the city. Thereby, developing a contemporary image that frames past-present-future in the long continuum of artistic, architectural and urban heritage.

INTRODUCTION

The aesthetic experience of Lisbon implies certain degree of sensibility that focuses on tiles – *azulejos*. And tiles may perform remarkable differentiated rules regarding the intrinsic context that they form with the materiality of buildings, walls and spaces. *Azulejos* may behave as “ornamental cladding”, structural surface constructors, trompe l’oeil, ornament and last but not least, a fundamental framework for the city in which lookouts and their small, sensitive and intimate gardens play a strong role in order to portray the image of Lisbon.

The aim of this paper is to stress the importance of these essential lookouts from which the materiality of tiles is perceived together with other materialities, where the reflection of the Tagus mingles with the reflection of tiled surfaces, where colours meet. Recent rehabilitation of these public spaces establishes the importance of tiles afresh and motivates a reflection on the way the city shares its identity with the cultural identity of tiles. From white-blue to the polychromatic, Lisbon combines the revelation of tiles. This is only a particular layer of the city’s identity, with layers of the interiors of buildings that await other reflections.

LOOKOUTS AND METAMORPHOSIS ON TOPOGRAPHY

The aesthetics of environment as we experience and conceive today is particularly new and that would not come to a Greek, Roman or Renaissance mind. An the same seems true for the experience of the city scape. To experience the environment for aesthetic purposes alone is an idea that comes from the nineteenth century and meant a new approach to nature. Walking ten, twenty, forty kilometres within nature for aesthetic purposes would not come to an earlier mind. Furthermore, even for scholars, early experiences of nature meant acquaintance with the *geometrico-mathematization* of the *origo rerum* and thus *summa rerum* – we may emphasize – would have been a sign that rational mind may avoid.

The lookouts of Lisbon are, basically, cultural constructions and they illustrate that construction from a chronology of space and time. Perhaps, the most radical one is that embodies the most extended cultural construction itself is the Saint George Castle lookout – a perfect metamorphosis in space and time. The aim of terraces above the walls was not to fulfil an aesthetic requirement when they were built. They objectively represented safety, defence, functionality. Thus, from that early stage until the time when they became spaces of permanence to experience the whole

natural-artificially wide scale environment, aesthetically we needed to go through millennia. In this sense, a lookout of this kind roots Lisbon to early stages of classical civilization.

LAND-RIVER-SKY AND SEA

Places where sea and land meet have demonstrated to be landmarks of civilization. In this sense, there is an ancient character of Lisbon that is a cultural construction and yet common to other ancient civilizations and that character emanates directly from what its topography is in relation to the river and the ocean. Thus, all the lookouts combine land-river-sea. Even a lookout that does not access directly the river-sea does not break down the sense of immense dimension given by the huge extension of water up to the horizon and therefore lookouts are privileged places to a multidimensional experience of space-time. Yet any photograph or image, say such as that created in tiles, may actually embody that experience and thus we are telling about partial views that the artist or the photographer may emphasize.

We may believe that an artist such as Fred Kradolfer may have had a dilemma. On one hand Lisbon provides an overwhelming experience that is the point of departure of the artist himself and by another the artist has under his brush the power of the image. This problem also affects our judgements because we may discuss how far those tile panels are actual art works or, whether they are simply graphic means to achieve an end which is to guide us in an informative way rather in an aesthetic way.

Unlike architecture that has to pursue an end – to live in – art works such as painting and sculpture depend on image alone, they are self-sufficient, they are meant to be experienced insofar as they are an end in themselves, an image per excellence. Yet these panels seem to rely on a certain balance between a self-beauty – and thus they are aesthetically and artistically referable to art works such as paintings – and embody an ability to pursue a particular aim, that is to inform about what different buildings or places are, what their names are and how they relate to each other from that specific place of the lookout. Yet, in this latter sense they are not actual art works, or they have not been conceived as such.

THE PUBLIC RULE IN THE RESTORATION – A CULTURAL NEED

Lisbon lookouts are fundamental public spaces and therefore the role of the City of Lisbon is strategical in pursuing suitable uses as well as adequate strategies of rehabilitation of these places. And the presence of tiled panels maximizes the importance of requalification of these places where we experience both tiles and the city in a close and touchable way. We could stress, an intimate way that makes the aesthetic experience a vivid act.

The number of people, locals or tourists, that experience these lookouts is far higher than the number of people that enters museums, churches, or convents and thus, these places also work as vestibules to other comprehensive explorations of this art. There is a pedagogic context that goes beyond the given experience of these places. Consequently, the aim of the requalification as performed by the City of Lisbon stressed an overall rehabilitation of the lookouts.

CONCLUSION

Lisbon is a type of settlement that has roots in ancient strategies of changing the topography of the site. The historical walls of Lisbon are characteristic to that metamorphosis as well as all terraces that define the outlooks. We may trace back the origin of these sites to functional need of man but they seem to have acquired a single use which is fundamentally aesthetic to be in the place and to experience the cityscape alone. Thus, there is a new symbolic use nonetheless constructed in the ancient topography as well as in its metamorphosis whose materiality is often seen or felt. The presence of the ancient walls of Lisbon and of the castle is particularly important to this acquaintance with place.

As far as these sites are cultural constructions, the presence of tiles is of highly relevant importance. The tiles tell about a chronology of time that brings about an evolution of this art. Although it is not a comprehensive chronology its importance seems relevant not only by the fact that they return to the ability of creating a sense of interiority by the way how the space interacts reciprocally with them, but also because the panoramic panels may open a discussion to the evolution of Modern Art.

The importance of restauration held by the City of Lisbon and its public recognition is certainly a high contribution to the discussion of the perfect strategies of restoring tile panels as well to reflect on the new horizons that this art may embody in order to be recreated afresh. Last but not least, one should emphasize the rule of teamwork leading to the restoration of lookouts.

Key-words: Tiles, heritage, rehabilitation, lookout, Lisbon.

The use of modern azulejos and panels in Portuguese shop fronts

Catarina F. M. Geraldes^{1,2}, João Manuel Mimoso² and Alexandre Pais³

¹ *Departamento de Conservação e Restauro, Faculdade de Ciências e Tecnologia, Universidade NOVA de Lisboa, Caparica, Portugal*

² *Laboratório Nacional de Engenharia Civil (LNEC), Lisboa, Portugal; cgeraldes@lnec.pt*

³ *Museu Nacional do Azulejo, Lisboa, Portugal*

SUMMARY

There are several books [1-4] about the modern tiles (azulejos) in Portugal, often centring in well-known cases by renowned artists or more "spectacular" applications.

Spread throughout Portugal (and not only in Lisbon) there is also an important heritage of modern tiled shopfronts that are often neglected and therefore face silent destruction as the shops are passed on to new owners and different branches of business.

The close collaboration between Portuguese modern architects and artists resulted in appreciable benefits to the tiles of the modern period and certainly contributed to the resurgence of an artistic industry that was in decline before the 2nd World War. As discussed by the same authors [5] a particular case of azulejo integration includes those cases in which the lining at the ground floor is either the only one or significantly different from the rest of the building, often connected with a commercial purpose. Aesthetically speaking, these linings are important also because they are easily perceived, even in narrow streets, where the upper levels will go unnoticed. They are often, as well, creations that project or reflect the intention of an artist or a designer to transmit appreciative emotion

The case of shopfronts is singular in the fact that their design reflects the style of the time when the shop opened or was refurbished and, not that of the building itself, which may be much older. In the present work, all cases of modern shop fronts with integrated azulejo panels, either artist-designed or simply resulting from the application of pattern tiles, were considered from the point of view of a street walker. Some types of azulejos were identified: artistic azulejo panels or ceramic plaques, signed or unsigned; repetitive patterns; small Tijomel tiles; and flat or textured monochromatic azulejos. These were found in different localities: Lisboa, Porto, Torres Vedras, Torres Novas, Viseu, Beja and others.

Figure 1 shows an example in Lisbon, where the type used was designed by the well-known artist Maria Keil (1914-2012) [6] who personally identified tiles of the same pattern in the collections of the *Museu Nacional do Azulejo* as her own. However, as far as the authors know, this particular application was never mentioned in the literature.



Figure 1 – Rua da Portas de Santo Antão Nº 77, Lisbon

Integrated azulejos, new or old, must be valued as a national mark but they go often unnoticed possibly because “Portuguese eyes” are so very used to them. Although tiled façades are now protected, shop fronts are often forgotten because they only pertain to a small part of the façade. And they are at risk, not only because of the urban expansion but mostly because new shop owners refurbish the fronts often neglecting the tiles that went into the design of the previous avatars of that shop. If their preservation is not specifically assured, modern shopfronts will soon be a dimming memory of the past.

Key-words: Modern azulejos /shop fronts / modern decoration / Portuguese azulejos

ACKNOWLEDGMENTS

The authors acknowledge the Portuguese Science Foundation (FCT) for the funding of PhD grant PD/BD/114408/2016 (Catarina Geraldes) and Project FCT-AzuRe - Estudos no Azulejo Português para Candidatura a Património da Humanidade (PTDC/EPH-PAT/5096/2014) supporting this research.

BIBLIOGRAPHIC REFERENCES

- [1] SAPORITI, Teresa - *Azulejos de Lisboa do século XX*. No. of edition 437, Editor Porto: Afrontamento, Lisboa, 1992, ISBN 972-36-0199-0.
- [2] HENRIQUES, Paulo et al. - *O Azulejo em Portugal no século XX*. No. of edition ISBN 972.787.009.0, Editor Inapa, Lisboa, 2000.
- [3] SANTOS, Rui; PORFÍRIO, Luís; MECO, José - *Querubim Lapa Cerâmicas*. No. of edition ISBN 972-797-001-X, Editor Inapa, Lisboa, 2000.
- [4] ALMEIDA, Ana - *Da cidade ao Museu: uma proposta de itinerário pela azulejaria de autor na Lisboa da segunda metade do século XX*, Master dissertation, Lisbon University, 2009.
- [5] GERALDES, Catarina; PAIS, Alexandre; MIMOSO, João Manuel - *Aesthetics utility and values: a systematization of glazed ceramics in the façades of modernist architecture*, In: M. Menezes, D. R. Costa, J. D. Rodrigues (eds.) Congress Book Proceedings for the IPERION CH international conference - Intangibility Matters, Lisbon, 29-30 May 2017, pp 23-31.
- [6] [online] https://pt.wikipedia.org/wiki/Maria_Keil [Accessed 10 July 2018]

No Secret Beyond the Door: The Rampa store and its doorframe, a collaboration between Querubim Lapa and Conceição Silva, 1956

Rita Gomes Ferrão¹

¹ IHA-UNL – Instituto de História da Arte – Universidade Nova de Lisboa, Lisbon, Portugal, ceramicamodernistaemportugal@gmail.com

SUMMARY

In his American classic film noir “Secret Beyond the Door” (1947), German director Fritz Lang (1890-1976) introduced the symbolic concept of “felicitous room” developed by a character who is an architect that publishes a magazine on modern architecture, where he explores the thesis according to which the way a place is designed determines what happens in it, such as a certain church building where miracles usually happen.

Appropriating the concept of “felicitous room”, this paper intends to problematize the earlier collective work of Querubim Lapa (1925-2016) and Francisco da Conceição Silva (1922-1982), especially addressing the case of Rampa, a three floor store in the centre of Lisbon, designed in 1956, to sell fashion, art and design items.

Conceição Silva and Querubim Lapa are two key figures of the Modern Movement in Portugal. The first one is an architect and manager of multidisciplinary teams, promoting collaborations with artists and designers; the second is an artist and ceramist developing in situ work for architecture.

After World War II, architects and artists were involved in joint projects, with both commercial and social goals, striving to put art at the service of everyday life. In this context, the work of the Conceição Silva Studio is one of the most requested. The architect, known for his versatility and ability to boost artistic production, is responsible for designing a significant number of buildings, integrating the work of various artists.

Querubim Lapa, with a background in sculpture and painting, began his career in the 1940s, inside the Neo-Realist movement, later on becoming a main figure of Portuguese ceramics, famous for his murals and tiles.



Figure 1 – Armazéns do Minho (Minho’s department store), Angola, 1955. Photograph CEQL.

His work with Conceição Silva constitutes a paradigm, distinguishing itself as one of the most cohesive collaborative works between architects and artists of the Modern Movement. Starting with the designing of tile patterns for the delegation of Armazéns do Minho (Minho’s department store) (Figure 1), Moçâmedes, Angola (1955), this work evolved to the complex and innovative project of Rampa store (Figure 2) and went on.



Figure 2 – The Rampa store, Lisbon, 1956. Photograph Estúdio Novais, 1956, Calouste Gulbenkian Foundation.

Rampa's doorframe (Figure 3), a reinforced concrete structure covered with ceramic tiles designed and painted by Querubim Lapa, conceived to sustain an all-glass facade, became a key architectural element of the Modern Movement in Portugal, both in a historic and symbolic way. Telling the bustling story of Rampa, since it was built, during the golden period of its activity, until it was demolished and the doorframe apparently lost, will help us to understand the path of post-WWII Modernism in Portugal. The finding and recovery of this architectural element full of meaning, its public showing and the prospective integration in a public collection, ultimately will sustain the need to implement restoration and conservation processes, while promoting the renovation and reuse of buildings, especially considering the most permeable to seasonal trends, instead of destroying and musealize recovered fragments.



Figure 3 – The doorframe of the Rampa store. Photograph José Manuel Fernandes architect, 1980.

Key-words: Ceramic tiles, Querubim Lapa, Modern ceramic, Felicitous room, Modernism, Conceição Silva

Tracing the provenance of tin-glazed ceramics in the Netherlands

Luc Megens¹, Madelon Pronk^{1,2} and Simone Casale^{1,2}

¹ *Cultural Heritage Agency, Amsterdam, Netherlands, l.megens@cultureelerfgoed.nl*

² *Free University, Amsterdam, Netherlands*

SUMMARY

In the middle of the seventeenth century the Dutch Republic, and in particular the town of Delft, became famous for its Delftware production, tin glazed earthenware also known as maiolica or faience. “Hollandts porceleyn” or plateel, as the Dutch called it, was not only produced in Delft but also in several other cities in the Dutch Republic (Ostkamp¹). Before that, potters in the Republic already produced what is known in Dutch as majolica, cruder, thick bodied ceramics with a tin glaze only on the top or outside of the object. French and Italian as well as Portuguese faience was imported (Jaspers²) before migrating craftsmen brought the production technique was to the Dutch Republic.

Even when faience was produced by potters in the Republic, this type of ceramics was still imported as well (Jaspers²). It is not always easy to determine the origin of the ceramic just on morphological or stylistical grounds. A first study (Megens³) showed French and Dutch glazes could be distinguished by semi-quantitative non-invasive analysis with X-Ray Fluorescence Spectrometry (XRF). We extended this data-set with more faience objects attributed by archaeologists and faience specialists Nina Jaspers and Sebastiaan Ostkamp to Dutch, French, Italian and Portuguese production centres. The glaze analysis results were also compared to the outcome of analysis of the ceramic body by XRF and Scanning Electron Microscopy with Energy Dispersive X-Ray Analysis (SEM-EDX).

MAIN RESULTS AND CONCLUSIONS

The plot of the SnK α : PbL α ratio against the Rayleigh normalized PbL α intensity of the dataset of faience from various excavations in the Netherlands is shown in fig. 1. There appears to be considerable overlap between the provenance groups. Part of the measurements of “Dutch” objects cluster with the “French” or the “Portuguese/Italian” measurements belong mostly to objects that are attributed to the workshops of Gerrit and Willem Verstraeten in the Dutch town of Haarlem. Also the Portuguese and Italian groups overlap, while even some measurements of allegedly Portuguese or Italian objects fall in the main group of Dutch faience. PCA analysis of all the variables in the dataset, however, shows a rather clear separation between the Portuguese and Italian groups.

PCA analysis of the XRF measurements of the ceramic body shows a well-defined Italian group. The Verstraeten objects were not included in these measurements so it is not clear if they would cluster with the Italian measurements. Portuguese and Dutch products seem quite different, but both have overlap with the French group.

The results show that non-destructive XRF analysis of the glaze gives a good indication of the provenance of faience, important for the investigation of museum objects. Combining these results with analysis of the ceramic body can attribute to a more certain determination of the provenance.

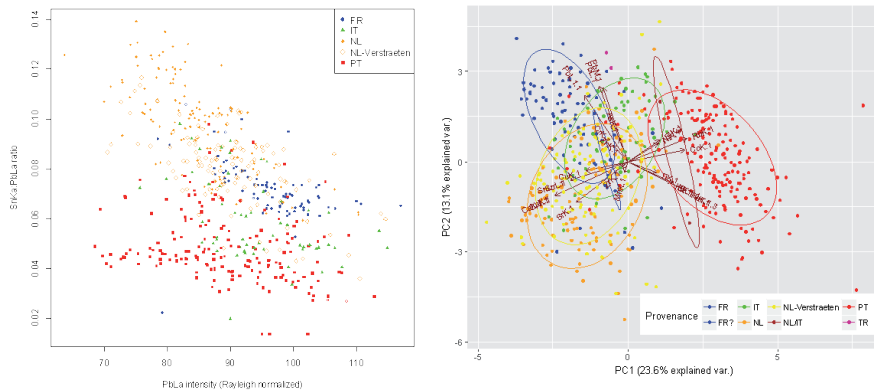


Figure 1 – Left: Plot of the ratio of the intensities of the SnK α to the PbL α peak against the intensity of the PbL α peak normalized to the RhK α Rayleigh scatter of white areas of faience glazes. Right: plot of the first two principal components after PCA on the entire dataset of white glaze measurements (calculated with the prcomp function in r).

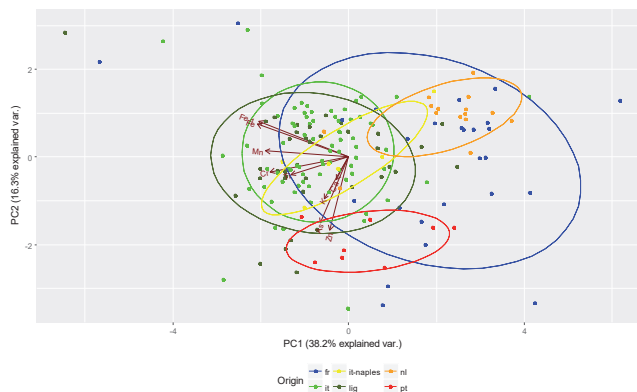


Figure 2 – Plot of the first two principal components of the XRF analysis of the ceramic body.

Key-words: Tin-glazed ceramics, provenance.

BIBLIOGRAPHIC REFERENCES

- [1] Ostkamp, Sebastiaan – *White Delft as part of the range of faience produced in the Dutch Republic of the seventeenth and eighteenth century*. In: Eliens, Titus, *White Delft, Not just Blue*. Waanders Uitgevers / Gemeentemuseum Den Haag, The Hague, 2013, 77 – 123.
- [2] Jaspers, N. – *Cream from the Milkmaid. Plain white faience of foreign origin excavated in the Netherlands (1500-1680)*. In: Eliens, 2013, 45 - 76.
- [3] Megens, Luc and Verhaar, Guus – *Determining the origins of tin-glazed earthenware through chemical glaze analysis*. In: Eliens, 2013, 149 - 161.

A new 15th-16th century pottery kiln on the Tagus basin, Alenquer, Portugal

L.F. Vieira Ferreira¹, I. Ferreira Machado^{1,2}, T. M. Casimiro³

¹ CQFM-Centro de Química-Física Molecular and IN-Institute for Nanosciences and Nanotechnologies and IBB-Institute for Bioengineering and Biosciences, Instituto Superior Técnico, Univ. de Lisboa, Lisboa, Portugal, luisfilipevf@tecnico.ulisboa.pt

² Polytechnic Institute of Portalegre, P-7300-110 Portalegre, Portugal. ilferreiramachado@tecnico.ulisboa.pt

³ Instituto de História Contemporânea e Instituto de Arqueologia e Paleociências da Universidade Nova de Lisboa. Departamento de História, Lisboa, Portugal. tania.casimiro@tecnico.ulisboa.pt

SUMMARY

A detailed archaeometric study of pottery was made of a 15th-16th centuries kiln located inside the walls of the Castle of Alenquer. The locally collected sherds are lead glazed, and most exhibit a green or dark yellow decoration. In one case, a fragment of a bowl has two different coloured glazes, green on the exterior and white on the interior. Tin oxide was detected in the white glaze. The samples were studied with the use of non-invasive or quasi non-invasive techniques. Ceramic bodies from the pottery produced in the Alenquer kiln were characterized in terms of their mineralogical and elemental composition. This pottery was fired twice, the first time at high temperatures to produce the biscotto, and the second time at lower temperatures to glaze the ceramics. Although only one type of raw material collected locally was used, two types of the resulting ceramic bodies were detected and organized into two Groups: one produced at about 850°C, another at about 950°C.



Figure 1 – Three representative samples from Alenquer kiln.

Ceramic bodies from Group 1 are converted into Group 2 ceramic bodies whenever the temperature of the kiln is raised from 850°C to 950°C, as we observed by firing the ceramic bodies from the Group 1 in our laboratory. Dark yellow colour was assigned to chromophore $\text{Fe}^{3+}\text{O}_3\text{S}^{2-}$ detected by ground state diffuse reflectance absorption spectra.

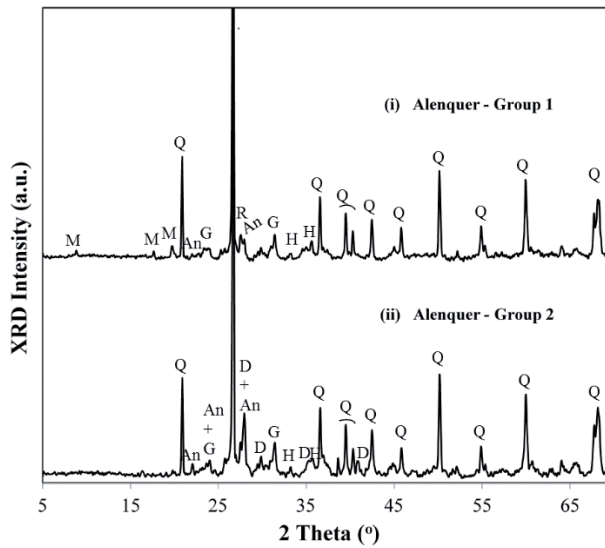


Figure 2 – Representative XRD patterns for ceramic bodies from Alenquer sherds: (i) Type 1; (ii) Type 2. The XRD peaks are assigned to: Quartz (Q), Diopside (D), Gehlenite (G), Anorthite (An), Hematite (H), and M (Muscovite).

These results were compared with those obtained for coeval ceramics produced in Portugal, namely at Santo António da Charneca and Mata da Machada. Both kilns were located close to Lisbon, on the south shore of the river Tagus, as previously reported [1-2]. It is now possible to clearly distinguish the productions of three of the major production areas in the Tagus Valley, information which will be very useful in future studies to understand the distribution patterns of these three kiln areas not only in the Tagus area but also in a wider regional basis and how production characteristics may have influenced consumer choices.

Key-words: Pottery, μ -Raman spectroscopy, Diffuse Reflectance Absorption Spectroscopy, X-Ray Fluorescence Spectroscopy, Diffractograms.

BIBLIOGRAPHIC REFERENCES

- [1] L.F. Vieira Ferreira, D.S. Conceição, D.P. Ferreira, L.F. Santos, T.M. Casimiro, I. Ferreira Machado, Portuguese 16th century tiles from Santo António da Charneca's kiln: a spectroscopic characterization of pigments, glazes and pastes. *J. Raman Spectrosc.* 45, 838-847 (2014).
- [2] L.F. Vieira Ferreira, A. Gonzalez, M.F.C. Pereira, L.F. Santos, L.F., T.M. Casimiro, D.P. Ferreira, D.S. Conceição, I. Ferreira Machado, Spectroscopy of 16th century Portuguese tin-glazed earthenware produced in the region of Lisbon. *Ceram. Int.* 41,13433-13446 (2015).

Beneath sacred land: glazed pottery from the old Church of La Concepción in Zamora

Uxue Sanchez-Garmendia¹, Estefania Calparsoro², Gorka Arana³ and Javier G. Iñáñez²

¹ Department of Analytical Chemistry, Faculty of Science and Technology, GPAC, Built Heritage Research Group, University of the Basque Country UPV/EHU, Bilbao, Basque Country, Spain, e-mail: uxue.sanchez@ehu.eus

² GPAC, Built Heritage Research Group, Faculty of Arts, University of the Basque Country UPV/EHU, Vitoria-Gasteiz, Basque Country, Spain

³ Department of Analytical Chemistry, Faculty of Science and Technology, University of the Basque Country UPV/EHU, Bilbao, Basque Country, Spain

SUMMARY

A set of 14 archaeological ceramics, including tin-lead glazed, micaceous and “Duque de la Victoria” type ceramics, from 15th-16th centuries recovered from the rests of the goldsmithing workshop beneath the Church of La Concepción (Zamora, Spain) was archaeometrically characterized by Inductively Coupled Plasma Mass Spectrometry (ICP-MS), X-ray Diffraction (XRD) and Scanning Electron Microscopy (SEM). Ceramic provenance has been established as being mainly from local origin with some examples from other regional production centers.

INTRODUCTION

During the past two decades, numerous excavations have been conducted in the city of Zamora: two were carried out at the places corresponding nowadays to the Provincial Historical Archive and the Public Library of the State, another at the Ethnographic Museum and the last at the area known as Olivares. In the same site, where nowadays lies the Provincial Historical Archive, there was an old convent called *Convento de Nuestra Señora de La Concepción*, while in the adjacent plot, where the Public Library of the State was constructed, there was the church known as *Iglesia de Nuestra Señora de La Concepción*. Archaeological works shed light on the existence of evidences from earlier dates beneath the church. On the one hand, numerous holes stuffed with medieval hispanomuslim ceramics from the ages and dated before the 13th century were documented; and on the other hand, evidences of a goldsmithing workshop that was active between 13th and 16th centuries were also found. In the course of these fieldworks an important set of archaeological materials, including an important set of ceramics, has been recovered. Regarding the purpose of this work, it not only is to characterize the pottery from the archaeological site of the Church of La Concepción and the prior goldsmithing workshop, but also to assess the provenance of local or regional origin of the ceramics, shedding light on the regional trade and local consumption patterns.

ANALYTICAL METHODOLOGY

A set of 14 archaeological ceramics, including tin-lead glazed, micaceous and *Duque de la Victoria* type ceramics from 15th-16th centuries recovered from the remains of the goldsmithing workshop beneath the Church of La Concepción (Zamora, Spain) was archaeometrically characterized. Among them, 7 are tin-lead glazed ceramics: 2 are decorated with blue motives, one with green and brown and the last one with black and green motives. Another 6 are micaceous, and the last one is a fragment of *Duque de la Victoria* type. Ceramics were analyzed by means of Inductively Coupled Plasma Mass Spectrometry (ICP-MS), X-ray Diffraction (XRD) and Scanning Electron Microscopy (SEM).

RESULTS AND DISCUSSION

The results of the chemical analysis (ICP-MS) have been graphically displayed (Hierarchical Cluster Analysis, HCA). Examination of the resulting dendrogram shows a clear 4-group structure that corresponds to the different productions identified in La Concepción and the Olivares productions already established. Interestingly, all of the tin-lead glazed ceramics unearthed at the Church of La Concepción show a chemical fingerprint compatible with the already identified Z-3 group from Olivares workshops. Furthermore, another set of ceramics has been identified as Z-4. This group is formed by 4 micaceous ceramics. All of them are unglazed and are, basically, cooking pots and serving vessels. The dendrogram also reveals the existence of three ceramics that do not match any of the paste reference groups identified in the city of Zamora. Along these lines, ZMR037 and ZMR039 are of micaceous paste and, surprisingly, do not cluster together with Z-4 group that is also micaceous. Likely, this two ceramics belong to another ceramic production from the renowned vicinity potting villages in the region, like Pererueta or Muelas del Pan. Finally, ZMR050 is also not linked to any of the already established chemical groups in Zamora due to higher values mainly on Al_2O_3 , Ba, Ce, Cr, La and Fe_2O_3 , as well as much lower CaO amounts.

Mineralogically, exactly 50% of the ceramics are calcareous, showing more than 13% of CaO content in most of the cases. Besides, all the calcareous ceramics are from the Z-3 chemical group, defined in the study about the workshop of Olivares. Along these lines, in this latter study, four different fabrics were identified for Z-3 (F-I, F-II, F-III and F-VI). Thus, among the calcareous ceramics from the Church of La Concepción, some belong to the fabric F-II, while the rest of the ceramics define two new fabrics (F-IV and F-V). On the one hand, typical calcareous earthenware phase associations are identified in Z-3. The main mineral phases that form the Z-3 ceramics are quartz, potassium feldspar, gehlenite and calcite. The Equivalent Firing Temperature (EFT) ranges between 850 °C-1000 °C for these fabrics.

The chemical group Z-4 is formed by four micaceous ceramics. In this group, two different mineralogical fabrics have been identified: F-Ia and F-Ib, and F-II. Main mineralogical phases identified are quartz, potassium feldspar and illite. EFT ranges between 800 °C-900 °C for these fabrics.

Furthermore, the rest two micaceous sherds and *Duque de la Victoria* type one, do not belong to any specific chemical group. When it comes to the two micaceous ceramics, they have the same phase associations as the F-I from Z-4 with an EFT in the range of 800-850 °C. Finally, *Duque de la Victoria* type ceramic contains quartz, potassium feldspar, plagioclase and illite, providing an EFT around 850 °C.

After chemical and mineralogical analyses, 4 glazed ceramics were selected for SEM-EDS study in order to deepen into the understanding of their glaze composition and pigment nature. According to SEM-EDS results of the glazed ceramics, all of the glazes analyzed are Pb and Si based. In addition, SEM-EDS enables for identifying Sn particles distributed thoroughly within the glaze. These crystals are likely cassiterite (SnO_2) and, along with some relicts of quartz and sometimes feldspars, help out for achieving the opaque white colour diffracting and dispersing the incident light. Regarding the blue decoration, this one was achieved by the use of Co and Fe. Interestingly, in the blue areas of the Zamoran ceramics, Co-Fe particles are found under the glaze and directly in contact with the clay body. Besides, Cu content has been found in green areas by SEM-EDS. Finally, Mn compounds are unequivocally the responsible for obtaining brown and black colours. Thus, these Mn particles can be found as mainly Mn particles or as Mn-Si-Pb particles.

CONCLUSION

This study has deepened into the understanding of the pottery consumption in Zamora during Late Medieval and Early Modern periods after the archaeometrical characterization of pottery unearthed in the Church of La Concepción. Thus, chemical analysis has enabled the identification of two reference groups: on the one hand, tin-lead glazed pottery from this site is chemically compatible with the already established Z-3 local reference group from the Olivares workshop, and on the other hand, one new chemical group has been identified, Z-4. This group is formed uniquely by micaceous unglazed ceramics, although its local origin cannot be surely proposed given the state of archaeometrical knowledge up to date. Then, a regional Zamoran provenance should be highly taken into consideration as well. Unfortunately, two micaceous ceramics could not be assigned to any of the known chemical reference groups. In addition, one ceramic archaeologically described as *Duque de la Victoria* type from Valladolid, could not be either assigned to the known groups, so its provenance remains unclear.

Technologically, tin-lead glazed ceramics from Zamora at this chronological period are calcareous and show creamy colour pastes, being fired at temperatures ranging from 850 °C to 100 °C in oxidizing conditions. Additionally, most of the micaceous ceramics show a relatively low firing temperature, from 800 °C to 850 °C, while just one example reaches an EFT of 900 °C.

Besides, SEM-EDS analyses have facilitated the identification of the nature of the different pigments employed by Zamoran potters for decorating their ceramics following traditional hispanomoresque contemporary recipes. Thus, white opaque coatings were achieved by the use of SnO₂ in the Si-Pb glaze. Moreover, green colour is obtained by the addition of Cu compounds, while the brown/black pigment is obtained by the use of Mn ones. Interestingly, the nature of blue pigment is related to the use of Co and Fe particles, which seem to be applied under the glaze coating.

In agreement with the archaeometrical results of this study, the consumption of pottery by the people who inhabited and work in the goldsmithing workshop during the 15th and early 16th centuries show a local pattern. In this way, the use of local Zamoran ceramics, as well as micaceous ceramics from regional contexts, is predominant in this site. Therefore, and given the initial results presented, a long-distance trade cannot be excluded, although it is not reinforced by the archaeometrical results of the sample studied so far.

Key-words: Pottery, glaze, chemical analysis, mineralogical analysis, post-medieval

Villafeliche, an 18th century majolica producing village in the heart of Aragon (Spain)

Javier G. Iñáñez¹

¹ University of the Basque Country (UPV/EHU), Vitoria-Gasteiz, Spain, javier.inanez@ehu.eus

SUMMARY

By the sixteenth century, Spanish majolica production flourished as Italian-influenced decorative styles diffused into the Iberian Peninsula. Aragonese majolica also was influenced by the new Italian-influenced decorative trends and styles. Consequently, black and especially green motifs—colors associated with Islamic ceramic traditions—were progressively replaced by blue patterns, sometimes mixed with other colors, such as yellow. In contrast, however, Aragonese potters combined traditional hispanomoresque motifs, with the new Renaissance influences. This fusion of decorative elements resulted in a distinctive ceramic product. From the sixteenth century until the end of the eighteenth century, the town of Muel and Villafeliche afterwards, became the main production centers in the region of Aragon along with Teruel. Although lusterware production was very important during fifteenth and sixteenth centuries in Muel, tin lead glazed pottery decorated with blue on white motifs made in Muel and Villafeliche achieved a relevant impact on Renaissance Spain¹. The production of tin lead glazed ceramic in Villafeliche can be chronologically established during the 15th century, and was strongly linked to the hispanomoresque population. Villafeliche, along with Muel and Teruel, is one of the main majolica production centers of the Iberian Peninsula. The technical and artistical quality achieved by the ceramists from Villafeliche provided the village with wide recognition, especially regarding the blue and polychrome tin lead glazed ceramics.

According to historical written records, the village of Villafeliche belonged to the Camarassa marquis, who expanded the city walled limits with the establishment of new workshops in early Modern era. These new artisan areas received the name of Herrerías (blacksmiths) and Ollerías (pottery workshops) neighborhoods, amongst others². In this way, in a document dated to 1575, a potter appears in a wedding contract, evidencing the ceramic activity in Villafeliche. Furthermore, the Camarassa marquis rented some properties to a neighbor from the nearby Monton village, providing historians with a very detailed description of the neighborhoods and main work activities in Villafeliche, including pottery making. Interestingly, this demonstrates that the pottery workshops and ceramic activity in Villafeliche was kept intact even after the expulsion of the Moresque population in 1609-1614, which was Muslim population converted into Christians by law, although most of them managed to keep some of their cultural and religious idiosyncrasy². In addition, new potters were established into the village, according to written documents. Along these lines, names like “Jaime Villar, *cantarero* (jar making)” in 1623, or Pablo Pasqual, *escudiller* (porringer maker) in 1626, appear as doing transactions with traders or as house owners². Besides, the ceramic activity of the village is clearly linked to the production of black powder, which both showed a growing pulse since late 17th century and during the whole 18th century. However, in the 19th century, tin lead glazed production seems to clearly decreasing and, already at the beginning of the 20th century, it has completely ceased.

In order to shed light to the ceramic productions from Villafeliche, a sample of 21 ceramics obtained from the Museu de la Ceràmica de Barcelona collection was obtained. All the ceramics analyzed were tin lead glazed pottery with blue on white motifs and dated back to the 18th century. These ceramics were unearthed in the context of the archaeological surveys conducted by Llubíà during the mid-20th century in the ceramic dumps of Villafeliche, specifically in the workshop area known as “Los Portillos”. Thus, the ceramics that compose this study are considered of local

origin given its precedence of a ceramic dump and the fact that the sample also includes kiln furniture, such as spurs, as well as discarded ceramics or failures.

During statistical treatment, chemical variables have been transformed into logarithm ratios following the aforementioned methodologies from the following subcomposition: Fe_2O_3 , Al_2O_3 , MnO , TiO_2 , MgO , CaO , SiO_2 , Ba, Zn, Sr, Ce, V, Ni and Cr, using Nb as divisor since it is the less variable amongst the dataset, according to the calculated variation matrix³. The variation matrix obtained shows a total variation (vt) of 0.214, which enables to suggest a monogenetic grouping³. The elements responsible for the highest variation amongst the dataset are, mainly, MgO , CaO , Na_2O , K_2O , Sr, Ce and Cu ($\text{vt}/\tau.i < 0.6$). Besides, MJ0068 shows a high variation due, mainly, to its very high CaO content (23.71%). Therefore, when calculating a new compositional variation matrix without considering those elements that are susceptible of being altered (Na_2O , K_2O and Cu), the vt is only of 0.098, which is clearly an indication of a very compact chemical group³.

Results can be summarized in the dendrogram obtained after the clustering analysis of the latter subcomposition using the Euclidian squared distance and the centroid agglomerative method. The study of the dendrogram enables determining a single homogeneous structure clearly different to the rest of Spanish productions and showing fusions between individuals at very low ultrametric distance (< 0.05 units). Dissimilarities between individuals are mainly due to slight differences in Zr, Ba and Ce, having the ceramics on the left of the dendrogram a more abundant clayey phase than the ceramics on the right of the dendrogram, which show higher Zr amounts related to more sandy phases. The individual MJ0068 merges with the rest of the ceramics at a higher ultrametric distance (0.15 units), mainly due to its higher CaO amounts (23.71%), while the mean of CaO for the Villafeliche ceramics is 17.39%. Therefore, the small differences observed between ceramics should not be due to differences in productions or recipes but most likely, to the fact that these productions are pre-industrial processes. Thus, 18th century potters used standardized recipes but showing slight differences due to small geochemical differences within the clay pits and later processing, supported by archaeological data.

Mineralogically, Villafeliche ceramics show typical calcareous earthenware phase associations, similar to the ones already described for the reference groups of modern-era Spain⁴. Thus, quartz, plagioclase (mainly anortite), diopside and gehlenite, sometimes also calcite, are the main mineral phases, providing an estimated firing temperature (EFT) around 950-1000 °C. However, it is important to highlight the presence of analcime in some of the ceramics, a sodium zeolite [$\text{NaAlSi}_2\text{O}_6 \cdot \text{H}_2\text{O}$]. Analcime forms a solid solution with wairakite [$\text{Ca}(\text{Al}_2\text{Si}_4)\text{O}_{12} \cdot 2\text{H}_2\text{O}$]. Given the presence of high calcareous ceramics fired at temperatures around or over 1000 °C, analcime is suggested as a secondary phase, likely related to the alteration of the vitreous phase of the clay matrix and the posterior crystallization of this zeolite likely as a by-product of gehlenite decomposition under postdepositional conditions⁵. After SEM examination, and according to the low crystallization of new crystallites within the interphase between clay paste and glaze, the ceramics were manufactured by a two-firing process technology. Thus, a first firing to obtain the bisque ceramic, reaching the temperatures of 950-1000 °C as seen by XRD analysis, and a second firing for the application of the glaze, likely reaching lower temperatures in the kiln.

The archaeometrical results enable linking the ceramics unearthed in Villafeliche to a local origin related to the ceramic productions during the 18th centuries, in agreement with the archaeological record. Thus, the production of the 18th century keeps the tradition of employing calcareous clays that is observed in previous local productions, as well as the use of tin lead glaze recipes for glazed coatings.

Key-words: Majolica, postmedieval, XRF, XRD, SEM

ACKNOWLEDGMENTS

J.G. Iñáñez thanks the Spanish Ministry of Economy and Competitiveness for a Ramon y Cajal contract (RYC-2014-16835). The ongoing investigation in which this work is framed has received funding from the Spanish Ministry of Economy and Competitiveness CERANOR-2 (HAR2017-84219-P).

BIBLIOGRAPHIC REFERENCE

- ¹ ÁLVARO-ZAMORA, M.I., 1997. *Cerámica Aragonesa*, in: Sánchez-Pacheco, T. (Ed.), *Cerámica Española*. Summa Artis, Espasa Calpe, Madrid, pp. 221–288.
- ² ÁLVARO-ZAMORA, M.I., 2003. *Cerámica Aragonesa*. Ibercaja, Zaragoza.
- ³ BUXEDA I GARRIGÓS, J., KILIKOGLU, V., 2003. *Total variation as a measure of variability in chemical data sets*, in: van Zelst, L. (Ed.), *Patterns and Process. A Festschrift in Honor of Dr. Edward V. Sayre*. Smithsonian Center for Materials Research and Education, Suitland, Maryland, pp. 185–198.
- ⁴ IÑÁÑEZ, J.G., 2007. *Caracterització arqueomètrica de la ceràmica vidrada decorada de la Baixa Edat Mitjana al Renaixement dels principals centres productors de la Península Ibèrica*, 205107th–11th ed. Universitat de Barcelona, Barcelona.
- ⁵ SCHWEDT, A., MOMMSEN, H., ZACHARIAS, N., BUXEDA I GARRIGÓS, J., 2006. *Analcime crystallization and compositional profiles - Comparing approaches to detect post-depositional alterations in archaeological pottery*. *Archaeometry* 48, 237–251.

SEM-EDS research on mineral inclusions found in the biscuit of azulejos as a tool for provenance studies

João Manuel Mimoso¹, Dória Rodrigues Costa¹, Maria Augusta Antunes¹, Ana Margarida Cardos², Lurdes Esteves³, José Mirão² and Alexandre Pais³

¹ *Laboratório Nacional de Engenharia Civil, Lisboa- Portugal, jmmimoso@lnec.pt*

² *Laboratório HERCULES- Universidade de Évora, Évora - Portugal*

³ *Museu Nacional do Azulejo, Lisboa- Portugal*

SUMMARY

Since 2016, the *Museu Nacional do Azulejo* (Portuguese National Azulejo Museum), the *Laboratório Nacional de Engenharia Civil* and the HERCULES Laboratory of the University of Evora made a joint effort in the instrumental study of 16th century Portuguese azulejos, aimed at establishing their origin, technology and eventual systematization of workshop productions. The microscopic observation of the biscuits did not hint obviously to widespread mixtures of clays, as are routinely observed in the sections of 17th century azulejos. Therefore, it seems likely that the workshops often used plain marls with a suitable composition to grant compatibility of the biscuit with the glaze and thus their composition is a prime choice to confirm a local provenance.

Azulejo samples are collected from panels on the walls and consequently are necessarily superficial and very small. In such samples the biscuit composition as pertains to minor and trace elements is tainted by the penetration of the raw glaze and digestion phenomena over firing. However inclusions of minerals that are infusible at the kiln temperatures remain largely unaltered. A means to discriminate provenance of azulejos based on a morphologic and compositional study of the small inclusions found in biscuit sections, often less than 5 μ m across, is proposed in this communication. These include mineral inclusions, both with and without repetitive morphologies (figures 1 and 2), and micro-fossils.

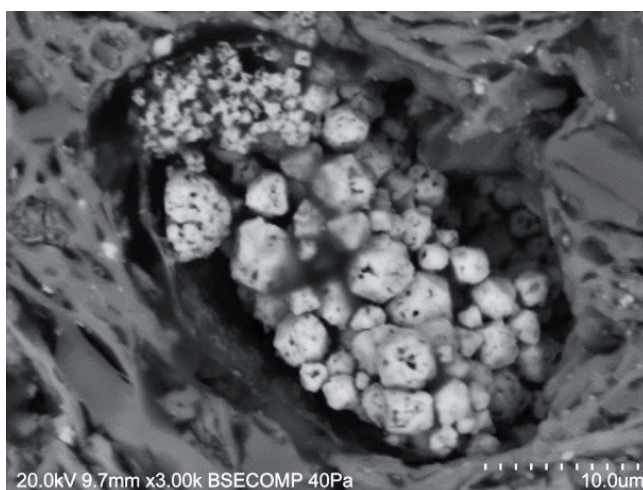


Figure 1 – Irregular frambooid associated with large euhedral crystals (Az 032/07)

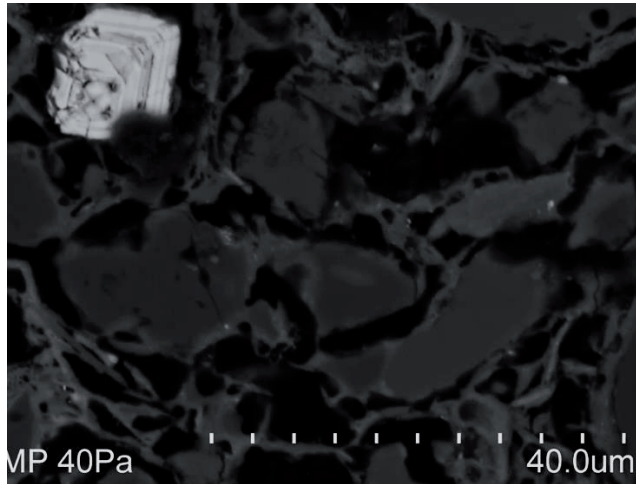


Figure 2 – BSE image of a zircon crystal with inner growth marks apparent (Az068/06)

This communication reviews the inclusions repetitively found in Portuguese 16th century azulejos as a first step for the construction of a database aimed at exploring their potential as markers of provenance.

Key-words: Provenance of ceramics; Early azulejo production in Lisbon; Use of SEM-EDS in the study of majolica; mineral inclusions in ceramics.

ACKNOWLEDGEMENTS

Communication produced as an outcome of Project FCT-AzuRe - Estudos no Azulejo Português para Candidatura a Património da Humanidade (PTDC/EPH-PAT/5096/2014) funded by FCT, the Portuguese Foundation for Science and Technology.

LNEC Research Project 0202/111/19747.

Underglaze-decorated tin-opacified tiles from the 15th-16th-century Iberian Peninsula

Susana Coentro¹, Luís C. Alves², Jaime Coll Conesa³, Teresa Ferreira⁴, José Mirão⁵, Rui C. da Silva⁶, Rui Trindade⁷ and Solange Muralha¹

¹ VICARTE – FCT-UNL, Caparica, Portugal, susanacoentro@gmail.com

² C2TN, Campus Tecnológico e Nuclear, IST-UL, Bobadela, Portugal

³ Museo Nacional de Cerámica y Artes Suntuarias “González Martí”, Valencia, España

⁴ Dep. Química, ECT, Laboratório HERCULES, Universidade de Évora, Portugal

⁵ Dep. Geociências, ECT, Laboratório HERCULES, Universidade de Évora, Portugal

⁶ IPFN, Campus Tecnológico e Nuclear, IST-UL, Bobadela, Portugal

⁷ Museu Nacional de Arte Antiga (MNAA), Lisboa, Portugal

SUMMARY

The Islamic presence in the Iberian Peninsula between the 8th and the 15th centuries provided a specific background for the development of important ceramic centres. Among the most important innovations brought by the Islamic potters were the tin-opacified glazes and the cobalt blue pigment [1]. Archaeological evidence has shown that in Valencian blue-and-white or blue-and-lustre ceramics, an underglaze painting technique was used: the cobalt pigment was applied onto the raw ceramic object, which was then fired for the first time; then, the white lead-tin glaze frit was applied to cover the object's surface, and the ceramic object was fired a second time [2]. Besides Valencia [3], an underglaze tin-opacified cobalt blue decoration has also been documented in Teruel [4] and Seville [5].

The Valencian and Sevillian regions were among the most important production centres of Hispano-Moresque ceramics. While in Valencia the underglaze technique was the most used one for decorating ceramic tiles, in Seville the *cuerda seca* and the *arista* techniques were more popular [1]. Nevertheless, during a recent study on Hispano-Moresque tiles [6], an underglaze decoration was identified in shards attributed to a Sevillian production. Opposing to what has been written about Valencia, underglaze-decorated Sevillian ceramics were yet to be studied. This study characterises and compares tin-opacified underglaze-decorated tiles from these two different provenances.

A group of 14 tiles from three different institutions – Monastery of Santa Clara-a-Velha, Coimbra, Portugal (SCV); Museo de Cerámica “González Martí”, Valencia, Spain (MCV); Instituto Valencia de Don Juan, Madrid, Spain (IVDJ-S) – was studied.

The chemical and morphological characterisation of the glazes was performed by Optical Microscopy (OM), Scanning Electron Microscopy with Energy Dispersive X-Ray Spectroscopy (SEM-EDS), μ -Raman Spectroscopy, and μ -Particle-Induced X-Ray Emission (μ -PIXE).

Two types of tin-opacified underglaze decoration were identified, allowing the distinction between Valencian and Sevillian-attributed tiles: *Type 1* is observed for flat Valencian tiles and characterised by small Co- or Mn-rich particles (< 15 μ m) scarcely distributed near the glaze-ceramic interface; *Type 2* was identified in *arista* and “low-*arista*” Sevillian-attributed tiles and is characterised by two distinct layers, where the lower one is composed of many inclusions related to the Co pigment, and the upper layer is more homogeneous and similar to the MCV glazes with its well-distributed tin oxide agglomerates. Further differences were identified in the chemical composition of the tin-glaze: *Type 1* glazes exhibit lower SnO₂ and higher K₂O contents than *Type 2* glazes, suggesting that different glaze recipes were used in the two

production centres. The chemical composition of the cobalt blue pigment fits within the expected Fe-Co-Ni-Cu association identified in Hispano-Moresque ceramics until the beginning of the 16th century. The morphology of the pigment particles exhibits a Fe-Co-Ni-rich nucleus with an outer layer rich in Si, Ca, Mg and Na, which may result from a prior mixture of the blue pigment with sand (as *zaffre*) or with clay.

The underglaze decoration technique using a tin-opacified glaze was widespread in the Valencian region and used sporadically in other ceramic centres, such as Seville. Considering that previously referenced literature on underglaze-decorated ceramics only mentions transparent glazes, this underglaze decoration using a tin-opacified white glaze represented a technological innovation.

Key-words: Cobalt, underglaze, tin glaze, ceramic tile, Hispano-Moresque.

BIBLIOGRAPHIC REFERENCES

- [1] Martínez Caviro, B. (1991) – Cerámica Hispanomusulmana andalusí y mudéjar, Madrid: Ediciones El Viso.
- [2] Coll Conesa, J. (2009b) – La Cerámica Valenciana: Apuntes para una síntesis. Asociación Valenciana de Cerámica. Valencia: Avec-Gremio/RM Ediciones.
- [3] Roldán, C., Coll, J., & Ferrero, J. (2006) – EDXRF analysis of blue pigments used in Valencian ceramics from the 14th century to modern times, *Journal of Cultural Heritage*, 7, p. 134-138.
- [4] Pérez-Arategui, J., Montull, B., Resano, M., & Ortega, J.M. (2009) – Materials and technological evolution of ancient cobalt-blue-decorated ceramics: Pigments and work patterns in tin-glazed objects from Aragon (Spain) from the 15th to the 18th century AD, *Journal of the European Ceramic Society*, 29 (12), p. 2499-2509.
- [5] Pleguezuelo, A. (2011) – Lozas y azulejos de Triana – Colección Carranza, Sevilla: Ayto.
- [6] Coentro, S. (2017) – An Iberian Heritage: Hispano-Moresque Architectural Tiles in Portuguese and Spanish Collections. PhD Thesis. Universidade Nova de Lisboa.

Portuguese Blue-on-Blue 16th-17th c. Pottery

I. Ferreira Machado¹, L.F. Vieira Ferreira² and T. M. Casimiro³

¹ *CQFM-Centro de Química-Física Molecular and IN-Institute for Nanosciences and Nanotechnologies and IBB-Institute for Bioengineering and Biosciences, Instituto Superior Técnico, Univ. de Lisboa, 1049-001 Lisboa, Polytechnic Institute of Portalegre, P-7300-110 Portalegre, Portugal. ilferreiramachado@tecnico.ulisboa.pt*

² *CQFM-Centro de Química-Física Molecular and IN-Institute for Nanosciences and Nanotechnologies and IBB-Institute for Bioengineering and Biosciences, Instituto Superior Técnico, Univ. de Lisboa, 1049-001 Lisboa, Portugal, luisfilipevf@tecnico.ulisboa.pt*

³ *Instituto de História Contemporânea e Instituto de Arqueologia e Paleociências da Universidade Nova de Lisboa. Departamento de História, Avenida de Berna 26-C, 1069-061 Lisboa, Portugal. tania.casimiro@tecnico.ulisboa.pt*

SUMMARY

Blue on blue (Berettino) sherds appeared in numerous production and consumption archaeological excavations in Lisbon and other archaeological sites in Portugal (mid 16th-beg 17th c.). The abundance of this interesting faience lead us to compare it with similar pottery from other well-known production centres in Italy, namely Liguria (Savona and Albisola), Spain (Triana kilns) and Low Countries.

Differences in the diffraction patterns of the sherds' pastes from the four countries were observed. In most samples cobalt blue silicate (cobalt olivine) was identified in the dark blue or light blue glazes by the use of micro-Raman spectroscopy and diffuse reflectance spectra.

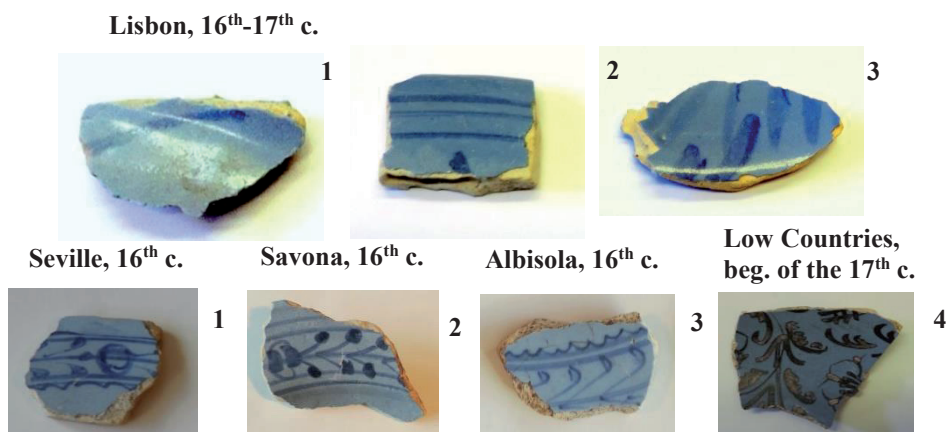


Figure 1 – Blue on Blue 16th-17th c. sherds

Taking into account the polymerization index (I_p), we determined $I_p = 0.8$ for the Lisbon blue on blue productions, and we estimated a 950°C kiln temperatures. The Spanish productions exhibit lower $I_p \sim 0.5$ to 0.7, pointing to kiln temperatures of about 850°C-900°C. Italian and the Low Countries productions also exhibit $I_p \sim 0.5$ - 0.7.

A remarkable difference in the calcite contents of the Lisbon and Seville pottery sherds was observed, in accordance with previous observations of high calcite contents of Seville ceramics. A comparison was also made for all blue on blue sherds studied here with many others 16th - 17th c. sherds from Lisbon using bivariate plots of K/Si vs. Ca/Si. Lisbon and Seville pottery

behave very differently, whereas Italian and Low Countries sherds occupy intermediate positions.

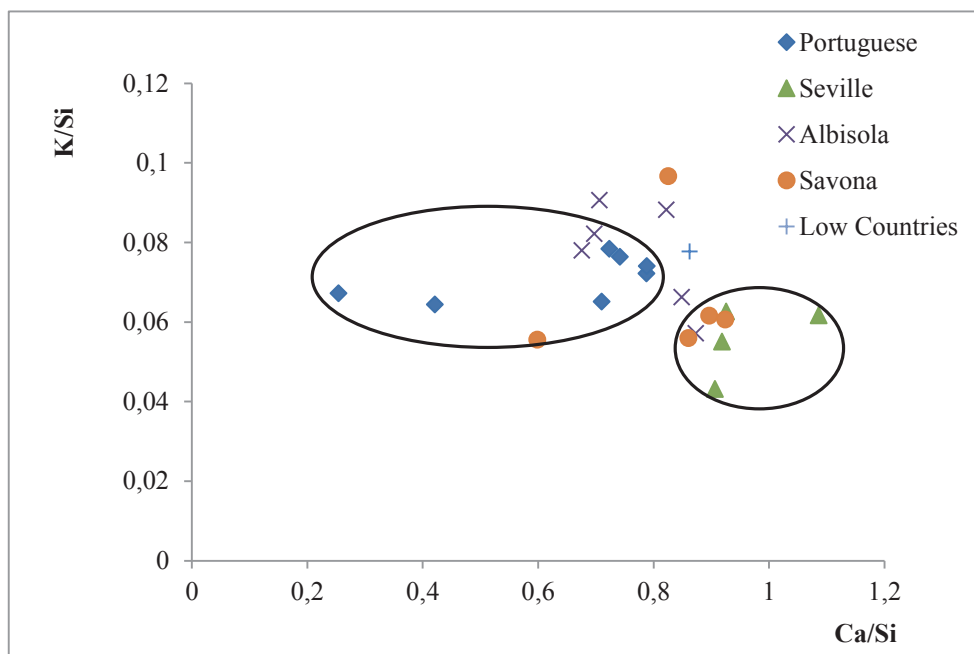


Figure 2 – Bivariate plot of K/Si vs. Ca/Si for blue on blue sherds from Lisbon, Seville, Savona, Albisola and Low Countries

This work demonstrates that Lisbon was not only producing a different type of pottery but supplying the internal market and possibly sending large amounts of this ware to Portuguese overseas colonies and even to North European countries and their colonies.

Key-words: Portuguese ancient ceramics, Lisbon blue on blue pottery, XRD, XRF, μ -Raman.

BIBLIOGRAPHIC REFERENCE

L.F. Vieira Ferreira, I. Ferreira Machado, T.M. Casimiro, M.F.C. Pereira, L.F. Santos, *Archaeometry*, 60, 4 (2018) 695–712. <http://dx.doi.org/10.1111/arcm.12336>.

The tile work of Jorge Colaço in workshop. From the order to the final artwork. The case study of S. Bento's railway station in Porto- Portugal

Cláudia Emanuel¹, Eduarda Vieira¹, Lurdes Esteves²

¹ *Escola das Artes, Centro de Investigação em Ciência e Tecnologia das Artes- CITAR, Universidade Católica Portuguesa, Porto, Portugal, claudia.emanuel@gmail.com*

² *Museu Nacional do Azulejo- Direção Geral de Património, Lisboa, Portugal*

SUMMARY

Jorge Colaço (1868-1942) was undoubtedly the greatest tile painter of the 20th century in Portugal.

Colaço began his artistic career as a tile painter in 1904. In the same year the first great order arose, the panel tiles for the Lisbon Medical School, made by the Count Paçô-Vieira. The second one was made by Emídio Navarro for decorating the Bussaco Palace. The third order occurred in 1905, after Fernando de Sousa, a member of the State Railways Administration, having knowledge of the previous tile panels produced by the artist. The quality of his drawings and painting was crucial for Fernando de Sousa ordering him the production of the lobby panels of the S. Bento Railway Station, in Porto.

After these orders Colaço's tile artwork became fashion and those who moved through artistic and literary circles, became his clients.

Usually clients most often defined what they wanted, or alternatively they gave the master the option of a final decision. Generally, both by the artist will or by the client choice, every order was preceded by previous studies. Colaço elaborated these studies following his imagination or the clients requests on watercolor or common paper. Alternatively, he transferred to the panels, images copied from photographs, postcards, prints, books or periodicals.

Soon after the production of the first panels, Jorge Colaço began experimenting new painting techniques, or adapting the existing ones. But he became well-known mainly by his painting technique on glaze already cooked. This technique allowed him to remake or change the drawings before the tiles were last baked. The analysis made to the Colaço's photographic collection belonging to the National Tile Museum, in Lisbon and to photographs published by coeval periodicals, allowed us to confirm subsequent modifications made by the artist in his panels. The S. Bento Railway station is the most paradigmatic one.

It is known that the panels were ready to be applied in 1906, but they were only placed in the lobby in 1915, one year before its inauguration. The final version of these panels show differences in some figures positions and architectonic elements when compared with the original draws. Where these changes made by Colaço's choice or where they imposed by aesthetics or historic reasons?

Despite the S. Bento railway station is not a single case study of this kind of practice within Colaço's artwork in this communication we will highlight these issues in the framework of their inherent tangible and intangible values.

Key-words: Colaço, Cliente, S. Bento Railway station, National Tile Museum, Photographic Sources

Apeiron – ἄπειρον – and Havoc: Beauty in Aalto's tiles

Joaquim Marcelino Santos^{1,2}

¹ Architect, PhD, Tampere University of Technology, Tampere, Finland

² Professor at the Lusíada University, Lisbon, Faculty of Architecture and Arts (UL); CITAD, Research Center for Territory, Architecture and Design (UL); marcelino.c.santos@gmail.com

SUMMARY

Classicism and medievalism come together in Modern Architecture as a symbol of the ancestry of man and of western civilization. Yet, such cross roads were also explored by architects to comprehensively develop their own styles. In addition, the overwhelming sense of an «international revolution» in architecture and civilization will produce a manifestation of regional cultures. In this context, the glazed tiles in Aalto's oeuvre seem interesting to explore because they symbolise the erudition of classicism, the importance of craftsmanship and also, the importance of industry under the full control of human will.

INTRODUCTION

Had not Xenophanes created the *apeiron*, Aalto's tiles would never have been created!

The symbolic representation of the apeiron in the Doric, Ionic and Corinthian is certainly a *motif* that links them and its metamorphosis into a coloured tile that has acquired special significance in Aalto's oeuvre. Yet, in Aalto the outer circle of the *anathyrōsis* has acquired some life of its own. Perhaps as a consequence of an intricate multiple reference in which post-Enlightenment analytical construction regarding pillars, floor slabs and walls combines with cubist ideals. Namely, work on the essence of the object in space-time and the expressionist unity between an inner and outer world of mind are to be expressed par excellence through the object.

The presence of the tile expresses and combines different arguments where the classical tradition, the vernacular tradition and craftsmanship coincide. Herman Gesellius, Armas Lindgren and Eliel Saarinen had already given a high erudite and mature interpretation of the tiles at the Helsinki Central Railways Station and established some equivalence in relation to materiality and aesthetic expression from tile to plaster and to stone.

Aalto's famous curved tile presents breadth that is permeable to work in a sense of scale that combines the Classical and the Functionalist. A sense of architectural promenade that may suggest a *quantum continuum*, and that is a multidimensional infusion of the individual into space. This is due to several strategies and includes the distribution of tile within space. Thereby, emerges the sense of tile as a structural surface that disputes its rule with both finished and coated layers with main structural parts of the building. All of which can be regarded as a critical constructivist reading, and as ornament.

THE ROLE OF THE ORDER: PROPORTION AND ORNAMENT

Aalto's glazed tiles present a comprehensive criticism of the column in which it becomes a *spatio-temporal* element that organises the architectural discourse and our presence in it. And Aalto used a few colours, too. The distance from the floor to the line where tiles start is always different from the distance where they end to the ceiling. There is a clear discourse that is also tectonic by identifying the different parts of the architectural composition of space. Yet, Aalto's curved glazed tiles display a certain depth. They are actual three-dimensional elements. So, on a similar way to Eliel Saarinen's green glazed tiles in the Helsinki Railway station, Aalto's tiles construct a three-dimensional surface of solids and voids whose vertical expression owes much to the apeiron of the Greek columns.

Aalto's attitude also means that he reversed the classical order extensively because the base and the top appear free of any ornament and the later has been moved to the body of the column. This means that Aalto actually had a deep knowledge of classicism and the simplification of volumes provided by the Architects of the Revolution was short to answer the problems of the Functionalism.

GLASS STORIES: ART AND NATURE

Aalto's glazed tiles wouldn't have been possible without the emergence of the new Finnish artistic glass that comprises a whole approach to glass materiality and colour from craftsmanship, to design, to sculpture. This is a tradition that was renovated along with the development of Modern Architecture and deserves attention. This is an artistic environment where artist met, architects, designers and sculptors certainly worked on ideas of glass and ceramics expression that mingled intricately.

Culturally, to the Finns, all development from the craftsmanship to the industrial through the aesthetic was synonymous with Finnish *sisu* that can be translated as perseverance, but *never-ending-perseverance* could be a better translation. If one aims at a complete and comprehensive story that may bring craftsmanship to state-of-the-art technology, glazed tiles are certainly at the core of such story and Aino-Marsio and Alvar Aalto are certainly privileged actors. Aalto's oeuvre also takes us to the debate of the role of classicism in Modern Architecture. The representation of the apeiron – ἄπειρον – in Aalto's columns synthesize an ancient *tempo* former to the classical where the intellectual work and craftsmanship were not two distinct ideas. Perhaps, there were many ways of inquiring into history, but the heuristic exploration of bricks and glazed tiles held by Aino-Marsio and Alvar Aalto was certainly remarkable and needs further exploration.

Key-words: Aalto, Saarinen, tiles, Finnish, Functionalism

Chemical characterization of the glassy phase of glazes from 17th century *majolica azulejos*

Augusta Lima¹ and Carlo Pantano²

¹ Department of Conservation and Restoration and Research Unit VICARTE – Glass and Ceramics for the Arts, Faculdade de Ciências e Tecnologia, Universidade NOVA de Lisboa, Caparica, Portugal, arl@fct.unl.pt

² Department of Materials Science and Engineering, Materials Research Institute, The Pennsylvania State University, University Park, PA, USA, cgp1@psu.edu

SUMMARY

Portuguese 17th century *majolica* tiles, or *azulejos*, are coated with a white opaque lead-tin glaze typically decorated with in-glaze polychrome patterns. These tin-opacified glazes exhibit a heterogeneous microstructure due to the presence of the opacifying crystals of cassiterite (SnO₂), gas bubbles and a variable amount of crystalline particles dispersed on the glassy phase. In archaeometric studies of glazed ceramics, the chemical characterization of the glassy phase in glazes provides information about the base composition of the glaze, thereby contributing to the distinction of production centers and periods.

In the present study, the chemical composition of the glassy phase of glazes from *azulejos* dating from the late 16th to the early 18th centuries is presented. The glaze samples were collected from a set of twelve *azulejos* from the National Tile Museum (*Museu Nacional do Azulejo*), of which ten are attributed to Portuguese production and two have an uncertain provenance, one is seemingly from Portugal or Spain and the other from Flanders or Spain. The analysis was performed by X-ray electron probe microanalysis (EPMA) on polished cross-section samples, in regions free of particles and without painting, to avoid contamination by colorants. Results revealed that the glassy phases are lead-alkali silicate glasses with contents of SiO₂ in the range 55-61 wt%, PbO between 20-28 wt% and total alkali (Na₂O + K₂O) contents in the range 7.1-9.2 wt%. The contents of CaO are very low, usually not exceeding 1.5 wt%, whereas the contents of Al₂O₃ are relatively high, in the range 4.4-6.5 wt%. The glassy phase of the *azulejo* presumably from Flanders or Spain contains a much lower content of Al₂O₃ (ca. 2.5 wt%) and the highest content of CaO (ca. 2.5 wt%) than those of Portuguese *azulejos*, which indeed point to a non-Portuguese origin. The glassy phase of the *azulejo* from Spain or Portugal is comparable to those of Portuguese production. In a general way, the compositions obtained for the glassy phases of Portuguese *azulejos* show higher contents of SiO₂ and Al₂O₃ and lower contents of CaO than the compositions reported for glazes of Renaissance Italian *majolica* from Urbino and Pesaro.

Key-words: Azulejos, majolica, glazes, glassy phase, EPMA.

On the use of glaze and ceramic body analytical spectra in heritage azulejos as beacons of provenance

João Manuel Mimoso¹, Maria Augusta Antunes¹, Sílvia Pereira¹, António Candeias² and Alexandre Pais³

¹ *Laboratório Nacional de Engenharia Civil, jmmimoso@lnec.pt*

² *Laboratório HERCULES- Universidade de Évora*

³ *Museu Nacional do Azulejo*

SUMMARY

Studies of provenance of ceramic items or most other heritage specimens usually rely on analytical quantification followed by some form of “objective” decision-making to aggregate clusters of (hopefully) objects with the same provenance. Such studies often produce an impressive array of instrumental results, out of which it is increasingly difficult to make sense, even when the researcher is personally certain that there must be some way to extract a measure of reasonably trustworthy conclusions from the data. Looking for objectivity to base the conclusions the researcher will apply a number of numerical methods some of which stemming from the statistical treatment of the data. However, there is a catch in all those methods and it is the same in all statistical decision-making: at some point the researcher is always called to make a subjective decision. Why exclude from a cluster another result very near its limits in the graphical representation? How to know whether a point included in a boundary is not actually an outlier from some other different cluster? Or, in general, what are the critical values of the test statistic that separate the rejection from the non-rejection region?

We are not going to propose a solution ruling away all subjectivity. On the contrary, we shall discuss another subjective approach to help cluster glazed ceramic specimens based solely on spectroscopic spectra but applicable to other analytically complex objects. A compelling feature is that it does not require quantification, resorting directly to the graphical spectra themselves and the subjectivity derives from the need to verify whether the closeness between spectral results is sufficient to grant tentative clustering. In this method special attention should be placed on using the same analytical equipment and the same conditions (e.g. the same acquisition time) to acquire the spectra and used under the same conditions. If conditions differ, they may affect the relative size of peaks and the evenness of the baselines making comparability more difficult.

Glazed ceramics offer at least two different spectra for comparison, those acquired from the glaze and those acquired from the ceramic body. Information from both can be useful to attribute the items their provenance. A similarity of ceramic bodies might suggest a same geographical origin and a similarity of glazes might point to the use of a same formulation or workshop.

But spectra are not just graphs in an x-y coordinate system - peaks have a chemical meaning and can be translated into elemental contents if one knows the material and has the means for that second step. In all cases they offer a wealth of information but it is necessary to know how to interpret them and for that is necessary knowledge about the materials, the analytical techniques used, and the counterparts of the analytical results.

In this paper, we discuss the elemental nature of glazes and ceramic bodies and explain their consequences on the approach proposed. Although we have also successfully used this approach with spectra obtained on sites with an energy-dispersive X-ray fluorescence (ED-XRF) portable analyser, we shall exemplify it solely with spectra acquired by scanning-electron microscopy coupled with energy-dispersive spectroscopy (SEM-EDS). The examples pertain to our on-going research with faience azulejos.

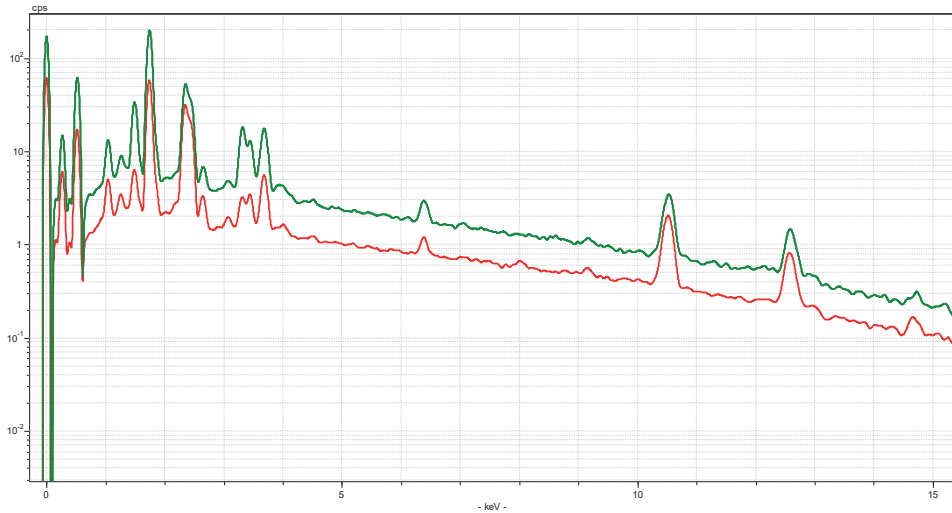


Figure 1 – EDS spectra of azulejo samples (red) and (green) of different provenance- the peaks of Si have been equalized and, as can be seen, the peaks of Al, Pb and K differ substantially.

This is not a solve-all method but rather one that has borne fruit for an initial screening and the formulation of arguable hypotheses as to the possible clusters. The full method proceeds with a study of the morphology of the glazes, their composition as pertains the Si/Pb ratio, the ceramic bodies again based on the simple but highly significant ratio Ca/Si and the mineral inclusions found in them. But that is a subject needing a few more papers to develop...

Key-words: Provenance studies; majolica; archaeometry; tiles, XRF, SEM-EDS.

ACKNOWLEDGEMENTS

Communication produced as an outcome of Project FCT-AzuRe - Estudos no Azulejo Português para Candidatura a Património da Humanidade (PTDC/EPH-PAT/5096/2014) funded by FCT, the Portuguese Foundation for Science and Technology.

LNEC Research Project 0202/111/19747.

Silvia Pereira acknowledges FCT for her Post-Doc grant SFRH/BPD/116807/2016.

Unknown Porto - the use of azulejos in the modern architecture of the northern Portuguese town

Catarina F. M. Gerales¹, João Manuel Mimoso² and Alexandre Pais³

¹ *Departamento de Conservação e Restauo, Faculdade de Ciências e Tecnologia, Universidade NOVA de Lisboa, Caparica, Portugal; Laboratório Nacional de Engenharia Civil (LNEC), Lisboa, Portugal; cgeraldes@lnec.pt*

² *Laboratório Nacional de Engenharia Civil (LNEC), Lisboa, Portugal*

³ *Museu Nacional do Azulejo, Lisboa, Portugal*

SUMMARY

During the 19th century, tiles (azulejos) started to be used mostly in urban façades, a novel application that opened the way for the “faience towns”. However, by the late 1930s, azulejos were considered something outdated, unworthy of integration in the modern architecture [1]. As earlier discussed by the authors [2] with the reintroduction of the azulejo in Brazilian modern architecture during the 1940s, its role as a regional marker rooted in a prestigious history was recognized by young Portuguese architects who started integrating them in modern constructions in the first half of the 1950s.

During the first years of the 20th century, the progress of Porto was marked by a significant urban expansion to the outlying areas with a progressive incorporation of the rural zones [3] and stands as a Portuguese town where modern azulejos were used not only in a striking number of works, but also with great creativity.

Some studies have been undertaken, specifically in the field of art history of the modern movement in Portugal, with the identification of modern azulejos in public spaces in the main Portuguese towns [4-7]. information relating to integrated modern azulejos in Porto city is scant. The authors believe that these cases are worth paying attention to, not only because they mark an architectonic period in the city, but also because of their originality at the European level. The discussion considers all use of glazed ceramics with decorative content. Table 1 shows the cases found in Porto and Vila Nova de Gaia in a first review (48 and 3 respectively).

Table 1 – Number of azulejos found in Porto and Vila Nova de Gaia

Cities	Number of cases
Porto	48
Vila Nova de Gaia	3

All cases are considered from the point of view of a street walker and sometimes a pattern can be found in several different buildings with different possibilities of position, creating new and totally different compositions (Figure 1). Occasionally the glass mosaics *Evinel* or even *marmorite* were used in harmony with azulejos which were options that often complemented or replace azulejos as linings of the modern buildings.

One interesting aspect in Porto is the fact that several buildings have interesting azulejo integrations in streets of low-cost housing where a cheaper solution might be expected. Most cases depict a modern repetitive pattern, in general with a simple design, that may be locally produced and often found at street level or covering most of the façade. In most of the cases, such patterns are rarely seen in Lisbon and, as far as the authors know, they are not found in the literature.



Figure 1 – Three geometries of application with the same pattern. Left: *R. de Júlio Dinis N° 896*; centre: *Av. da Boa Vista N° 1624*; right: *Av. da República N° 1473 (Vila Nova de Gaia)*

It is important to note that aesthetic value is decreased or even lost when the decorative glazing has decayed, once the impression is affected by both the alteration of colours and design and, even by the loss of the azulejos themselves, modifying the entire composition. Therefore, conservation is essential to enable the recognition of modern azulejo linings as a heritage asset representing a unique movement in Europe.

Key-words: Azulejos, Porto, modern architecture, Portugal

ACKNOWLEDGMENTS

The authors acknowledge the Portuguese Science Foundation (FCT) for the funding of PhD grant PD/BD/114408/2016 (Catarina Geraledes) and Project FCT-AzuRe - Estudos no Azulejo Português para Candidatura a Património da Humanidade (PTDC/EPH-PAT/5096/2014) supporting this research.

BIBLIOGRAPHIC REFERENCES

- [1] SILVEIRA, Marciele - *O azulejo na modernidade Arquitêtonica (1930-1960)*. Master dissertation, São Paulo University. DOI: 10.11606/D.16.2008.tde-25032010-154757, 2008.
- [2] GERALDES, Catarina; PAIS, Alexandre; MIMOSO, João Manuel - *The Integration of Azulejos in the Modernist Architecture of Portugal as a unique case in Europe*, In: M. Menezes, D. R. Costa, J. D. Rodrigues (eds.) Congress Book Proceedings for the IPERION CH international conference - Intangibility Matters, Lisbon, 29-30 May 2017, pp 139-147.
- [3] FERREIRA, Nuno - *A arquitetura rural na cidade do Porto na primeira metade do século XX: Construção de quintas em contexto de expansão urbana* [Online] http://www.citcem.org/3encontro/docs/pdf/part_011/Nuno%20Ferreira.pdf [Accessed 25 June 2018].
- [4] HENRIQUES, Paulo et al. - *O Azulejo em Portugal no século XX*. No. of edition ISBN 972.787.009.0, Editor Inapa, Lisboa, 2000
- [5] AMORIM, Sandra - *Azulejaria de Fachada na Póvoa de Varzim (1850-1950)*. No. of edition ISBN 972-97058-0-1, Editor Póvoa de Varzim, 1996, 2001.
- [6] NERY, Eduardo - *Apreciação Estética do Azulejo*. No. of edition ISBN 978-972-797-150-3, Editor Inapa, Lisboa, 2007.
- [7] AMARAL, Ricardo - *Arquitetura & Cerâmica: o espaço da tradição mural na contemporaneidade*. Master dissertation. Porto University, ID: 2015.

Biodeterioration of glazed tiles by lichens

Mathilda L. Coutinho¹, Ana Teresa Caldeira², Ana Z. Miller³, Cesareo Saiz-Jimenez⁴, Antonio Gómez-Bolea⁵, Maria Filomena Macedo⁶, João Pedro Veiga⁷ and Augusta Lima¹

¹ *Research Unit VICARTE – Glass and Ceramics for the Arts, Faculdade de Ciências e Tecnologia, Universidade NOVA de Lisboa, Caparica, Portugal, mathildal@gmail.com*

² *Laboratório Hercules (Universidade de Évora), Évora, Portugal, atc@uevora.pt*

³ *Instituto de Recursos Naturales y Agrobiología de Sevilla (IRNAS-CSIC), Seville, Spain, anamiller@irnas.csic.es*

⁴ *Instituto de Recursos Naturales y Agrobiología de Sevilla (IRNAS-CSIC), Seville, Spain, saiz@irnase.csic.es*

⁵ *Department of Evolutionary Biology, Ecology and Environmental Sciences (University of Barcelona), Barcelona, Spain, agomez@ub.edu*

⁶ *Department of Conservation and Restoration and Research Unit VICARTE – Glass and Ceramics for the Arts, Faculdade de Ciências e Tecnologia, Universidade NOVA de Lisboa, Caparica, Portugal mfmd@fct.unl.pt*

⁷ *CENIMAT/13N (Faculdade de Ciências e Tecnologia da Universidade NOVA de Lisboa), Caparica, Portugal, jpv@fct.unl.pt*

SUMMARY

The repercussions of lichen colonization on glazed tiles have not been studied, leaving institutions that detain glazed tiles with the difficult decision of whether to remove the lichens or not. Glazed tiles are part of the cultural identity of countries worldwide where they have been traditionally applied and are therefore part of the Portuguese cultural heritage [1]. Glazed tiles are often located outdoors which causes them to be frequently colonized by lichens, which in turn interferes with the readability of tile claddings and can cause irreversible physical decay (Fig. 1). Given the high importance of glazed tiles, their preservation is an urgent need, since lichens can cause irreversible losses on inorganic substrata. Lichens can be damaging on stone and ceramic roofing tiles, causing physical and chemical decay of the substratum due to the penetration of structures and acid excretion [2–4]. Although ceramics are resistant materials, outdoors they become exposed to diverse threats, including biodeterioration which can cause severe damages. Little is known about the biodeterioration of glazed tiles, compared to that of other inorganic materials [5]. However, the studies regarding glazed tiles have focused on the identification of bacteria, cyanobacteria, algae and fungi, excluding lichens which are also tile colonizers. Lichens can grow on various substrata, as a symbiosis of phototrophic microorganisms and a fungal partner, allows them to be highly adapted to extreme environments [1]. Typically the fungus is responsible for most of the organism's structure providing shelter for the exchange of carbohydrate produced by the photosynthetic partner. Lichens can therefore inhabit a much wider variety of habitats and conditions.

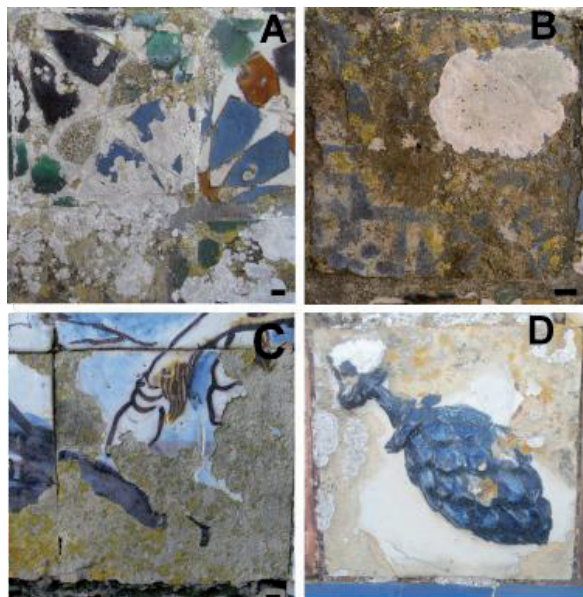


Figure 1 – Tiles colonized by lichens. Hispano-mouresque tiles from Sintra National Palace (Sintra) with little epilithic lichen thalli, some of them coalescent (A), majolica tile from Sintra National Palace (Sintra) with big white epilithic lichen thalli and yellow-orange thalli of another species (B), majolica tile from Fronteira Palace (Lisbon) with yellow-orange lichen thalli, only on the surfaces without glaze (C) and high relief majolica tile from Fronteira Palace (Lisbon) with white and yellow-orange lichen thalli, only on the surfaces without glaze (D).

The main goals of this project will be to elaborate an inventory of the type of colonizer, identify which organisms or organism assemblages contribute in a major way to biodeterioration and to establish the climatic factors related to the colonizers occurrence. In the present work a preliminary list of tiles claddings colonized by lichens is presented.

Key-words: Glazed tiles, ceramic, lichens, biodeterioration

ACKNOWLEDGEMENTS

This study was supported by *Fundação para a Ciência e a Tecnologia* (FCT) under the Post doc grant in Vicarte - UID/EAT/00729/2013.

BIBLIOGRAPHIC REFERENCES

- [1] VAN LEMMEN, H - *Tiles 1,000 Years of Architectural Decoration*, Harry N. Abrams, New York, 1993.
- [2] CHEN, J. BLUME, H.P., BEYER L. - *Weathering of rocks induced by lichen colonization — a review* *Catena* 39, 2000, 121.
- [3] MARQUES, J., HESPANHOL, H., PAZ-BERMÚDEZ, G., ALMEIDA, R., *Choosing between sides in the battle for pioneer colonization of schist in the Côa Valley Archaeological Park: a community ecology perspective*, *Journal of Archaeological Science*, 45, 2014196.
- [4] RANOGAJEC, J.G., KIURSKI, J.S., UJHELJI, A.L., RADEKA, M.M., BOKOROV, M.T., BALINT, J., BORBELJ-MESAROS, A. - *Biochemical corrosion of ceramic roofing tiles by lichen actions*. *Inter Ceram*, 54, 2005, 340.
- [5] COUTINHO, M. L., MILLER, A. Z., MACEDO, M. F. - *Biological colonization and biodeterioration of architectural ceramic materials: An overview* *Journal of Cultural Heritage*, 16, 2015. 759-777



GlazeArt2018

International Conference
Glazed Ceramics in Cultural Heritage

Full Articles

Signatures and authorship marks on Portuguese *azulejos* (16th-18th centuries)

Rosário Salema de Carvalho

Az – Rede de Investigação em Azulejo, ARTIS – Instituto de História da Arte, Faculdade de Letras da Universidade de Lisboa, Lisbon, Portugal, rscarvalho@letras.ulisboa.pt

Francisco Queiroz

Az – Rede de Investigação em Azulejo, ARTIS – Instituto de História da Arte, Faculdade de Letras, Universidade de Lisboa, Lisboa, Portugal, correio@franciscoqueiroz.com

*SUMMARY: Intending to analyse the signatures found on Portuguese *azulejos* since the beginning of the 16th century until the middle of the 18th century, this article is part of a wider study which aims to compare the common practices of Modern Age artists' workshops, in terms of authorship, with those of the second half of the 19th century (and beginning of the 20th century), following a new paradigm, rooted in the establishment of Fine Arts academic teaching in Portugal. Conscious that studies on Portuguese *azulejos* rarely explore all the information about signatures and authorial marks, systematization of signatures as proposed here paves the way to the emergence of specific questions, such as: What could make a tile painter not sign his work?; How can we explain the larger number of signed tiles in specific periods?; What was the real meaning of complementing the signatures with expressions like "f.", "fecit", "fez" (did), "pintou" (painted), "inventou" (invented), "copiou" (copied), "restaurou" (restored), and others, particularly if we consider the fact that painters usually had apprentices and collaborators?; Can we really think about a conscious creative individuality behind these signatures?; What kind of resources and strategies have tile painters used to embellish, highlight or even dissimulate their authorship marks?*

*KEY-WORDS: *azulejos* (tiles), painters, signatures, Portugal*

INTRODUCTION

In the early 20th century, the authorship of the Portuguese *azulejo* (glazed tile) was widely discussed by Art History. Liberato Telles¹, José Queirós² and Vergílio Correia³ were some of the authors who, at an early stage of the tile studies, were more concerned with collecting lists of signed and dated *azulejos*. The compilation of signatures and related records allowed for the creation of artistic *corpora* that still help researchers in what concerns attributions, thus progressively increasing the number of works associated to each painter. Nevertheless, the studies on Portuguese *azulejos* rarely explore all the information about signatures and authorship marks, in order to overcome the mere identification of the author and the year.

Indeed, even at an international level, many authors argue that the issue of signatures has never been properly explored by Art History⁴. However, this does not fully correspond to reality, as there are several reference articles on this subject discussing this particularly rich and complex phenomenon, which is that of signatures in painting. Issue 26 of the *Revue de l'Art* (1974) is precisely dedicated to "*L'art de la signature*", with ten articles on this theme. The one by Jean-Claude Lebensztejn⁵ stands out for the typology enunciated, later used by many of the

researchers who address artists' authorial marks. Other important essays were written by Omar Calabrese and Betty Giant⁶ from a semiotic perspective, or by Patricia Rubin⁷, in which she analyses a series of cases of Renaissance art, in an approach that goes far beyond the identification of signatures, putting them into context and giving them other meanings. Interesting to us is the evolution she traces on signatures as documents⁸.

Returning to the *azulejo*, the present paper is part of a much wider approach aiming to reverse this situation by encompassing a deeper analysis on signatures in Portuguese *azulejos* within a time period running from the beginning of the 16th century to the first decades of the 20th century⁹. The choice of such a wide time-span will allow us to compare the common practice of the artists' workshops of the Modern Age, in terms of authorship, granting us the opportunity to clearly identify periods with a larger number of signed tileworks, in contrast to others for which almost no authorial marks are known. Moreover, this long period of time allows us to propose a correlation between the greater or lesser presence of signed tileworks with the typologies of *azulejo* coverings that were predominant in each epoch and the inherent production practices. Also, it leads to issues of painters' social status as well as of the artistic and cultural context. However, due to the constraints of an article, we will move only one step forward by systematizing the identification of variations, abbreviations, numbers, Latinizations, ornaments or complementary expressions from the beginning of the 16th century to the middle of the 18th century. All the information used is available online, organized in photographic albums and in a timeline, thus contributing to different and new data visualisations¹⁰.

THE FIRST "SIGNATURES"

Concerning the long history of Portuguese *azulejos*, and with the exception of drawings made by artists, architects or designers from the middle of the 20th century, pattern tiles are usually anonymous, either as regards the design of the compositions¹¹ and the painting, executed serially and without a sense of individuality. In any case, in the 19th and 20th centuries many factories became "authors", identifying on the backside (*tardoz*) the place of production. However, there are different options: while the signatures of painters are included in the space of representation, these of the factories are usually separated from the images¹² and are commonly more mechanical marks (made with a mould) than true signatures. In fact, they are often intrinsic to the object itself and are hidden from the observer, albeit in a more or less visible way: either before its application – in the case of tile, which is a mobile art that only makes sense integrated into the architecture – or in the case of a removal.

Thus, and in an extended perspective that considers as signatures all the declarations of authorship, even though they may not have been made by the authors themselves¹³ the oldest authorial mark known in Portugal is of Niculoso Francisco Pisano¹⁴ (mid-15th century-<1529). Although the provenance of the *Visitation* panel (c. 1504), now in the Rijksmuseum (BK-NM-11727) remains unknown, it belonged to D. Fernando II's collection. As can be seen on other panels painted by him, Niculoso wrote his name on a phylactery – *NICVLOSO ITALIANO / ME FECIT* – out of the representation space.

In Portugal, the first signature remaining in situ, despite of not being in its original space, is of Antwerpian origin. We refer to the monogram "F IAB" and the date "1558" present in an *azulejo* of the covering that tells the story of Tobias, originally applied in the Paço Ducal of Vila Viçosa (two panels are now integrated in the collection of the National *Azulejo* Museum)¹⁵. Considered as the first majolica decoration applied in our country, this covering was associated by Santos Simões to the Antwerp production and, in particular, to the *Den Salm* workshop, in a perspective followed by other researchers¹⁶. However, despite the identification of a similar monogram in the Antwerpian production, the meaning of the initials "F IAB" remains unclear. Santos Simões interpreted it as *Fecit Joanes A Bogaerts*, thus associating these *azulejos* to one

of the painters named Bogaerts (father and son) active in Antwerp in this period¹⁷. On the other hand, Claire Dumortier identifies Jan Bogaerts at the *Maeght van Gent* pottery, and argues that only the Den Salm pottery would be able to produce tiles of this technical quality, approaching them to others associated with the same provenance¹⁸. At the time of this commission – 1558 – that pottery was directed by Franchois Frans, who married the widow of Guido Andries. For this reason, Dumortier chooses to attribute the tiles of Vila Viçosa to this pottery under the command of Frans, but without recognizing the monogram, which she claims to belong to a painter as yet unidentified¹⁹.

The issue of monograms related to Northern European ceramic production is very relevant in this context, because another codified name was found in the *azulejos* covering a space right at the entrance of the sacristy of the Convent of Graça, in Lisbon, with representations of Mannerist motifs²⁰. The comparison between tile painting and archival documentation allows researchers to identify this "symbol" of HG and the number 4+ (and the associated name) as the signature of João de Góis (act 1553-c.1590). Of Flemish origin and established in Portugal, this "*oleiro de azulejo e malega*" (potter of tile and *malega*)²¹ worked with his brother, the painter Filipe de Góis. In this case, it should be highlighted that the signature on the tiles is not that of the painter, but that of the potter, at a time when the importance of pottery as a space of technological innovation (at the level of glazes and ceramics paints), assumes a greater relevance if compared with the "status" of the painter²². On the other hand, and observing the existing studies²³, the signatures with monograms are inscribed in the tradition of Nordic painting and engraving, and also of the ceramic production itself, which is of particular relevance in what concerns the introduction of majolica in Portugal.

The next known signature is from Francisco de Matos, who in 1584 signed the covering of the Chapel of São Roque, located in the homonym church in Lisbon – "*FR CO DE MATOS 1584*". Associated by other researchers to the same Matos family is the fragment with the letters *TOS* existing in Quinta da Bacalhôa, Azeitão²⁴.

Thus, between 1558 and 1584, there was an unfolding of the signatures in Portuguese *azulejos*, which became immediately readable, leaving "unforeseen" places or forms²⁵, which would easily go unnoticed, into spaces where they are immediately visible and comprehensible, as happens in the Church of São Roque (see table 1).

Painter	Place	Date	Signature
Niculoso Francisco	<i>Visitation</i> , Rijksmuseum (BK-NM-11727) [from D. Fernando II collection]	1504	<i>NICVLOSO ITALIANO / ME FECIT</i>
Not identified	Vila Viçosa, Paço Ducal	1558	<i>F IAB 1558</i>
João de Góis (potter)	Lisboa, Church of the former Convent of Graça, space before the sacristy		<i>4+ / J(...) HG de g(...)</i>
Francisco de Matos	Lisboa, Church of São Roque, Chapel of São Roque	1584	<i>FR CO DE MATOS 1584</i>
Not identified	Azeitão, Quinta da Bacalhôa		<i>(...)TOS</i>

Table 1: 16th century signatures

THE IMPORTANCE OF SIGNATURES IN THE BAROQUE PERIOD

Even though some researchers who most valued signatures affirm that "from now on, tilers and potters have begun to date and to sign their works (...)"²⁶, we would have to wait until the last decades of the 17th century to find new signatures in tile painting, again, many of foreign origin.

This change coincides with a significant modification in the tilework itself. From the second half of the 16th century until the beginning of the 17th century, a number of coverings of Dutch origin were applied in Portugal signed by the painters Jan van Oort (1645-1699) and Willem van der Kloet (1666-1747) (see table 2). At the same time, national production slowly abandons the polychrome patterned *azulejos* that had marked the previous decades and figurative coverings executed, like the Dutch, in blue over white, began to emerge. This opened the important narrative cycle marked by the full coverage of spaces or by the articulation between *azulejos* and other artistic forms, such as gilded woodwork and oil and ceiling paintings, which would characterize the Baroque period, highlighting it as one of the most relevant in the history of Portuguese *azulejos*.

Painter	Place	Date	Signature
Jan van Oort	Lisboa, Convent of Cardaes, Church	<1687 [?]	<i>J : Van : Oort / A : Amst : fecit :</i>
Willem van der Kloet	Lisboa, former Palace Galvão Mexia, Chapel	1707	<i>Willem / van der Kloet fec.</i>
	Sítio da Nazaré, Sanctuary of Nossa Senhora da Nazaré	1708- 1709	<i>W. V D, Kloet f</i>

Table 2: 17th and 18th century foreign signatures

Jan van Oort and Willem Van der Kloet signed their works in visible places, indicating the name (complete or abbreviated), associating the expression *fecit* or just its abbreviation – *fec.* or *f.* – and, in the case of the first, the abbreviation of Amsterdam, a situation that will only be repeated later with Teotónio dos Santos (1688-?) and the tiler Bartolomeu Antunes (1668-1753). In the context of Van der Kloet’s works, it is interesting to note that the tiles applied in Portugal are signed.

As regards Portuguese *azulejo* painters, it is important to analyse their signatures according to various criteria – textual content and placement. Let us begin by making a summary of the well-known painters and their signed works, all of them figurative (see tables 3, 4, 5 and 6):

- **Gabriel del Barco** (1648-?), was a Spanish painter who established himself in Portugal from 1669 onwards, signed sixteen works (it is known from documentation that he painted another one, now lost), from the north of the country to the Alentejo, in a chronological period between 1689 and 1700 (fig. 1);



Fig. 1: Gabriel del Barco, Arraiolos, Church of the former Convent of Lóios

- **Garcia Ramires**, about which nothing is known other than an *azulejo* signed and dated 1691, related to an eventual commission of tiles for the former Francesinhas Convent (Lisbon), from which came the tile that is now in the National *Azulejo* Museum;
- **Raimundo do Couto** (act. 1684 - m. 1711), who, like Gabriel del Barco, was also a ceiling painter, signed a single work possibly dated from the first decade of the 18th century;
- **António Pereira** (associated by some researchers with the easel painter António Pereira Ravasco²⁷) signed three *azulejos* coverings, one in Portugal and two in Brazil;



Fig. 2: António de Oliveira Bernardes, Évora, Church of Nossa Senhora da Cabeça

Fig. 3: Master P.M.P., Barcelos, Church of Terço, main chapel

Fig. 4: Policarpo de Oliveira Bernardes, Viana do Castelo, Church of Misericórdia (photo by Santa Casa da Misericórdia de Viana do Castelo)

- **António de Oliveira Bernardes** (1668-1732), who owned the most important painting workshop in Lisbon in the first quarter of the 18th century, even for its multidisciplinary nature – his workshop produced tiles, canvas and mural paintings –, signed at least eight coverings (fig. 2);
- **Policarpo de Oliveira Bernardes** (1695-1778) continued his father's workshop in the area of *azulejos*, signing works since the 1720s, a total of eight known with signature (fig. 4);
- **Manuel dos Santos** signed three *azulejo* coverings;
- **Master P.M.P.** signed three *azulejo* coverings whose signatures still exist, although there are references to other works that have disappeared (fig. 3);
- **Teotónio dos Santos** (1688-?) signed two *azulejo* coverings;
- **Nicolau de Freitas** (1703-1765) signed three *azulejo* coverings;
- **Bartolomeu Antunes** (1668-1753), who was not a painter but a tiler, signed five *azulejo* coverings, two of which were complemented by the signature of the painter, his son-in-law Nicolau de Freitas.

Painter	Place	Date	Signature
Gabriel del Barco	Évora, Convent of Espinheiro, main chapel	1689	<i>B.^{co} 1689</i>
	Barcarena, Estate of Nossa Senhora da Conceição, Chapel of São João Baptista	1691	<i>D. Gabriel del / Barco F. 1691</i>
	Braga, Church of São Victor	1691 [?]	<i>G. B</i>
	Ílhavo, Church of Penha de França	1694	<i>G.I B.^{co} 1694</i>
	<i>Azulejo</i> [MNAz, inv.º 402] [provenance: Manor of Santar]	1695	<i>Barco F. 1695</i>
	Lisboa, Palace of Domingos Dantas da Cunha, garden in Torel	1695	[disappeared] ²⁸
	Lisboa, Palace of Independência	1696	<i>Gabriel d(...) G^{el} Barco.</i>
	Lisboa, Museum of São Roque [provenance: house in Largo do Terreiro do Trigo]	1697	<i>G. B^{co} 1697</i>
	Lisboa, Palace of Condes da Ponte	1697	<i>G.^{el} del Barco F. / 1697</i>
	Beja, Church of Nossa Senhora dos Prazeres	1698	<i>G.^{el} B.^c F. / 1698</i>
	Lisboa, House in Calçada dos Cavaleiros	1698	[location unknown] ²⁹
	Évora, Church of São Tiago	1699	<i>Gabriel del / Barco F. / 1699</i>
	Lisboa, Church of São Bartolomeu da Charneca do Lumiar	1699	<i>G.^{el} B.^{co} F. / 1699</i>
	Évora, Church of São Mamede, room of the Brotherhood of Blessed Sacrament	1699 [?]	<i>Gabriel barco fez / na era de 1699 [?] (...) // [...] qua (...) / esta</i>
	Arraiolos, Church of the former Convent of Lóios	1699 - 1700	<i>(...) Briel del / (...)arco F 1699 GABRIEL DEL / BARCO F.</i>
Lisboa, house in São Bento area [MNAz, inv. 373 e 373A]	1700	<i>Gabriel del / Barco F. 1700</i>	
Garcia Ramires	Lisboa, azulejo of single figure [MNAz, inv. 384] [provenance: former Convent of Francesinhas]	1691	<i>GARCIA RAMIREs / ERA de 1691 a</i>

Table 3: Late 17th century signatures

Painter	Place	Date	Signature
Raimundo do Couto	Lisboa, Palace of Marquês de Tancos		<i>Rm. Docotto / fecit</i>
António Pereira	Brazil, Recife, Golden Chapel of Ordem Terceira de São Francisco	1702 - 1703	<i>An.^{to} p.^{ra} Fec.</i>
	Brazil, Salvador, Palace Saldanha		<i>An.^{to} p.^{ra} f.ct</i>
	Vidigueira, Church of Misericórdia		<i>An.^{to} p.^{ra} f.</i>
António de Oliveira Bernardes	Évora, Church of the Convent of São João Evangelista [Lóios]	1711	<i>Antonius ab oliva fecit. 1711</i>
	Ponta Delgada, Church of the Monastery of Esperança, lower choir and dormitory	1712	<i>An.^{to} deoliu^{ra} Bd.^{es} / fecit ra Bernd.^{es} / de 1712</i>
	Lisboa, Church of São Domingos de Benfica		<i>An.^{to} doliueira / berd.^{es} fecit.</i>
	Braga, Cathedral, Chapel of São Pedro de Rates		<i>An.^{to} doliu^{ra} Bernd.^{es} f.</i>
	Braga, Convent of Pópulo, Chapel of Santa Apolónia		<i>Antonius aboliua / inuentor</i>
	Peniche, Sanctuary of Nossa Senhora dos Remédios		<i>Antonius Aboliua B (...) / des, fecitt.</i>
	Évora, Church of Nossa Senhora da Cabeça		<i>An.^{to} deolv.^{ra} Bd.^{es} ofes.</i>
	Aldeia da Serra, Convent of Eremitas de São Paulo da Serra d'Ossa, former Chapel of the Bishop		<i>An.^{to} deoliu^{ra} Bernd.^{es} / fecit.</i>
Master P.M.P.	Estate of São José do Marco [provenance: former Convent of Nossa Senhora da Subserra]	1713	<i>P.M.P.</i>
	Barcelos, Church of Terço, main chapel	c.1713	<i>P.M.P.</i>
	Setúbal, House of Corpo Santo	c.1714	<i>P.M.P.</i>
Manuel dos Santos	Évora, former Convent of Espinheiro, Chapel of Senhor Morto	c.1710	<i>m.^{el} Dossan / to[s] o fes</i>
	Olivença, Church of Misericórdia	1723	<i>Pintou o M.^{el} dossantos. / Anno de 1723</i>
	Lisboa, Convent of São Bartolomeu do Beato		<i>De M.^{el} DosSantos</i>
S. Pedro [?]	Coimbra, azulejos from the former College of São Pedro dos Religiosos Terceiros ³⁰	1707	<i>S. PEDRO / PINTOR / SOV EV</i>

Table 4: Signatures of the *Masters' Cycle* painters

Painter	Place	Date	Signature
Policarpo de Oliveira Bernardes	Viana do Castelo, Church of Misericórdia	1719 -1721	<i>Policar / pus, / oliua / fecit.</i>
	Braga, Church of Penha de França	<1727	<i>Policarpus aboli / ua fecit</i>
	Almancil, Church of São Lourenço	1730	<i>POLICARPO DE /OLIVEIRA BER^{es}/ Pintou esta obra de azu / leio</i>
	Setúbal, Fort of São Filipe	1736	<i>Policarpus aBoliua Be.^{des} Fecit, 1736.</i>
	Porto Salvo, Chapel	1740	<i>Esta obra mandarão fazer os devotos de Lisboa Noanno de 1740 por P. D. Ber.^{des}</i>
	Viana do Castelo, Manor Barbosa Maciel (Museum), chapel		<i>Policarpo aboliva bdes pinxit</i>
	Vila Viçosa, Church of Nossa Senhora da Conceição		<i>Policarpo Deoliueira Bern</i>
Teotónio dos Santos	Grândola, Church of Misericórdia		<i>Policarpodeoliueyra Bernardes o fes,</i>
	Viana do Castelo, Church of São Bento		<i>Theot.io dos S. tos I o Pintou</i>
Gualter	Sátão, Sanctuary of Nossa Senhora da Esperança		<i>theotonio dossantos opintou em Lx.^a</i>
	Panel depicting Santa Brígida, in Museu Grão Vasco	1729	<i>S. BRIZIDA / G^{ter} ME F 1729</i>
Nicolau de Freitas	Braga, Church of Terceiros de São Francisco	1734	<i>Nicolao de Freytas a fes / no anno de 1734</i>
	Vilar de Frades, Church of former Convent, Chapel of Nascimento	1736	<i>Nicolao de Freitas, a Pintou.</i>
	Funchal, Church of Recolhimento do Bom Jesus, panel on main chapel façade	1744	<i>N. S. do Monte do Carmo / Nicolao de Freytas Pintou Em Lx^a no anno / de 1744</i>
Joaquim José Monteiro de Faria	[mentioned by Santos Simões ³¹ panel depicting Saint Anthony, for sale in Holland in 1949]	1740	<i>IOAqVIM:IOZE:MONT^{ro}: DE FArIA:0 FES:EM / Lx^a: A 20 = DE YANEIrO: DE = 1740 / S:ANTONIO</i>

Table 5: Signatures of the *Great Joanine Production's* painters

Tiler	Place	Date	Signature
Bartolomeu Antunes	Vilar de Frades, Church of former Convent, Chapel of Almas	1736	<i>Bartholomeu Antunes a fes em Lix.^a no anno de 1.7.3.6.</i>
	Matacães (Torres Vedras), Church of Nossa Senhora da Oliveira	1736	<i>B.^{meu} Antunes / a fes em Lix.^a Na era de / 17.3.6</i>
	Brazil, Salvador, Convent of São Francisco, main chapel	1737	<i>B.^{meu} Antunes / a fes nas olarias / em Lx.^a no de 1737</i>
	Porto, Church of São João Novo, Chapel of Santa Rita	1741	<i>B.^{meu} Antunes / a fes en Lx.^a nas / Olarias no anno de 1741</i>
	Vilar de Frades, Church of former Convent, Chapel of Conceição	1742	<i>Bartholomeu Antunes / a fes em Lx.^a nas olarias / no anno de. 1742</i>

Table 6: Tilers' signatures

Considering the contents of the signatures (see tables 3 to 6), note that all indicated their names mainly abbreviating first names and surnames. Only Policarpo de Oliveira Bernardes signs his full name at least once (Grândola, Misericórdia Church). It is also in this workshop that signatures with Latinized names appear for the first and only time in Portuguese tiles, with three and four examples, respectively, for António de Oliveira Bernardes and Policarpo de Oliveira Bernardes. It should be noted that whilst António never Latinizes the surname Bernardes, reducing his name to *Antonius aboliva*, his son uses the same formula –*Policarpus olive* – but also other variants that include the surname.

In the signatures of Portuguese tile painters from the late 17th and early 18th centuries, the general option was to use cursive, with only three cases of full capitalization of names: Gabriel del Barco at Lóios Convent in Arraiolos – *GABRIEL DEL / BARCO F.* (fig. 1); Garcia Ramires' tile – *GARCIA RAMIREs / ERA de 1691 a;* and Policarpo de Oliveira Bernardes in the Church of São Lourenço, in Almancil – *POLICARPO DE OLIVEIRA BERdes / Pintou esta obra de azuleio*³².

Unfortunately, the absence of precise dates does not allow conclusions on the changes in the way signatures were made by the same artist during his life, which would imply a meaning that escapes us. Even in the case of Gabriel del Barco, with sixteen signatures in twelve years, there seems to be no consistency in the alterations, which alternate between abbreviations and full names, although the latter option predominates since 1699 (with four examples out of five). On the other hand, in the case of large figurative compositions, there does not seem to be a direct link between the available space and the abbreviations or the use of the full names of the painters. In fact, there is only one signature inscribed in a "space" not made by the painter, in the Church of São Tiago, in Évora. There, the space available at the base of a column is relatively small, but this did not prevent Barco from writing his full name.

These authorial marks were complemented by further information, and it was possible to identify only three cases without a complement³³, and the signatures of Master P.M.P., that only exhibits these initials. It is worth noting, however, that there are examples by Gabriel del Barco,

such as in São Victor Church in Braga, where changes to the original covering are perceptible, thus truncating the signatures, which prevents their global reading and interpretation.

The date of each work, which is restricted to the year, is very frequent, appearing in thirty-one of the sixty-six cases analysed. However, whilst Gabriel del Barco indicates the date in most of his signatures (12), António and Policarpo de Oliveira Bernardes are more restrained in using this complement, both indicating the year in only two coverings each. More sporadically, the year may be preceded by “*era de*”, “*na era de*”, “*anno de*”, “*no anno de*” (the age of, in the age of, year of, in the year of). An interesting aspect to underline here is the use of the expression “*era*”, possibly as a way of conferring solemnity to these signatures since this expression was no longer used in Portugal since the late Middle Age.



Fig. 5: António de Oliveira Bernardes, Braga, Church of Pópulo Convent, Chapel of Santa Apolónia

The use of verbs indicative of an action, e.g. relating to the involvement of the painter in each *azulejo* covering, are the most common signature complement, but with very different forms. The most usual refers to the verb *fecit*, which may appear in the form of an abbreviation –“*f.*”, “*F.ct*”– and, in Portuguese – “*o fes*” or “*a fes*”³⁴. However, Gabriel del Barco never uses the word “*fecit*” unabbreviated, as does Antonio Pereira.

Particularly interesting are the expressions used more rarely: António de Oliveira Bernardes, in the Chapel of Santa Apolónia (Church of Pópulo Convent, Braga), adds to his Latinized name the expression “*inventor*” (fig. 5); Manuel dos Santos, in Misericórdia Church in Olivença, indicates “*Pintou o M.^{el} dossantos*” (painted by Manuel dos Santos); Teotónio dos Santos ends the signature always with the expression “*o pintou*” (painted it); and Nicolau de Freitas opts for this last solution in Vilar de Frades – “*a Pintou*”.

Another case is that of Policarpo de Oliveira Bernardes, who in Almancil declares that he “*Pintou esta obra de azulejo*” (painted this tilework) and in Viana do Castelo, in the Barbosa Maciel House, adds “*pinxit*” to his name.

The use of the expressions “*pintou*” (painted) seems to be explicit about the work done in a certain covering, and the apposition of these complements is quite revealing of the need to clarify who did what. To this extent, the hypothesis that António de Oliveira Bernardes' use of the expression “*inventor*” may indicate that in the case of the representation of the two moments of the life of Santa Apolónia, Bernardes was not only the painter but also the author of the compositions, in the sense that he did not copy or use engravings as a source of inspiration, a procedure that was quite usual among tile painters in Portugal.

On the other hand, while Manuel dos Santos, in Convent of Beato in Lisbon uses the expression “*De*” (of), certainly as a way of expressing his authorship, Gabriel del Barco precedes his name by a capital “*D.*” in the Chapel of Estate of Nossa Senhora da Conceição in Barcarena (Oeiras) – “*D. Gabriel del / Barco F. 1691*”. Perhaps it was a synonymous of “*Dom*” and the way male

Spaniards were treated in Portugal until very late, regardless of whether they were noble or not, therefore between them, and in a formal way, they used "D." before the name.

Finally, it is important to mention the place where the work was performed, which appears in one of the signatures of Teotónio dos Santos, in the Sanctuary of Nossa Senhora da Esperança, in Sátão— "*theotonio dossantos opintou em Lx.*"³⁵ –, and more frequently associated with the tiler Bartolomeu Antunes. In fact, in the Church of São João Novo, in Oporto, and in the Church of the Convent of Vilar de Frades, he even goes so far as to indicate the place of the city – "*Bartolomeu Antunes a fes em Lx.a nas olarias(...)*". By observing other artistic modalities, for example, funerary art, the indication of the place had a clear advertising purpose. At that time, when there were no toponymic plaques or police numbers, an indication of a name and a city was sufficient for anyone interested in similar works to send a letter to Lisbon to an agent who sought the artist³⁶. It was surely not by chance that the indication of the place where the work was executed appears more often associated with a tiler, who certainly negotiated also with non-figurative *azulejos* and, as such, without any signature.

As regards the place of signatures in the compositions, it should be noted that in a number of cases the coverings were removed from their original sites or were significantly altered, which makes a consistent analysis impossible. This difficulty is particularly evident in the case of Gabriel del Barco who, considering the coverings still conserved in situ without apparent alterations, seems to have chosen discreet placements, which explains why some of these signatures have only recently been discovered. Looking at the set of signatures of the Spanish painter, one can notice that he often "opened" a space in the landscape, usually near the ground, or took advantage of an architectural element to inscribe his name. There is also the interesting case of the Room of the Blessed Sacrament in São Mamede Church, Évora, in which he used a roof to write a practically unintelligible phrase – "*Gabriel barco fez / na era de 1699 (?) (...) / (...) qua (...) / est*". These are examples of signatures in "unforeseen"³⁷ or epigraphic³⁸ places, as occurs in the Church of São Tiago, also in Évora.

In fact, as it happened in canvas painting, most painters have opted to place the signature on the lower part of the compositions, which means that, in a covering, these marks remain close to the floor, although they may be prominent within the composition. However, if we consider that inside the churches the faithful would be kneeling or sitting on the floor, this positioning is not random or inconsequential.

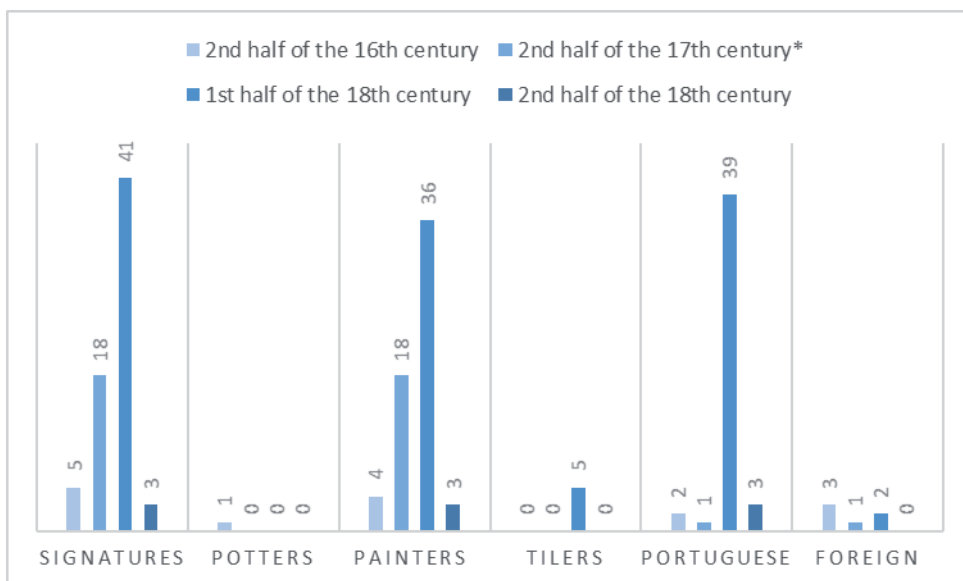
In other cases, as in the transept of the Church of São Domingos de Benfica, the signature of António de Oliveira Bernardes is slightly above eye level, but the fact that it is painted in blue over a blue background makes his name more imperceptible, a situation that is repeated in the chapel of São Paulo Convent in Serra d'Ossa. However, this is one of the painters who seems to have positioned his signature very carefully, making it visible and well readable, in an option that his son, Policarpo de Oliveira Bernardes, will accentuate even more. On the other hand, as Niculoso Francisco, António de Oliveira Bernardes is the only one to place a signature outside the figurative composition space, opting to highlight his name even more when he places it in the chapel of Santa Apolónia (Pópulo Convent, Braga) inscribed in a cartouche on the frame, in the axis of one of the doors (fig. 5). This fact allied to the expression "*inventor*", already mentioned, reinforces the importance that the painter gave to this work.

Finally, it is important to highlight the complementarity between signatures in the same space, as happens in Chapel of Nascimento, in Vilar de Frades, where the painter's signatures in front of the tiler's: *Bartolomeu Antunes a fes em Lix.^a no anno de 1736 | Nicolao de Freitas, a Pintou.*

DISCUSSION AND FINAL SYNTHESIS

The present study is part of the research perspectives we have been developing related to the definition of the tasks of each agent in a tilework commission. However, rather than seeking to understand how the painter is organized and articulated with the other agents, we are interested in systematizing issues related to signatures on ceramic tiles, in order to be able to associate a series of questions for future discussion.

As we have seen along these pages, the signatures or the authorial marks are, as expected, only associated with figurative coverings: in a first stage only with imported tiles and what is conventionally designated as the first Portuguese production, in the Mannerist taste; and, already in the last quarter of 17th century, related to the great narrative cycles executed in blue and white colours (see graphics 1 and 2).



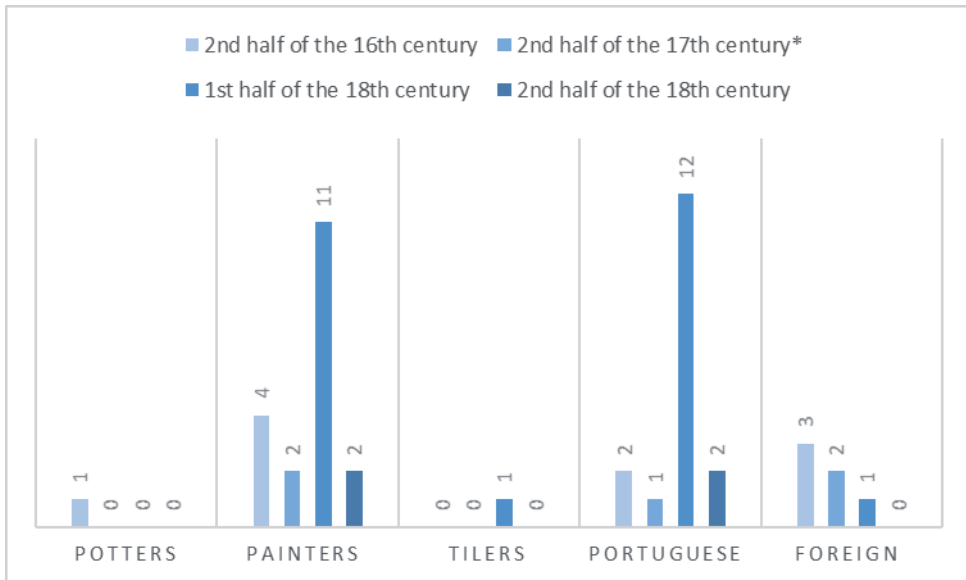
Graphic 1: Signatures overview showing the total number of signatures organized by centuries

* There are also monograms in Quinta do Calhariz, dating from 1672, but their location does not allow us to see if it is a signature or a trademark featuring a box³⁹.

The older marks – the monograms – are certainly rooted in a tradition linked to Northern Europe, and the names of the authors are progressively unfolded. At the end of the 17th century, Gabriel del Barco signed a large number of coverings, and he is the painter with more works associated to his signature, using different variants. Like the painters of the next cycle, known as the *Masters’ Cycle*, the assumption of an authorial mark and the desire for authorship recognition seems obvious. If the so-called Master P.M.P. seems to use only an acronym almost as if it were a stamp, others use the handwriting closest to the signatures that can be compared with archival documents. Still others, such as the Bernardes family, Latinize the names and surnames, certainly as a form of association with classical and Roman tradition and a more erudite universe, exemplified by the “*pinxit*” expression used by Policarpo in Viana do Castelo (fig. 4) or, more generalized, the Latin form of *facere – fecit*.

In the context of the Portuguese Mannerist painting of the 16th and 17th centuries (1570-1630), the defence of the liberality of painting and the pantry of the obligations from the mechanical

craftsmen related to the “Bandeira de São Jorge” was a victory of the oil painters, under the protests of the painters of tempera and gilders, who sought the same ascent and perks⁴⁰. This created a distance between more erudite painting and another type linked to the decorative arts, which existed in theoretical terms but which could hardly be a practical reality, as can be seen for example in the documentation of the Brotherhood of St. Lucas, whose deed of undertaking allowed the entry of all those who dedicated themselves to the drawing⁴¹.



Graphic 2: Signatures overview organized by number of potters, painters and tilers who signed their works and by their nationality

From the second third of the 17th century these movements enter in a period of reflux and the defence of the liberality of painting "will be only laudatory", coinciding also with a period of greater number of commissions from gilding and “*brutesco*” painters to the detriment of oil painters⁴².

At the end of the century two events again marked the artistic environment in Portugal, now with direct consequences on the *azulejo* painting. On 14 May 1689, D. Pedro II promulgated a law in favour of painting and sculpture⁴³, "(...) excluding them from the status of mechanical craft and any “bandeira”, at the same time that he considered the art they exercised to be noble⁴⁴. It is a position that relates to broader political decision-making over who is noble⁴⁵.

The question that arises here is to see in what arena the tile painters moved, especially those who also engaged in other artistic modalities, including oil painting. Let us not forget all the attributes, so well expressed by Félix da Costa, that defined a painter, in which drawing stands out, considering that tile painters who do not know how to draw do not deserve to call themselves painters⁴⁶. Years later Cirilo Volkmar Machado (1748-1823) ignores the tile painters (with the exception of Manuel António de Góis (1730-1790)), considering them unworthy to be called painters, not even referring to António de Oliveira Bernardes⁴⁷.

Thus, the signatures must be understood in this specific context in which recognizing the social status of the *azulejo* painters is difficult. In addition, they should be understood as a claim for recognition of an authorial mark, which distances the painters from the anonymous craftsmen,

to which they would be tied, even by the characteristics of the *azulejos* production, which requires the *mechanical* knowledge of the potter and the tiler⁴⁸. However, it should be taken in consideration that at this time painters practiced different modalities, certainly as a skilful market strategy, to cope with a precarious situation. António de Oliveira Bernardes is the painter who is undoubtedly known to have practiced painting on easel, ceilings and *azulejos*, although he rarely combined them within the same space/work⁴⁹, in a situation common to several painters of oil and tempera⁵⁰.

The second event referred to above is the promulgation of protectionist measures by the Council of State substantially on these dates, and known as the edicts of the Lisbon Customs. Thus, on 7 August 1687, but with Customs registration on November 10, it was forbidden to bring in crockery and tiles from outside the kingdom, a restriction that was in force for about twelve years and was lifted in April 1698⁵¹. It has been interpreted as an incentive for the production of national tiles, as part of a broader protectionist policy, and a stimulus for painters of other genres to also dedicate themselves to tiles⁵².

Thus, it was not by chance that the first *azulejo* covering that is known signed by Gabriel del Barco dates back to 1689. Knowing that he painted in other artistic genres, there are no other works signed by him except *azulejos*, a situation that is repeated, although with occasional exceptions, in the case of António de Oliveira Bernardes. Although historiography insists that from 1700 onwards Bernardes was dedicated exclusively to tiles, known documents and works reveal that in his workshop different genres were practiced at the same time, but the *azulejo* was the privileged support for associating authorial marks.

Social recognition sought by the *azulejo* painters of the Baroque period contextualizes and may explain to a certain extent the number of signatures identified⁵³, but it does not answer other more specific questions and, in particular, the evidence of which only a very small number of works are signed. Which reasons justify the displaying of the signature in certain coverings to the detriment of others? Was it a selection determined by the importance of the work in the context of a workshop / painter? André Gonçalves, who was a disciple of António de Oliveira Bernardes, argued that only "invented" works should be signed, thus leaving out those that were inspired by engravings⁵⁴. However, we easily identify the engravings that were used as the basis for signed coverings. On the other hand, although a systematic study on signatures in contemporary painting is lacking, the work of António de Oliveira Bernardes shows a single signature on a canvas, in Viana do Castelo – *Antonius aboliva Bernardes fecit* –, dated 1719⁵⁵.

Is it possible to draw a geographical profile of signatures, understanding that they arise in strategic locations and may be directly related to issues of "advertising", as we have already defended elsewhere⁵⁶? To this extent, by clearly identifying the author of the *azulejos* the signatures would serve as a way to make known the work of a certain painter, particularly far from the region where he had his workshop, paving the way for the appearance of new and more commissions. The signatures of the master tilers, of which Bartolomeu Antunes is an example, can be interpreted likewise.

In any case, it seems indisputable that the apposition of a signature corresponds to the claim of individual authorship, which, in the context of the history of Portuguese tiles, explains why these arise in periods of accentuated and erudite narratives. This is particularly visible in the *Masters' Cycle*, when the painters played in various arenas – oil painting and the decorative arts, which included the *azulejo* with very strong and indispensable relations with the world of potters and tilers.

As the 18th century progresses, the signed works are in much smaller number and interestingly all the few signers were disciples of António de Oliveira Bernardes. In fact, the cycle of the so-called *Great Joanine Production* did not favour the individualization of painting, and in the

mid-18th century signatures tended to disappear from Portuguese *azulejos*. The 1755 earthquake marked a return to patterned tiles and, in the context of Real Fábrica de Louça, ao Rato (1767-1835), figurative production does not seem to have been signed, and no authorship marks in the second half of the century are known, although we recognize the rise of Sebastião de Almeida (1727-1779) as artistic director of Fábrica do Rato and the relevance that Francisco de Paula e Oliveira conferred on drawing, which he learned at his own expense⁵⁷. The only exception is the Coimbra production and the work signed by Salvador de Sousa Carvalho⁵⁸ (table 7) as well as the *azulejos* that cover the main chapel of the Sanctuary of Milagres (Leiria), executed in 1795. The painter José Rodrigues da Silva e Sousa (?-1824), from Fábrica do Juncal, left an indication of authorship at the end of the history about the sanctuary built by his grandfather, José da Silva: "*E eu Jozé Roiz da Silva e Souza, neto do dito mestre Joze da Silva, fis este azuleijo e o mandei aqui colocar na Era de 1795*"⁵⁹.

Painter	Place	Data	Signature
Salvador de Sousa Carvalho	Museu Nacional Machado de Castro, provenance: Monastery of Santa Maria de Semide	1784	<i>No anno de 1784 fes Sousa Carvalho</i>
	Coimbra, Casa-Museu Bissaya Barreto, entrance hall	1780-1790	<i>Salvador de Çousa</i>
José Rodrigues da Silva e Sousa	Leiria, Sanctuary of Milagres, main chapel	1795	<i>E eu Jozé Roiz da Silva e Souza, neto do dito mestre Joze da Silva, fis este azuleijo e o mandei aqui colocar na Era de 1795</i>

Table 7: Salvador de Sousa Carvalho signatures

Concluding, in spite of the different questions that still require an answer and concerning the situation of painters as well as the recognition of painting as a liberal art, the apposition of the signatures observed is indicative of an authorial intention, and reveals an attitude towards the work, whether is it conscious or not of an artistic personality. On the other hand, and as we stated, this article aims to systematize the known signatures on *azulejos* of the first Portuguese majolica production and the Baroque period, but broader research is required in which the comparison with the signatures and authorship marks present on tiles produced in other European centres is crucial.

Acknowledgments

This study was funded by Fundação para a Ciência e Tecnologia (FCT-Portugal) with a postdoctoral grant (SFRH/BPD/84867/2012) owned by the first author, supported by the European Social Fund through the Human Capital Operational Programme (HCOP), and by national funds from the Ministry of Science, Technology and Higher Education.

Bibliographic references

¹ TELLES, Liberato – *Duas palavras sobre pavimentos*. Typographia da Companhia Nacional Editora, Lisboa, 1896.

² QUEIRÓS, José – *Cerâmica Portuguesa e outros estudos*. 4ª ed. Lisboa: Editorial Presença, 2002 [1907].

³ CORREIA, Vergílio – *Azulejos*. Livraria Gonçalves, Coimbra, 1956. Publicação original da obra *Azulejos Datados em 1916 e 1922*.

⁴ GILBERT, Creighton – *A preface to signatures (with some cases in Venice)*. *Fashioning Identities in Renaissance Art*, edited by Mary Rogers, Ashgate, 2000, 79-87.

⁵ LEBENSZTEJN, Jean-Claude - *Esquisse d'une typologie*. *Revue de l'Art*, n. 26, 1974, 46-56.

⁶ CALABRESE, Omar; GIGANTE, Betty – *La signature du peintre*. *Part de l'oeil*, n. 5 1989, 27-43.

⁷ RUBIN, Patricia – *Signposts of Invention: Artists' Signatures in Italian Renaissance Art*. *Art History*, n. 29, 2006, 563-599.

⁸ RUBIN, Patricia – *Signposts of Invention: Artists' Signatures in Italian Renaissance Art*. *Art History*, n. 29, 2006, 571.

⁹This study includes a psychological approach, based on the same methodologies used by graphologists and forensic experts, in order to complement the traditional procedures of Art History.

¹⁰ See <https://azinfinitum.wixsite.com/signatures>

¹¹It is worth mentioning that many are recognizable in models that circulated in architectural treaties.

¹² LEBENSZTEJN, Jean-Claude - *Esquisse d'une typologie*. *Revue de l'Art*, n. 26, 1974, 46-56.

¹³ CHASTEL, André – *Signature and signe*. *Revue de l'Art*, n. 26, 1974, 8-14. Note that it might be more appropriate to opt for a terminology such as "author inscriptions", but in this case there would be many other aspects that are outside the scope of this study, which is why we chose to use "signatures".

¹⁴ Following the studies of Alfonso Pleguezuelo we opted to use the name Niculoso Francisco Pisano. However, the Union List of Artist Names (ULAN), developed by The Getty Research Institute, has Francisco Niculoso as preferred.

¹⁵ SENOS, Nuno – *Os lugares dos azulejos*. Da Flandres. Os azulejos encomendados por D. Teodósio I, 5º Duque de Bragança (c. 1510-1563), Museu Nacional do Azulejo, Lisboa, 2012, 30-41; PAIS, Alexandre Nobre – *Reminiscências de uma memória esquecida: os azulejos flamengos quinhentistas para o Paço Ducal de Vila Viçosa*. Da Flandres. Os azulejos encomendados por D. Teodósio I, 5º Duque de Bragança (c. 1510-1563), Museu Nacional do Azulejo, Lisboa, 2012, 42-57.

¹⁶ SIMÕES, João Miguel dos Santos – *Os Azulejos do Paço de Vila Viçosa*. Fundação da Casa de Bragança, Lisboa, 1946.

¹⁷ SIMÕES, João Miguel dos Santos – *Os Azulejos do Paço de Vila Viçosa*. Fundação da Casa de Bragança, Lisboa, 1946, 45.

¹⁸ DUMORTIER, Claire – *Contribution à l'étude des carreaux anversois de Vila Viçosa*. *Azulejo*, n. 1, 1991, 30-31.

¹⁹ DUMORTIER, Claire – *Contribution à l'étude des carreaux anversois de Vila Viçosa*. *Azulejo*, n. 1, 1991, 32.

- ²⁰ PAIS, Alexandre; MIMOSO, João Manuel; DUMORTIER, Claire; ESTEVES, Maria de Lurdes; SILVA, Miguel Angelo; PEREIRA, Sílvia – *Graça Church revisited / A Igreja da Graça revisitada*. GlazeArch2015 – International Conference Glazed Ceramics in Architectural Heritage, Lisbon: LNEC - Laboratório Nacional de Engenharia Civil / Museu Nacional do Azulejo, Lisbon, 2015, 35-40.
- ²¹ BILOU, Francisco Teófilo Alfaiate – *Alguns artistas estrangeiros residentes em Portugal (1550-1640). Notas documentais colhidas nos Processos da Inquisição de Lisboa*. Cadernos de História da Arte, n.1, 2013, 93.
- ²² CARVALHO, Rosário Salema de; MANGUCCI, Celso – *Quem faz o quê: a produção de azulejos na época moderna (séculos XVI a XVIII)*. ARTis ON, n. 6, 2018: 8-24.
- ²³ JUREN, Vladimir – *Pratique artisanale du Nord. La signature épographique. Fecit Faciebat*. Revue de l'Art, n. 26, 1974, 21-23.
- ²⁴ TEIXEIRA, Céline Ventura – *Quinta da Bacalhôa / Bacalhôa Estate*. Azulejos – Maravilhas de Portugal / Wonders of Portugal, editado por Rosário Salema de Carvalho. Centro Atlântico, Vila Nova de Famalicão, 2017, 291–297.
- ²⁵ PERROT, Françoise – *La signature emblématique. La signature imprévue. La signature des peintres verriers*. Revue de l'Art, n. 26, 1974, 33-39. It is worth noting that the monogram on the tile covering from Convent of Graça could not correspond to its original location as stated in endnote 18.
- ²⁶ QUEIRÓS, José – *Cerâmica Portuguesa e outros estudos*. 4^a ed. Lisboa: Editorial Presença, 2002 [1907], 239.
- ²⁷ SERRÃO, Vitor – *António Pereira Ravasco, ou a influência francesa na arte do tempo de D. Pedro II*. A Cripto-História de Arte. Livros Horizonte, Lisboa, 2001, 125-148.
- ²⁸ MECO, José – *O pintor de azulejos Gabriel del Barco*. História e Sociedade, n. 6, 1979, 58–67.
- ²⁹ MECO, José – *O pintor de azulejos Gabriel del Barco*. História e Sociedade, n. 6, 1979, 58–67.
- ³⁰ CORREIA, Vergílio; GONÇALVES, António Nogueira – *Inventário Artístico de Portugal - Cidade de Coimbra*. Vol. II. Lisboa: Academia Nacional de Belas Artes, 1947, 153.
- ³¹ SIMÕES, João Miguel dos Santos; CÂMARA, Maria Alexandra Trindade Gago da Câmara, ed. – *Azulejaria em Portugal no século XVIII*. Ed rev. e actualiz. Fundação Calouste Gulbenkian, Lisboa, 2010, 29.
- ³² The tiles “authored” by S. Pedro and Joaquim José Monteiro de Faria, mentioned by Santos Simões were also capitalized.
- ³³ The case of Policarpo de Oliveira Bernardes in Vila Viçosa and Porto Salvo, the last with a previous and different complement, and Salvador de Sousa Carvalho in Semide.
- ³⁴ It is worth noting that both expressions are of different genders in Portuguese: “o fes” is of male gender and probably refers to the *azulejo* covering whilst “a fes” is of female gender and probably refers to the painting. The same happens with the expressions “o pintou” and “a pintou”.
- ³⁵ This signature was wrote in white colour over the original, in blue, as can be seen when observing the *azulejos*.
- ³⁶ QUEIROZ, José Francisco Ferreira - *Os Cemitérios do Porto e a arte funerária oitocentista em Portugal. Consolidação da vivência romântica na perpetuação da memória*. PhD thesis, Faculdade de Letras da Universidade do Porto, 2002, vol. 1, tomo I, 778; 802-803.

³⁷ PERROT, Françoise – *La signature emblématique. La signature imprévue. La signature des peintres verriers*. Revue de l'Art, n. 26, 1974, 31-37.

³⁸ JUREN, Vladimir – *Pratique artisanale du Nord. La signature épigraphique. Fecit Faciebat*. Revue de l'Art, n. 26, 1974, 24-26.

³⁹ CARVALHO, Rosário Salema de – *A pintura do azulejo em Portugal [1675-1725]: autorias e biografias - um novo paradigma*. PhD thesis, Faculdade de Letras da Universidade de Lisboa, 2012, 159. <http://repositorio.ul.pt/handle/10451/6527>.

⁴⁰ SERRÃO, Vitor – *O maneirismo e o estatuto social dos pintores Portugueses*. Imprensa-Nacional Casa da Moeda, Lisboa, 1983; CARVALHO, Rosário Salema de; MANGUCCI, Celso – *Quem faz o quê: a produção de azulejos na época moderna (séculos XVI a XVIII)*. ARTis ON, n. 6, 2018: 20.

⁴¹ FLOR, Susana Varela; FLOR, Pedro – *Pintores de Lisboa Séculos XVII-XVIII A Irmandade de S. Lucas*. Scribe, Lisboa, 2016.

⁴² SERRÃO, Vitor – *O maneirismo e o estatuto social dos pintores Portugueses*. Imprensa-Nacional Casa da Moeda, Lisboa, 1983, 258-259.

⁴³ COSTA, Felix da – *The Antiquity of the Art of Painting by Felix da Costa [1696]*, Introduction and Notes by KUBLER, George, Yale University Press, New Haven and London, 1967, 222, 228-234. See also FLOR, Susana Varela; FLOR, Pedro – *Pintores de Lisboa Séculos XVII-XVIII A Irmandade de S. Lucas*. Scribe, Lisboa, 2016 and SOBRAL, Luís de Moura - *Pintura portuguesa em Faro numa Época de Crise*, 2018, in press (we thank the author for allowing us to read the article before it was published).

⁴⁴ COSTA, Felix da – *The Antiquity of the Art of Painting by Felix da Costa [1696]*, Introduction and Notes by KUBLER, George, Yale University Press, New Haven and London, 1967, 225.

⁴⁵ SALDANHA, Nuno – *Poéticas da Imagem. A Pintura nas Ideias Estéticas da Idade Moderna*. Editorial Caminho, Lisboa, 1995.

⁴⁶ COSTA, Felix da – *The Antiquity of the Art of Painting by Felix da Costa [1696]*, Introduction and Notes by KUBLER, George, Yale University Press, New Haven and London, 1967, 70r.

⁴⁷ MANGUCCI, Celso – *Um esquecimento premeditado. Cirilo Volkmar Machado e a historiografia da azulejaria portuguesa*. ARTIS - Revista de História da Arte e Ciências do Património, 4, 2016, 28-33.

⁴⁸ However, it is worth mentioning that the painter who, in 1747, made the *azulejos* for the Room of Definitório of the Brotherhood of Clérigos Pobres, in Church of São Pedro (Torres Vedras) used an engraving to compose one of the figurative panels, also copying the signatures on it – *Author Invent Claud. Coell. Delin. Fran. Houat. Sculp.* Ou seja, o pintor espanhol Claudio Coello (1642-1693) foi o autor da composição e o gravador Francisco Houat. Cf. PEREIRA, Gabriel – *Pelos suburbios e visinhanças de Lisboa*. Livraria Clássica Editora, Lisboa, 293; QUEIROZ, José – *Louça e Azulejos de Torres Vedras*. Terra portuguesa: revista ilustrada de arqueologia artística e etnografia, ano 1, n. 2, Março de 1916, 47; SIMÕES, João Miguel dos Santos; CÂMARA, Maria Alexandra Trindade Gago da Câmara, ed. – *Azulejaria em Portugal no século XVIII*. Ed rev. e actualiz. Fundação Calouste Gulbenkian, Lisboa, 2010, 417.

⁴⁹ MANGUCCI, Celso – *A condição de autor nas campanhas de talha dourada e azulejo. Documentos para a história da Talha dourada e azulejo em Évora*. Arquivo Distrital de Évora, Évora, 2014, 18. <http://adevr.dglab.gov.pt/wp-content/uploads/sites/4/2014/11/link.pdf>.

-
- ⁵⁰ FLOR, Susana Varela; FLOR, Pedro – *Pintores de Lisboa Séculos XVII-XVIII A Irmandade de S. Lucas*. Scribe, Lisboa, 2016, 54-55, 61.
- ⁵¹ SIMÕES, João Miguel dos Santos – *Carreaux céramiques hollandais au Portugal et en Espagne*. Martinus Nijhoff, La Haye, 1959, 125-126.
- ⁵² FLOR, Susana Varela; FLOR, Pedro – *Pintores de Lisboa Séculos XVII-XVIII A Irmandade de S. Lucas*. Scribe, Lisboa, 2016, 40.
- ⁵³ CARVALHO, Rosário Salema de; MANGUCCI, Celso – *Quem faz o quê: a produção de azulejos na época moderna (séculos XVI a XVIII)*. ARTis ON, n. 6, 2018, 18-22.
- ⁵⁴ SALDANHA, Nuno – *André Gonçalves, pintor ingénuo ulissiponense (1685-1762)*, Vértice, n. 8, 61-71.
- ⁵⁵ RAIMUNDO, Pedro – A originalidade do Barroco português. *Jornal Voz das Misericórdias*, October 2008.
- ⁵⁶ CARVALHO, Rosário Salema de – *A pintura do azulejo em Portugal [1675-1725]: autorias e biografias - um novo paradigma*. PhD thesis, Faculdade de Letras da Universidade de Lisboa, 2012, 398-401. <http://repositorio.ul.pt/handle/10451/6527>.
- ⁵⁷ MANGUCCI, Celso – *Um esquecimento premeditado. Cirilo Volkmar Machado e a historiografia da azulejaria portuguesa*. ARTIS - Revista de História da Arte e Ciências do Património, 4, 2016, 28-33 and CARVALHO, Rosário Salema de; MANGUCCI, Celso – *Quem faz o quê: a produção de azulejos na época moderna (séculos XVI a XVIII)*. ARTis ON, n. 6, 2018: 8-24.
- ⁵⁸ Santos, Diana Teresa Fanha da Graça Gonçalves dos – *Azulejaria de fabrico coimbrão (1699-1801): artífices e artistas, cronologia, iconografia*. PhD thesis, Faculdade de Letras da Universidade do Porto, 2013. <https://repositorio-aberto.up.pt/handle/10216/72785>.
- ⁵⁹ MARTINS, Maria Filomena Silva – *Azulejos do Juncal: contributos para a história do azulejo em Portugal*. Diferença, Lisboa, 1997, 33, 138-156.

Pottery from Nishapur: Kunstwollen of Iranians

Anna Kholomeeva

*PhD student, The State Institute for Art Studies, Moscow, Russian Federation,
a.kholomeeva@gmail.com*

SUMMARY: The joining of the Iranian territories to the Caliphate and the spreading of Islam had a beneficial effect on the self-consciousness of Iranian artists. The result of this was the creation of the various types of designs and aesthetic effects of pottery production in the eastern Islamic lands of the IX-XI century. We are able to observe the variability of the principal stylistic features in Iranian pottery that are rooted in the fundamental changes under way in a certain society, its ideals, reappraisal of its values.

This research represents a study of the glazed Iranian pottery, mainly from Nishapur (north-eastern Iran), through the concept of artistic will, or volition - Kunstwollen.

It will be represented through examination of the several sources of inspiration for Iranian artists as ways of their perception of the outside world and a subsequent transformation of the received ideas as impelling impetus to a transformation in art.

KEY-WORDS: Iranian earthenware, ceramics from Nishapur, Kunstwollen Iranians', Kunstwollen, Iranian identity

INTRODUCTION

The joining of the Iranian territories to the Caliphate and the spreading of Islam had a beneficial effect on the self-consciousness of Iranian artists. The result of this was the creation of the various types of designs and aesthetic effects of pottery production in the eastern Islamic lands of the IX-XI century.

We are able to observe the variability of the principal stylistic features in Iranian pottery that are rooted in the fundamental changes under way in a certain society, its ideals, reappraisal of its values, proceeding the ideas of Alois Riegl and Hans Sedlmayr who are the bright representatives of Vienna School of Art History.

The aforementioned changes in the spirit of people came as a consequence of the Muslim conquest, and in turn led to the emergence of a variety of artistic motifs in ceramics. Muslim conquest was the event resulting in transformation of a way of life, thinking, abilities to understand themselves, and with it a local population's perception of the outside world. It is these changes in mindset, in turn, led to subsequent transformation of the received ideas from the different sources of inspiration as an impetus to a transformation in art.

It will be represented through the examination of the several sources of inspiration for Iranian artists as the ways of their perception of the world. The clarity and usefulness of such approach will be substantiated through a study of the glazed Iranian pottery, mainly from the city of Nishapur.

The present study is mainly based on the material discovered during the American excavations, organized by Metropolitan Museum of Art in the 1930s, and its subsequent publication by Ch.K. Wilkinson in 19731. In this edition, author examines a quantity of glazed and unglazed

earthenware excavated in the area of the city of Nishapur city. Ceramic items were divided into 12 groups mainly based on differences in technological features such as various types of glaze, engobe, colour scheme.

Furthermore, as it was indicated in aforementioned study, each technical peculiarity is associated with a particular stylistic solution and decorative motifs. It becomes evident, therefore, that there is a correlation between existing technology and aesthetic features of the item. In that regard, this study also aimed to find out whether the style of this pottery has resulted simply from a conjunction of available materials and current technology.

The recent excavations which occurred in the area of Nishapur by the Irano-French archaeological mission between 2004 and 2007 also gave the meaningful finds. The project and recent publication of the results² were aimed to refine the details concerning the foundation of the Nishapur on the one hand and to examine the ceramic production from the Sasanian times to the Mongol conquest on the other. Some results of this project will be presented in the following sections of the article.

KUNSTWOLLEN

As noted already, this research represents the study of the glazed Iranian pottery through the examination of the several sources of inspiration for Iranian artists as the ways of their perception of the outside world and the subsequent transformation of the received ideas as an impelling impetus to a transformation in art - in other words, through the concept of artistic will, or volition - Kunstwollen.

It is necessary to clarify what is meant by the concept of Kunstwollen. The term 'Kunstwollen' was first formulated by Alois Riegl within the theory of art in his 1893 monograph³ on the genesis and the nature of Ornament. According to him, the origin of various types of ornament should be looked for in the attitudes towards the world of the artists who made it. The concept of Kunstwollen is associated with the process about how something becomes a piece of art. It is important to note that this process is not an imitation of nature; in contrast, it is complicated procedure depending on the aesthetic feeling and mindsets of the generation of people.

In his following monograph⁴ (1901) the concept of Kunstwollen was regarded as an abstract feature of the period style cutting across different kinds of art. It represents a distinctive part of each period and a kind of period style.

With regard to the translation of the term 'Kunstwollen' it consists of 2 words: 'Kunst' which means 'art, science, skill, artistry' and 'wollen' – 'to want, to need, to be intended to'. The semantic meaning of this word therefore refers to the internal intention, the impulse to the art. In the view of absence of an accurate translation in English, it is appropriate to utilize the German version in order not to lose philosophical aspect of that issue.

In the view of the focus in this study on the art formation process, it is appropriate to examine certain historical and cultural conditions that surrounded the process of creation of ceramic items in Nishapur.

HISTORICAL AND GEOGRAPHICAL BACKGROUND

Nishapur was founded during the late 3rd century - early 4th centuries. According to some sources⁵, it was named after one of the Sasanian Kings Shapur I (3rd century) or Shapur II (4th century). But the results of recent excavations that were undertaken by the aforementioned Irano-French Mission suggest that the town was founded during the end of 4th century⁶.

The geographical position of the city made it a convenient and much frequented trading centre on the main caravan route leading to Fars, Kerman, Ray, Gurgan. Nishapur was located between

the mountains to the north and the desert to the south, forming a kind of a corridor for traders and people travelling from the areas of Minor Asia or Mesopotamia to Sogdia, India and China, and vice versa. In reference to this, it became clear that Yaqut, Arab scholar and geographer who was famous for his writings of the thirteenth century 'Dictionary of Countries', called Nishapur 'the gateway to the east'⁷.

Arabs broke into the city in the 7th century. Almost 100 years after the Arabic conquest, in the 8th century the eastern territories of the Caliphate began to gain a political semi-independence. Nishapur began to play a significant political and cultural role in the region. Furthermore, it gained in the importance as an intellectual and scientific centre for Arab elites. All the considered things became possible thanks to the arrival of the Abbasid dynasty in the Caliphate.

A point to bear in mind is that diversity of Nishapur's ceramics related to Islamic period was made not earlier than the Abbasid era⁸.

This state of affairs in conjunction with the mining of copper, iron, silver, turquoise created conditions for a rapidly developing pottery-making. As in the past, it was the most common type of handicraft in big cities. A thriving pottery production concerns to the late 9th – early 11th centuries. Incremental improvements of potter's wheels and kilns are presented as a legitimate process. On the contrary, the abundance of the different types of techniques and technologies, the elaboration of the different glaze's compositions, the appearance of innovations represents a different picture as a more complicated phenomenon. It is suggested that there was a strong impetus for such technological advances.

SOURCES OF INSPIRATION: CHINESE WORKS OF ART

Returning to the role of the Nishapur as 'the gateway to the east', it is important to note that one of the main sources of inspiration⁹ for Iranian artists was China. Muslim religion, in turn, encouraged the search of new information and skills everywhere, as it is reflected in a well-known hadith: 'Seek knowledge even as far as China'.

The artistic search of Iranians led them to the Chinese items. They transformed them and created the distinctive art types of ceramic items, revising the Far Eastern tradition in order to create something authentic, complying with the Iranian discourse.

It is necessary to clarify what is meant by the compliance with the Iranian discourse. There is a process of perception of certain forms and style as a whole.

The perceptive side in the context of this article is Iranian culture with its artistic perception, which, in turn, is inherently a synthesis of the artistic aspirations of that era. Creators perceived new forms processing that information according to the modus of their vision. This procedure turned out possible by the recognition of the common elements. The process of discerning and infusion of the new forms therefore is a kind of operation to find a common denominator. The modus of vision of the perceptive side, in turn, identifies the selection of the elements.

It is therefore not quite a question of the influence. Shukurov, who is a historian and a theorist of Iranian and Eastern Mediterranean region's art clarifies that referring to the influence of certain forms and styles, the perceptive side with a kind of adjustment mechanism towards the other is often forgotten¹⁰.

With these points in mind, it is appropriate to begin consideration of result of comprehension of the Far Eastern art ideas. This result can be seen, for instance, in the case of the items inspired by Chinese 'three-colour' ware. The aforementioned Chinese earthenware, also known as 'sancai' ware, relates to the Tang dynasty (618-906).

The external resemblance was achieved by different materials. Chinese wares consisted of kaolin that was not available in Islamic world where it was replaced by different clay composition. The

colour of this material ranged after firing from buff to red, whereas Chinese kaolin remained white even after firing.

The body was covered by creamy white engobe. The engobe was applied before firing on the surface of item and hid the colour and porous structure of the body's material. The second phase was a decorative coating: yellow, green, to a lesser extent, purplish brown were applied by the little spots and stripes. Finally, the glaze was applied on the item.

The scattering of green particles does not allow an immediate detection of a prominent technological characteristic of lead glaze which is used for aesthetic purposes by craftsmen. The essence of this characteristic lies in the compositions of the paints. In contrast with the yellow and black paints, the green one has a copper-based composition, which runs along with lead glaze when firing.

Transforming the Far Eastern ideas the artists from Nishapur combined the aforementioned coloristic decisions of Chinese items with the sgraffito designs, which were scratched over the engobe. The lines of sgraffito in this case turned black when the green glaze was applied¹¹, which was the distinctive feature of this type of ceramic of Nishapur.

These items, therefore, represent the manifestation of *Kunstwollen*. The Iranian artists possessed the necessary impetus to create. It was the main force, thanks to which they were in pursuit of ideas, not satisfying with the principles had already found.

Iranian artists were also inspired by the snow-white items, which were imported mainly from the Hebei and Henan provinces¹². The snow-white background of these wares became a basis for creation of a new ceramic's type: a group of items with inscriptions on a creamy white ceramic surface covered with a transparent lead glaze.

SOURCE OF INSPIRATION: ARABIC LANGUAGE

Another source was the Arab world. Arabs, together with the graphic style of thinking, brought the order to the Iranian artistic tastes that had been formed before the birth of muslim religion. Iranian artistic thinking was formed through a religious mode of vision with its ritual side, different from Arabic.

Iranian *Kunstwollen* can also be traced through the example of the ceramic items with Kufic Arabic inscriptions on a creamy white opaque ceramic surface. This group of ceramic items is significant in the context of this article not because of its technological characteristics, that were described by Wilkinson¹³, but due to its artistic decision.

The dishes and bowls are embellished with Arabic inscriptions in black or red. An educated population was essentially bilingual, scholars and literary figures worked in Arabic. The texts of the inscriptions consist of proverbs and a variety of maxims that do not refer to religion, but as the embodiment of wisdom.

Nevertheless the most essential phenomenon in this type of earthenware is the transformation of these inscriptions into ornament. The aesthetics of Arabic calligraphy seamlessly began to grow on Iranian ground, being modified over time beyond recognition.

This is also due to the nature of the Arabic script, aspiring to ornamentation. The perception and comprehension of the ornament is the consequence of identification of the motifs, themes and also the ways of its binding by the human eye¹⁴. The rules of binding of the letters is the second phase after learning of the Arabic alphabet for those who wish to learn the Arabic language.

Returning to the transformation of the inscriptions into the ornament, it is important to note, that it is the same process of adaptation of the environment complying with the Iranian discourse.

By the example of this group of earthenware the changes in the inscriptions transpired gradually. At times, in the place of the restrained, refined, unadorned Kufic inscriptions came the transformation of letters or parts into the zoological elements, such as waterfowls with the long beaks and necks. Thus the first animalistic inscriptions in the art of Islam were born, highlighting the secular character of this production. An absolute illegibility frequently comes along with it. Obviously, that is not a result of negligence, but the artistic decision.

SOURCE OF INSPIRATION: LEGENDARY PAST OF IRANIANS

Not only the intervening Arab ideas were transformed. The creative vision of the Iranian artists was able to transform the former images of the Iranian ethnos.

A group of items depicting festive scenes, feasting, hunting, serves as an example to this. The representations of festive scenes often with cupbears, musicians reflect an atmosphere of abundance. The hunting images also follow the themes of a horseman or a king. These subjects and images go back to the themes of the Sasanian silver dishes. In contrast to the Sasanian items, there is no dramatic component in these scenes. Furthermore, this type of style, so-called 'kaleidoscope' is also the reflection of the cosmopolitan atmosphere prevailing in the cities of the eastern Islamic lands during the Abbasid period.

According to Heidegger¹⁵, the tradition brings to the light the covert values of what was once, even if that light is the vacillating one of the day break. In the case of this group of ceramic such tradition is the legendary past of Iranians, as a source of inspiration for Iranian artists.

CONCLUSION

During the examination of some ceramics types, certain principles of the internal organization of the artistic process that Nishapur's artists followed were expressed. It is also possible to describe the points of contemplation of reality, for the factors that apply to the processing of external impressions also apply to the development of works of art according to Alois Riegl.

Iranian artists were constantly in pursuit of new ideas, not content with the style once found. Through their perception of the outside world they created the new forms, artistic decisions, principles of style.

One of the important consequences of their search of artistic ideas and its subsequent embodiment was the technological development in the field of ceramics production. This is another confirmation that the creation of the piece of art is not only the consequence of technology and current materials, as Semper claimed¹⁶. In contrast, the approach of Riegl, based on the concept of *Kunstwollen*, which transcend the technology or the utility is confirmed by the example of Iranian ceramics.

In the case of ceramics types discussed in the preceding sections, it is important to highlight one more time the force of *Kunstwollen* search and the artistic will for artists in Nishapur. Hardly had the Iranian artists appealed to foreign form when they transformed it according to the *modus* of their viewing. The same process occurs with other forms from which the Nishapur's artists were seeking for inspiration.

The ceramics of the eastern lands of the IX-XII century Caliphate is also an outstanding example of a combination of the Arab and Iranian worlds' traditions. The merging of the pre-Islamic Iranian traditions with the graphic mindset of the Arabs stimulated the creation of the various types of designs and aesthetic effects of ceramic's production.

There is therefore some evidence to suggest that Iranian art in the first centuries of Islam had its own course of development based on the flexibility of culture and awareness of its own identity.

In this conjunction Grabar's general conclusion on the regional nature of the Iranian art before Mongol conquest not being "part of the newly formed Islamic art"¹⁷ is confirmed.

The study also revealed that the process of affirming of the Iranian identity through Kunstwollen can be traced in Nishapur's ceramics.

Bibliographic references

- ¹ WILKINSON Ch.K. *Nishapur. Pottery of the early Islamic period*. The Metropolitan Museum of Art, New York, 1973.
- ² RANTE R. COLLINET A. *Nishapur revisited. Stratigraphy and Ceramic of Qohandez*. Oxford and Oakville, 2013.
- ³ RIEGL A. *Stilfragen. Geschichte der Ornamentik*. Verlag von Georg Siemens, Berlin, 1893.
- ⁴ RIEGL A. *Spätromische Kunstindustrie*. Wissenschaftliche Buchgesellschaft, Darmstadt, 1973.
- ⁵ BARTHOLD W. *Raboty po istoricheskoy geografii i istorii Irana* [An Historical Geography of Iran]. Vostochnaya literatura, Moscow, 2002;
- BOSWORTH C.E. "NISHAPUR i. Historical Geography and History to the Beginning of the 20th Century," *Encyclopædia Iranica*, online edition, 2018, available online at <http://www.iranicaonline.org/articles/nishapur-i>
- ⁶ RANTE R. COLLINET A. *Nishapur revisited. Stratigraphy and Ceramic of Qohandez*. Oxford and Oakville, 2013. P. 204.
- ⁷ SOUSTIEL J. *La céramique islamique*. Suisse, 1985. P.54.
- ⁸ WILKINSON Ch.K. *Nishapur. Pottery of the early Islamic period*. The Metropolitan Museum of Art, New York, 1973. P.xlii.
- ⁹ ETTINGHAUSEN R. GRABAR O. *The Art and Architecture of Islam 650-1250*. The Pelican History of Art, 1987. P.229-230
- ¹⁰ SHUKUROV Sh. *Khorasan. Terrotoriya iskusstva* [Khorasan. The Art Territory] Progress-traditsia, Moscow, 2016. P. 106.
- ¹¹ WILKINSON Ch.K. *Nishapur. Pottery of the early Islamic period*. The Metropolitan Museum of Art, New York, 1973. p.56.
- ¹² KADOI Y. *Islamic Chinoiserie. The art of Mongol Iran*. Edinburgh University Press, 2009. P. 39-73.
- ¹³ WILKINSON Ch.K. *Nishapur. Pottery of the early Islamic period*. The Metropolitan Museum of Art, New York, 1973. pp.90-127; 128-157.
- ¹⁴ GRABAR O. *Mediation of the Ornament*. Princeton University Press, 1992.
- ¹⁵ HEIDEGGER M. *Raboty i razmishleniya raznyh let* [Works and reflections of different years]. Gnozis, Moscow, 1993. P.268. (in Russ).
- ¹⁶ RIEGL A. *Spätromische Kunstindustrie*. Wissenschaftliche Buchgesellschaft, Darmstadt, 1973. P.8.
- ¹⁷ GRABAR O. *The visual arts*. R. N. FRYE, *The Cambridge History of Iran*. Frye R.N. (5th ed., Vol. 4, P. 331). Cambridge University Press, 2007.

Tiles in the Museum of Civil Engineering

Alcnia Zita Sampaio

*Dep. Civil Engineering, IST, University of Lisbon, Lisbon, Portugal,
zita.sampaio@tecnico.ulisboa.pt*

SUMMARY: The Museum of Civil Engineering of Instituto Superior Tcnico (IST) contains a significant collection of elements related to the different areas involved in the Construction sector. Concerning the Architecture topic the Museum contains the re-creation of the work room of the architect Alvaro Machado, first professor of architecture of the IST, and a collection of drawings of his projects. The architect was the author of a vast work, and following the tendency of using tiles as decorative details in buildings' facades, he applied tiles in his projects. Several pencil drawings, ink and watercolor on paper of architectural projects are shown in the text, as well as pictures of tiles applied in buildings.

KEY-WORDS: Tiles, heritage, atelier of architect, projects, drawings

INTRODUCTION

A Museum, when inserted in a technical university, is a privileged place for the preservation of the historical memory concerning the construction techniques evolution along ages, including the progress of the architectural tendencies used in urban buildings. The construction industry has been evolving in teaching methods and applied technologies. The Museum presents a reminder of how the technology advanced to the current methodologies of work.

The Museum of Civil Engineering contains a great set of elements offered by teachers and entities which is in exhibition, in a proper room, inserted within the school space. Elements such as: a model of the *Pombaline* cage, illustrating the constructive technique anti-seismic applied after the earthquake of 1755; a segment of an earth panel, identifying a wall constructive technique previous to the reinforced concrete; a massive ceramic brick of *Ivry-Paris* type, made in cast by the Lusitania factory [1]. These elements are examples that are preserved and kept in adequate conditions in technologic Museum space, contributing to the dissemination of the technical heritage and to the memory of Construction history.

Concerning the Architecture topic the Museum contains the re-creation of the work room of the architect Alvaro Machado and a collection of drawings of their projects. The drawings are used to show how antique tendencies in architecture were and to support old methodologies of representing projects, as they are confronted to current definitions of Technical Drawings. In the context of the congress the focus of this report is the atelier of the architect Alvaro Machado and their projects.

THE MUSEUM

The Museum of Civil Engineering was inaugurated on December 20th, 1993, on the ground floor of Civil Engineering Pavilion of the Instituto Superior Tcnico (IST). Until the creation of the Museum, educational materials, currently not in use, were found in professor's offices,

laboratories and classrooms. Other elements of interest related to the areas of knowledge developed in the Department, have been donated to the Museum.

The Museum contains a vast collection of elements related to the Construction activity [2]. The didactic heritage, gathered for the Museum, was located in offices, laboratories and classrooms, maintained by teachers and staff of the Department. Additionally, other pieces of scientific interest and related to the areas of knowledge developed in the Department, have been offered by teachers, alumni and construction enterprises. All objects were restored and kept, scheduled and organized properly. Each piece is identified and characterized, namely, the place of origin, the identification of the donor and the state of conservation when received.

The inventory classification process follows a thematic organization related to the different engineering domains: Transport, Bridges, Topography, Architecture, Materials, Construction techniques, Drawings, Hydraulic and Soil mechanics. For all the pieces in exhibition in the room, a descriptive text of its features, functionality, period of use and the number of inventory was drawn. Regularly, the Museu room presents exhibitions of pedagogical character and is regularly changed in order to allow the exhibition of all its reserves (Figure 1).



Figure 1: Out-side and in-side views of the Museum.

As the school is a space of several international events, namely, conferences and technical meetings, the Museum became an interesting place for national and international visitors. Supporting this interest, the current direction promoted the identification of all elements and the linked text, in Portuguese and English. So the Museum provides to:

- Students, an organized documentation of interest for research works conducted by graduate or PhD students;
- Teachers, the complementarity of disciplines providing support to the programmatic curriculum, with the description of old equipment;
- Visitors, an important collection of books, photographs, drawings, models and equipment related to the construction industry.

ATELIER OF THE ARCHITECT ÁLVARO MACHADO

Architect Álvaro Machado (1874 - 1944) was the first teacher of Architecture at the IST of the Technical University of Lisbon, from 1911 to 1936. The room recreates his atelier, originally installed in his house, in Lisbon, and the contents were offered to IST, by his daughters, in 2000. The work place was meticulously built by Machado, since 1910, over years of use. All the furniture was designed by him, and it is composed of desk, tripod support, bookcase and banks. The organization of the walls was the target of a careful record left by him, facilitating the reconstitution presented in a specific room built inside the Museum space (Figure 2).

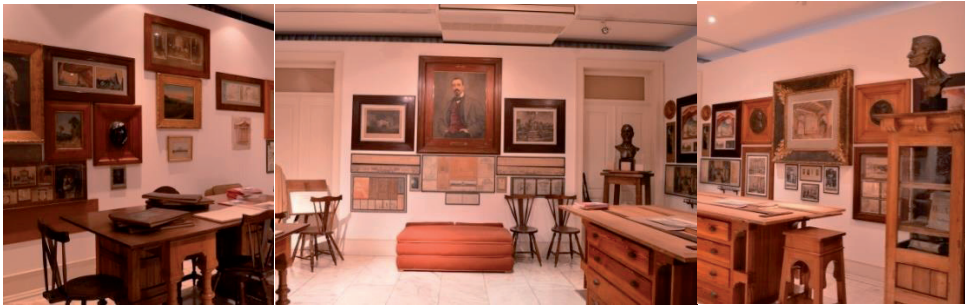


Figure 2: The re-creation of the work room of the architect Álvaro Machado.

The selected elements includes: paintings and drawings of their architectural projects; drawings and paintings made by colleagues and friends, namely Raul Lino, Ezequiel Pereira and Miguel Queriol; draft scenarios designed by his father; portraits of masters like José Luis Monteiro and from himself painted by Constantino Fernandes and Ferreira da Costa. Figure 3 presents pencil drawings, ink and watercolor on paper of architectural projects. Some of his architectural designs are placed in the archive of the IST [3].



Figure 3: Pencil drawings, ink and watercolor on paper of architectural projects.

According to the publication co-hosted by Caldas [4], on the occasion of the atelier opening, the authors refer to his vast work. Some of the design works, organized in the framework of competitions, were also donated, complementing the furniture and belongings. In the same booklet, António Ressano Lamas says that *the quality of the drawings and the aesthetic and historic interest of the environment preserved were notable and could not immediately be dispersed* and so the IST kept *their documents and projects to be consulted and they are open to researchers to study his work.*

TECHNICAL DRAWING

Alfredo Bensaude (1856-1941), the first director of Instituto Superior Técnico (IST), of the University of Lisbon, creates the first national technical school of engineering based in the international standards at the time, and contributed to introduce the Technical Drawing as an essential issue and training for the future engineers [5]. The interest in empowering the country with a good technical training of all trust contributes to develop the latent skills of its citizens, make a more systematized and economic industrial production and, especially, to make Portugal less dependent from abroad. The development of the industry is the natural and indispensable complement of a protectionist national policy. In such sense, it is important, in an academic level, to develop technological education as possible.

The various reforms over the years, in public engineering schools, have pointed to recognize a faculty with theoretical and practical capabilities. In a technological school, as the IST, theory must be inseparable from practice. Not just the student acquiring successively during some years the knowledge of different disciplines of the course, it is necessary that they also get a homogeneous set of theory and knowledge of how to apply it. The creator of the first engineering school in Portugal in 1911, Alfredo Bensaude, advocated the importance of bringing theory into practice. The drawing is used as a way to develop components with the accuracy needed for students' workshop, committing the student into the manual manufacture [6].

Alfredo Bensaude reported in his memories, the main guidelines that are still the current support of pedagogical methods of technical and scientific nature, implemented in the teaching of engineering in Portugal [6]. The objective proposed by Bensaude was to *provide the nation with engineers not only with knowledge based in theory, but also with the necessary practical skills, that could contribute to the economic progress of the country*. So students should design wooden models, connect metallic elements and realize chemical experiments in workshops located in the old IST building. In Bensaude memories he refers that *today [1922] the workshops are attended regularly by students, wearing worker suits and working alongside with professors and professional craftsmen*. Figure 4 presents pictures illustrating several workshops, made available by the archive department of the IST [7].



Figure 4: Views of the workshops located in the old IST building.

In the first curricular reform, Drawing became the 51st discipline of the general course of the Institute. It was offered to all the engineering students, and has duration of 2 academic years: in the first year drawing is rigorous and executed with pencil, ink and watercolor; in the second curricular year freehand sketching and execution of chalk drawings on cardboard were included. In 1918, the courses were restructured and the discipline was renamed Technical Drawing, corresponding to the 47th chair of the common core of all courses, with a curricular program consisting of 3 parts: Construction drawing; Machinery drawing; Architectural drawing. The Technical drawing and Architectural drawing disciplines were taught by Álvaro Machado (Figure 5).

In 1911, when the creation of IST, Machado is one of the seven teachers, coming from the old school, which is invited by Alfredo Bensaude, as a senior lecturer of the new school, having taught the discipline of Architectural Drawing, until 1934.

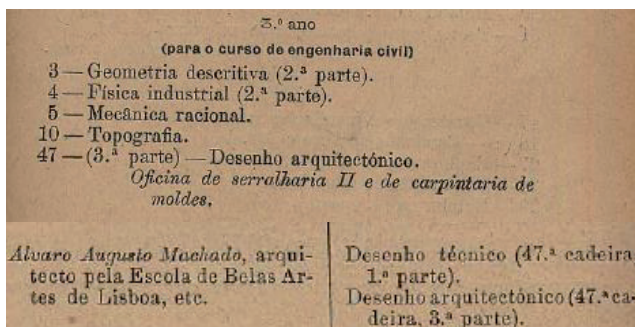


Figure 5: Architectural drawing discipline [6].

Distinct free hand methodologies, didactic procedures of teaching technical drawing to engineering students, and the establishment of rules have been evolved over the years and centuries in the history of engineering. Bensaude contributed to establish a strategy for the implementation of the Technical Drawing as a science in an engineering school, that is patent in the vast collection of antique drawings, belonging to the Museum, preserving the memory of the evolution in the drawing discipline taught in the school. The Museum has a huge collection of drawings executed by students, dating back to the formation of the IST until after World War II (Figure 6).

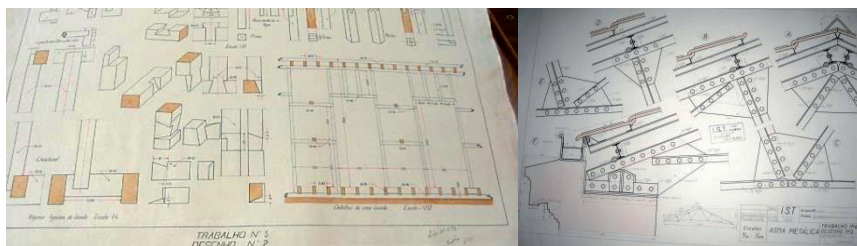


Figure 6: Drawings of wooden and metallic structures.

Diverse type of tools used to trace drawings is also in exhibition in the Museum. The vast set of elements clarify, students and visitors, about the old process of drawing, based in the use of pencils, ink or watercolour, and how to use scale rulers, squares and "T" rulers (Figure 7).



Figure 7: Antique drawing devices.

ARCHITECTURAL PROJECTS

Álvaro Augusto Machado proved early to be a young architect with great imagination, but he expressed it in a realistic mode. He defined his work with a great intellectual and logic discipline that applies in the design of new architectural resolutions. He was the author of several projects of single-family buildings in the zone of Lisbon:

- The Valmor prize was not awarded in 1918, possibly due to political, economic and social instability that struck the country, but, in 1919 the Valmor prize was awarded to a single-family, located in Av. Duque de Loulé, Lisboa, dwelling owned by Alfredo May de Oliveira with an Alvaro Machado project (Figure 8). This house had three floors of sober lines and presented a structure essentially urban. It was demolished in 1961 and gave way to a building with seven floors [8];
- The building of the Museum Bordalo Pinheiro was built in 1913 by the poet Santa Cruz, friend of Bordalo Pinheiro, with the architectural project of Álvaro Machado. He was awarded an honorable mention of Valmor prize of 1914. The building contains a biographical and monographic documentation dedicated to the life and work of Rafael Bordalo Pinheiro (1846-1905), an important artist and politician of the 19th century [9]. The spoils of the Museum comprise the most complete collection of ceramic of Bordalo, representing his typical over-naturalism, as well as an extensive exhibition of painting, drawings, documents and publications (Figure 8).



Figure 8: Two awarded Machado's projects.

- The building of the current Academic College, located at the Republic Avenue, was designed in 1904. In 1906 it was purchased by Madame Anne Roussel, founder of the school with her name, destined to be an establishment of education of female children. From 1920 worked on building the English College, the School Minerva and currently the Academic College [10].
- The building of the National Society of Fine Arts (SNBA), located at Rua Barata Salgueiro, in Lisbon, was designed by Machado, having been inaugurated in 1913 by the President of the Republic Manuel de Arriaga on the occasion of the 10th art exhibition [11]. Their projects follow the current Romanesque observed in volumetric values of Romanesque and the affirmation of the decorative component marked by the use of tiles.

The architect applied tiles on façades of urban buildings. Figure 8 illustrates the application of some detail made in ceramic applied on façades of the Museum building. Figure 9 represents a picture of the SNBA building and a drawing of the architectural project. Figure 10 presents images with details of the tiles applied on façades of the Academic College. Figure 11 presents pencil drawings, ink and watercolor on paper of the architectural project of the House of Health Portugal-Brazil in Lisbon, showing tiles applied in facades, and Figure 12 includes a drawing of the project designed for Hotel of Health, in Estoril.



Figure 9: The SNBA building: picture, publication and drawings.



Figure 10: Tiles applied in the facade of the Academic College.



Figure 11: Drawings and detail of the House of Health Portugal-Brazil project [3].

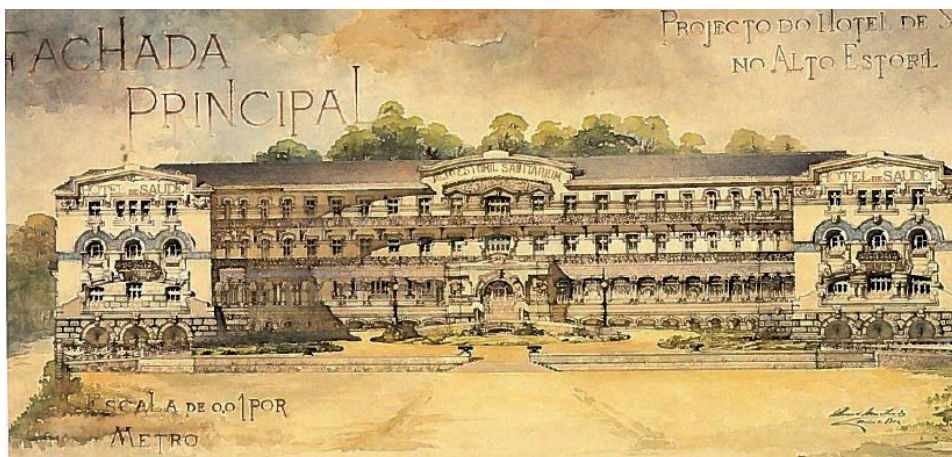


Figure 12: The project drawing designed for Health building Hotel in Estoril [3].

CONCLUSIONS

The Civil Engineering Museum contains the re-creation of the atelier of the architect Álvaro Machado, professor of architectural drawing and technical drawing and designer planning of relevant buildings. The spoil of the Museum encompasses several drawings prepared by his students in the disciplines of Architecture and Technical Drawing and the material used to represent those drawings.

The architectural drawings outlined by the architect are part of the estate given to IST. Several buildings designed by the architect present tiles on facades. The drawings show also the application of tiles on facades, and how each ceramic element is represented in detail using watercolor. The tiled designs applied and the buildings are presented in the text. The quality and aesthetic of the drawings are evident supporting the great interest of IST to preserve these notable graphic works made by Machado and so it could not be dispersed.

The Museum serves as a memory of architectural work of Alvaro Machado, represented in various drawings, and contributes to the dissemination of his work revealed in several buildings in the zone of Lisbon.

Bibliographic references

- ¹ *Museum of Civil Engineering*, <http://museudec.tecnico.ulisboa.pt/>
- ² SAMPAIO, A. Zita - *Spoil of the Museum of Civil Engineering*, Museum of Civil Engineering, IST, Lisbon, 2016
- ³ NARQ - Núcleo de Arquivo, IST, Lisbon, <https://narq.tecnico.ulisboa.pt/>
- ⁴ CALDAS, João, PERA, Teresa - *Álvaro Machado, first professor of Architecture at the IST - exhibition of the donated estate*. Museum of Civil Engineering, IST, Lisbon, 2002.
- ⁵ SILVA, Palmira, PEREIRA, Manuel, SOARES, Filipa - *The genesis of the Instituto Superior Técnico – Alfredo Bensaude*. Althum.com, Lisbon, 2011. <http://narq.tecnico.ulisboa.pt/extensao-cultural-e-educativa/exposicoes-fisicas-eou-virtuais/a-genese-do-tecnico-alfredo-bensaude/>
- ⁶ BENSAUDE, Alfredo - *Historical-pedagogical notes about the Instituto Superior Técnico*, Lisbon, 1922, <http://alfredobensaude.ist.utl.pt/nucleos/nucleo/id/3/paginaid/24>
- ⁷ BOBONE, Augusto - *Center for photography*, Lisbon Municipal Archives, 18920. <http://alfredobensaude.ist.utl.pt/nucleos/nucleo/id/3/paginaid/76>

⁸ *Valmor Prizes*, Municipal Chamber of Lisbon, <http://www.cm-lisboa.pt/viver/urbanismo/premios/premio-valmor-e-municipal-de-arquitetura>.

⁹ *Museum Bordalo Pinheiro*, <http://museubordalopinheiro.cm-lisboa.pt/>

¹⁰ *Academic College*, <http://lisboadeantigamente.blogspot.com/2015/09/colégio-academico-e-patisserie.html>

¹¹ *National Society of Fine Arts - SNBA*, <http://www.snba.pt/>

The use of “Tijomel” tiles in Portuguese modern architecture

Catarina F. M. Geraldès

Departamento de Conservação e Restauro, Faculdade de Ciências e Tecnologia, Universidade NOVA de Lisboa, Caparica, Portugal; Laboratório Nacional de Engenharia Civil (LNEC), Lisboa, Portugal; cgeraldes@lnec.pt

João Manuel Mimoso

Laboratório Nacional de Engenharia Civil (LNEC), Lisboa, Portugal, jmimoso@lnec.pt

Alexandre N. Pais

Museu Nacional do Azulejo, Lisboa, Portugal, apais@mnazulejo.dgpc.pt

SUMMARY: Several books present and discuss the use of tiles (azulejos) in Portuguese modern architecture. However, these tend to ignore the use of other glazed ceramics of uncertain classification in the same context. Through the process of identification of modern azulejos in Portuguese cities, a new type of glazed ceramic coating has been found which may arguably be classified as azulejos. These are mosaics with a module of 20 x 40 mm whose units are flat glazed ceramics. The only difference from what we usually understand as azulejos result from the facial dimensions (ca. 18 x 38 mm) of those tessellae. They were manufactured at Ourém, Portugal, by a company named Tijomel from 1960 to 1980 and are a unique product that was widely used at the street level as well as in certain details of modern buildings, such as columns or entrance doors. Tijomel mosaics were often used with great creativity and quite striking results. The authors believe that this type of coating is worth considering as part of the modern heritage in Portuguese architecture and decoration. Therefore, the aim of this paper is to present and discuss for the first time the use of the Tijomel mosaics, revealing several examples of use.

SUMÁRIO: Vários livros apresentam e discutem o uso de azulejos na arquitetura moderna portuguesa. No entanto, estes tendem a ignorar o uso de outras cerâmicas vidradas de classificação incerta, no mesmo contexto. Através do processo de identificação dos azulejos modernos nas cidades portuguesas, foi encontrado um novo tipo de revestimento cerâmico vidrado, que pode ser classificado como azulejo. Trata-se de mosaicos com um módulo de 20 x 40 mm com unidades cerâmicas de vidro plano. A única diferença em relação ao conceito comum de “azulejo” resulta das dimensões (cerca de 18 x 38 mm) dessas tesselas. Foram produzidos em Ourém, Portugal, por uma empresa chamada Tijomel, entre os anos 1960 a 1980 e são um produto único, amplamente utilizado ao nível da rua, bem como em certos detalhes de edifícios modernos, como colunas ou portas de entrada. Os azulejos Tijomel eram frequentemente utilizados com grande criatividade criando resultados impressionantes. Os autores acreditam que este tipo de revestimento merece ser considerado como parte do património moderno na arquitetura e decoração portuguesa. Neste sentido, o objetivo deste artigo é apresentar e discutir pela primeira vez o uso dos mosaicos de Tijomel, mostrando uma selecção de casos.

KEY-WORDS: Azulejos, Tijomel mosaics, Modern architecture, Portugal

INTRODUCTION

Several books [1-8] present and discuss the use of *azulejos* in Portuguese modern architecture. However, these tend to ignore the use of other glazed ceramics of uncertain classification in the same context. The glazed ceramic objects for architectural linings establish a connection with the surface where they are integrated, providing an aesthetic experience. The discussion of what is considered *azulejo* is difficult since it should not indeed be a matter of strict dimensional limits.

The *azulejo* is a traditional art in Portugal, much more than an object, thus encompassing a wealth of shapes and dimensions. In this sense, the authors consider important to mention a type of glazed ceramic coating that came recently to their attention whose dimensions are different from the common Portuguese *azulejo* (ca. 140 x 140 mm). These are glazed ceramic units with facial dimensions 18 x 38 mm produced in many colours and abstract patterns (figure 1). These coatings were widely used in Portuguese modern architecture, however, apart from a slight reference to these mosaics found in the website of *Cerâmica modernista em Portugal* [9], there are no studies regarding these “azulejos” nor known references to them in the published bibliography. These unique products, manufactured from 1960 to 1980 by the extinct Portuguese factory Tijomel, in Caxarias, Ourém, are considered by the authors as *azulejos* and as such will be analysed in this paper [10].



Figure 1: Examples of Tijomel mosaics. Left: *Rua dos Olivais, Viseu*; right: *Rua dos Palomes, Torres Vedras* (integrating two different patterns)

The Tijomel mosaics are often found at street level, as in shops or in the entrance of buildings or lining pillars as a decorative detailing, complementing modern buildings and sometimes in lieu of *azulejos*, while aiming at the same decorative purposes. In our research, several Portuguese cities such as Lisbon, Porto, Torres Vedras and others were visited allowing the identification of many interesting, previously unknown examples, which denote a clear artistic intention in their integration since the colours, patterns and areas lined, create a diverse and often striking impression.

All cases included in the present paper are considered from the point of view of a street walker, therefore excluding the more utilitarian use in interiors. Due to the high number of cases found, the calling to the attention of their use in modern architecture in Portugal is of particular

interest. The importance of bringing to light their integration is related with the will to create potential interest for their preservation as cultural heritage worthy of care.

TIJOMEL FACTORY

Slightly mentioned in the literature, the Tijomel factory was, at a time, considered the most modern ceramic factory in the Iberian Peninsula [11]. Created and managed by Júlio Redol, it was located in Caxarias, Ourém (Central Portugal, not far from the city of Leiria) and would suffer from relational and economic instability after the 1974 revolution, leading subsequently to its closure. Through research, it was possible to find publications [11-15] related to the exhibition held at the *Museu Municipal de Ourém*: "Ao Redol da Tijomel" following the study of three young designers - Mélanie Rodrigues, Luís Freire and Rúben Pereira, regarding the factory and the legacy left by its founder Júlio Redol.

Júlio Redol Nunes was born in Tomar in 1915. Initially, he worked in the Prista ceramics factory where his dynamism and entrepreneurial spirit have revolutionized the manufacturing methods. Later, Redol decided to create his own factory in Caxarias and the company was founded in 1941 under the name "Materiais para Edificação Lda". Only in 1961 did it become "Tijomel". Located next to the railway line it had a wealth of raw materials available in the region, such as clays and sawmill waste, creating the ideal conditions for the industry. It contained two sections, the "pavimel" and "decormel" and scoped the entire production of ceramics, from the raw material to the final product, as well as its commercialization [11, 13]

In its grounds, there was a canteen, medical service, school, library, constituting a model of social assistance unusual for the time. It would have had approximately 300 workers and some modern artists, such as Júlio Resende who developed projects there [11, 13]. One of his work is the panel "O Café" where he used glazed bricks, present in *Confeitaria Sical* in Porto [16]. Figure 2 shows a catalogue from the section "decormel" and the different types of Tijomel mosaics available.

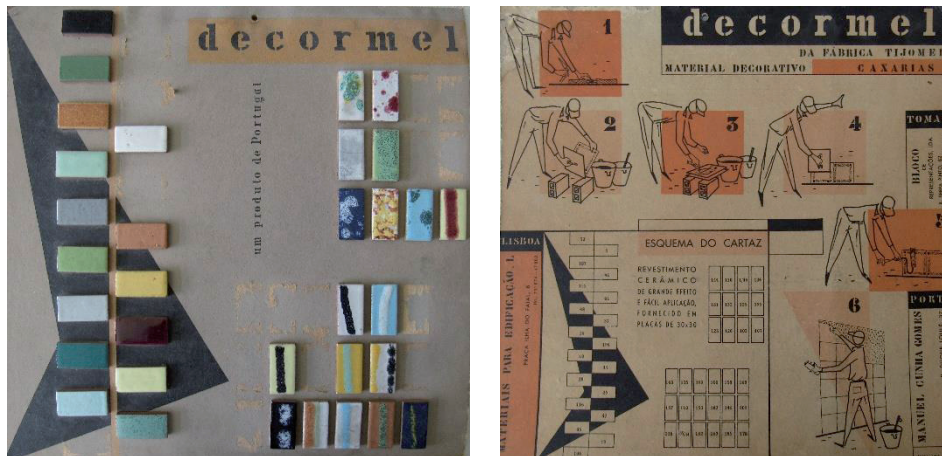


Figure 2: Catalogue from the archives of *Laboratório Nacional de Engenharia Civil* of the section "decormel" with different Tijomel mosaics available

The factory closed in the 80's and its founder Júlio Redol died shortly afterwards. The building remained abandoned thereafter [11, 12]. Figures 3 and 4 offer a glimpse of the greatness of the factory and some spaces that survived the ruin. The entrance is all lined with Tijomel mosaics

(figure 4) which is very interesting since it seems to work out like a catalogue of the products or as an invitation for those who would go to the factory and could see a showcase beforehand.



Figure 3: The factory building. *Caxarias*, 2018



Figure 4: The entrance of the factory. *Caxarias*, 2018

Figure 5 presents some Tijomel mosaics applied on the walls of the factory and the several possibilities of colours. Many of them have the same pattern that have been found in buildings of Portuguese towns screened by the authors.

The land around the factory was, however, divided and sold to several owners [13]. The study of the production of this company is particularly important given their uniqueness. Such study may also reflect on the knowledge of the materials and contribute to a more conscious future intervention of this type of coating.



Figure 5: Tijomel mosaics applied on the walls in the factory building. *Caxarias*, 2018

THE PROFUSION OF UNKNOWN CASES

As discussed by the same authors [17], understanding the relevance of modern *azulejos* in Portugal as cultural heritage and the reason of their integration in architecture is important to foster their preservation. Lining or decorative detailing at street level is particularly relevant because its decorative intention easily reaches the viewer.

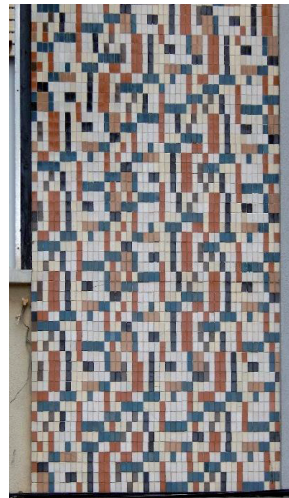
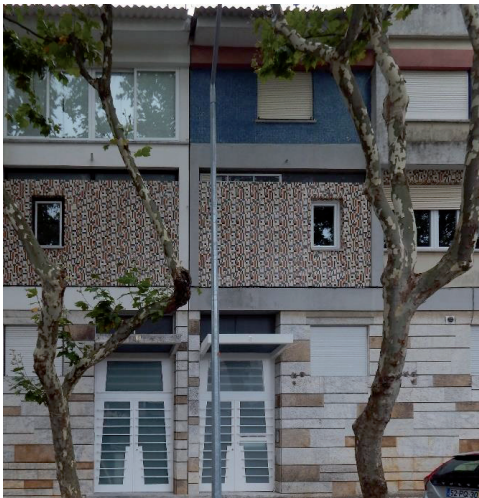


Figure 6: *Avenida do Lago N° 61*, Estoril

The modern Portuguese architects adopted a solution that has not been seen elsewhere and is routinely overlooked in Portugal. The use of Tijomel mosaics, different in dimensions or decorative value from common Portuguese *azulejos* or glass mosaics, indeed transmits a rather unique notion of modernity.

The mosaic itself is very simple, it often has a background colour (blue, white, black etc) sometimes overlaid with areas of a different colour as can be seen in the figures. The richness of the application of these *azulejos* lies in the fact that they obtain an artistic scenario with a "game" of colours (figure 6) or varying the position of the mosaics (alternating vertically and horizontally) as can be seen in figure 7 (right), creating interesting patterns in façade areas that might otherwise look plain.



Figure 7: Some (fortunately rare) examples of decayed Tijomel mosaics

The conservation of this type of linings should stem from an appreciation of their unique aesthetics. Some cases already present degradation (figure 7), pointing to the need for preservation actions of this heritage.

Several cases (78), so far never seen mentioned, of the application of Tijomel mosaics have been found in Portugal. These were identified in nine different localities: Porto, Viseu, Ourém, Torres Vedras, Lisboa, Ericeira, Estoril, Almada and Beja. Table 1 depicts the number of applications already identified in each of those localities, of which Porto presents the higher number of examples (35). Figure 8 shows their distribution throughout Portugal.

In the following sections, selected examples of the different types of use of these coatings in modern Portuguese architecture are presented. They will (so to say) speak for their case.

Table 1: Number of cases of Tijomel *azulejos* found in each Portuguese city visited

Portuguese cities	Number of cases
North	
Porto	35
Viseu	2
Centre	
Ourém / Caxarias	6
Torres Vedras	2
Lisboa	19
Ericeira	1
Estoril	1
Almada	4
South	
Beja	8



Figure 8: Localities visited where Tijomel tiles were used

Porto and Ourém examples

The city of Porto was a surprise due to the high number of examples found (35 until now). In contrast to the *azulejos* commonly used in Portuguese architecture, usually covering whole façades, in the examples described below, there is often an intention for aesthetic appeal merely through small-scale details.

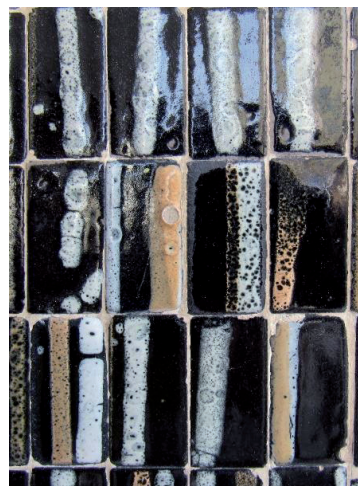
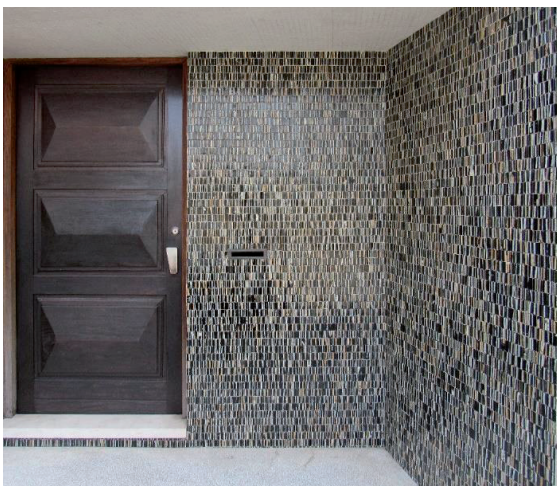


Figure 9: *Rua do Visconde de Setúbal N° 346, Porto*

Figure 9 and 10 demonstrate two different examples of Tijomel coatings integrated only in the entrance door of the buildings. The mosaics are very simple with a black background colour superimposed by odd lines in grey or fawn (figure 9) or dots of pink and white (figure 10). It is possible to see that there was a clear intention to decorate the surface appealingly, maybe for the sake of the prospective buyers and for the long-term appreciation of passers-by.

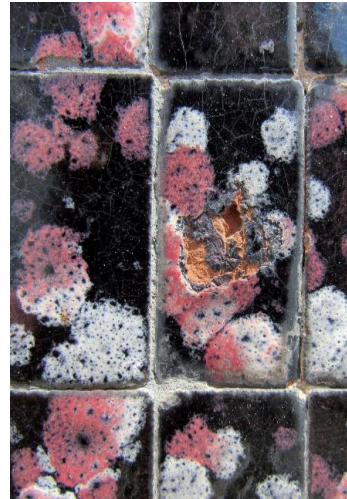


Figure 10: *Rua do Paraíso N° 104, Porto*

Figure 11 and 12 are two examples where the lining covers a larger area, creating an interest in façades that would otherwise be plain and uninteresting. In the first case, the building is in a corner of the street and its unassuming modern design contrasts with the rather sumptuous lining at street level.

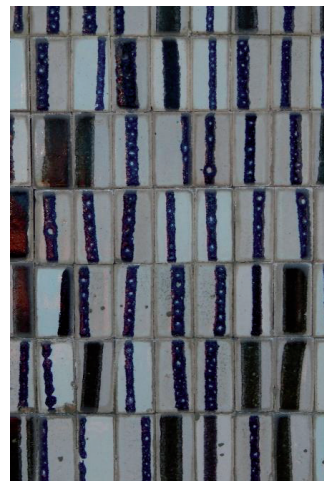


Figure 11: *Rua 5 de Outubro N° 93, Porto*

The mosaics in white glaze with a black line, create an aesthetic focus of attention that enriches the whole building. In the second (figure 12) we have a rare case of an extensive use of the Tijomel mosaics in the whole façade. Here the blue of *azulejos* only framing the protruding windows in the upper part of the building, contrasting with the verandas, like a chequerboard, creating an impact on viewers.



Figure 12: *Rua da Boa Hora N° 2, esquina com a Rua de Santa Catarina - Porto*

Another example shown in figure 13 is the group of residential buildings that are far from appealing in which the different bold colours used on the side walls completely alters the perception of buildings. These three cases can be considered relevant examples since they express innovation through the use of these linings which do not cover the entire façade and yet bear an important aesthetic value and demonstrate a clear intention to decorate the surfaces appealingly.



Figure 13: Three buildings with the “azulejos” Tijomel in Porto. *Rua do Seixal N° 75*

Figures 14 and 15 depict some Tijomel coatings in different colours and patterns applied in buildings of Porto and Ourém, the city of extinct Portuguese factory Tijomel.

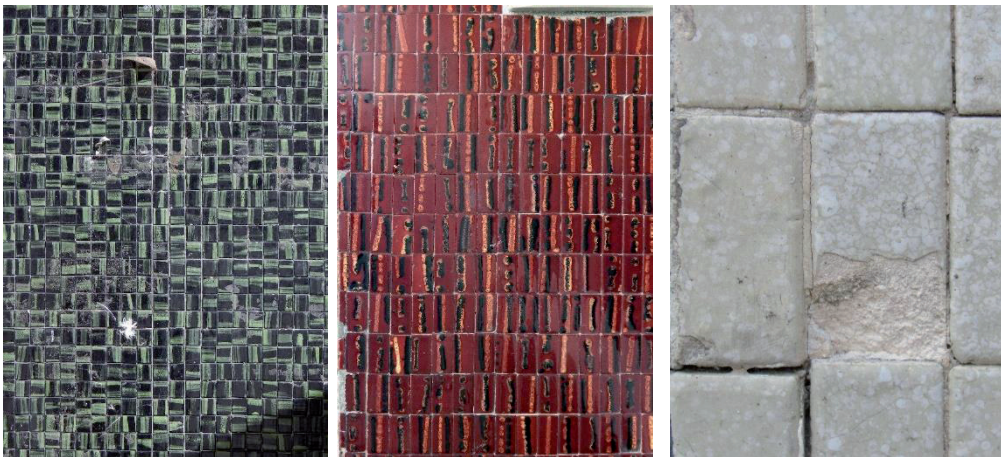


Figure 14: Detail of applied Tijomel mosaics in different buildings in Porto. Left: *Praça da Liberdade N° 121*; centre: *Rua de Fernandes Tomás N° 493*; right: *Rua Faria de Guimarães N° 357*



Figure 15: Detail of applied Tijomel mosaics in different buildings in Ourém. Left: *Av. Bombeiros Voluntários N° 55*; centre: *Praça da República N° 11*; right: *Rua Teófilo Braga N° 8*

Examples in Lisbon

Some interesting cases were found in Lisbon and satellite localities. Interestingly, amidst the many patterns and colours available, the local architects and decorators often chose identical solutions to those found in Porto. Fortunately, the vast majority is in a good condition. Figure 16 presents an example in *Avenida de Roma* in which the lining is part of a shop design and therefore only at street level, imparting, however, a sense of modernity in contrast with the rest of the building that is rather plain and devoid of decoration.



Figure 16: *Avenida de Roma N° 19*, Lisbon

Examples in other locations, such as Moscavide (in Lisbon) and at the nearby city of Amadora are demonstrated in figures 17 and 18. The curious of these coatings is that they are used, more or less sparingly, most anywhere, enriching any building where they are integrated.



Figure 17: *Rua Francisco Marques Beato N° 79, Moscavide*



Figure 18: *Rua Cândido dos Reis N° 8, Amadora*

Other types of Tijomel mosaics found in Lisbon buildings are shown in figure 19, which express once more a clear intention to communicate aesthetic appeal with the use of these coatings.

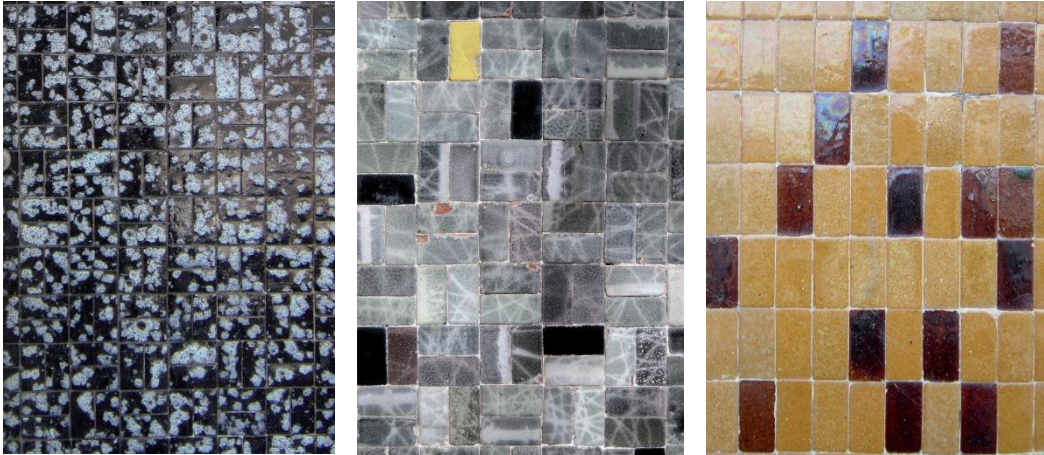


Figure 19: Detail of applied glazed ceramic Tijomel in different buildings in Lisbon. Left: *Rua da Prata N° 269*; centre: *Rua Gomes Freire N° 6*; right: *Rua Combatentes da Grande Guerra N° 43 (Moscavide)*

Interesting examples of Torres Vedras city

In the cases found in Torres Vedras, the integration is slightly different. The mosaics were applied in small areas at the upper part of the buildings, such as decorative details of the balcony seen in figures 20 and 21. Together with the architectural aesthetic of the building (figure 20) their integration creates an aesthetic impact on viewers and enriches the constructions.

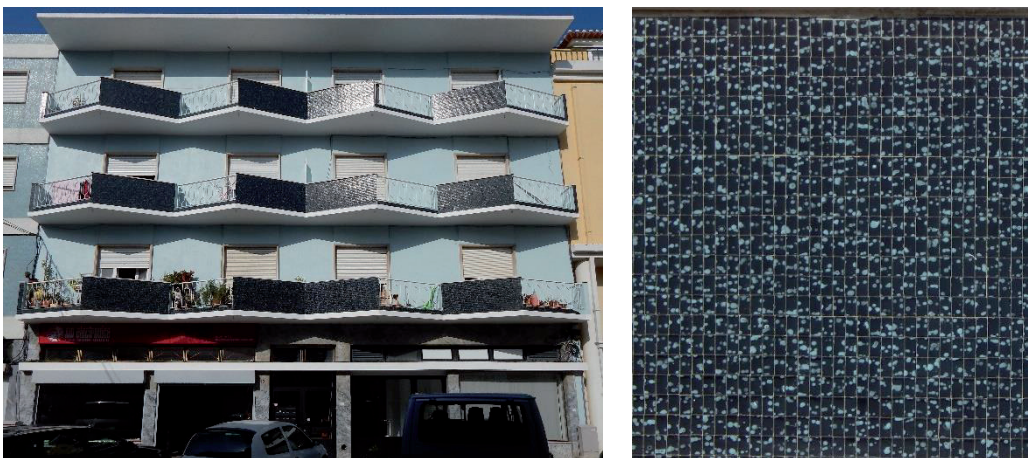


Figure 20: *Rua Dias Neiva N° 12, Torres Vedras*



Figure 21: *Rua dos Palomes N° 8, Torres Vedras*

CONCLUSION

In this paper the authors present some examples of the use of Tijomel “*azulejos*”, small pieces of glazed ceramic with 18 x 38 mm that were produced in several colours and abstract patterns, integrated on the exterior of the Portuguese modern architecture.

It was possible to identify, so far, 78 examples considered worth mentioning, most of which in Porto and Lisbon, 35 and 19 cases respectively. Most often, the applications are found at street level, such as in the decoration of shop fronts or the entrance of buildings.

Exclusively and much used in Portugal at this period, the innovation is in their peculiar aesthetics and the way they were locally integrated to the modern architecture in Portugal. The possibility of different forms of application, using the same mosaic vertically or horizontally or mixing different colours, offer many possibilities to create a sense of *Modern* and impact the observers (figure 22).

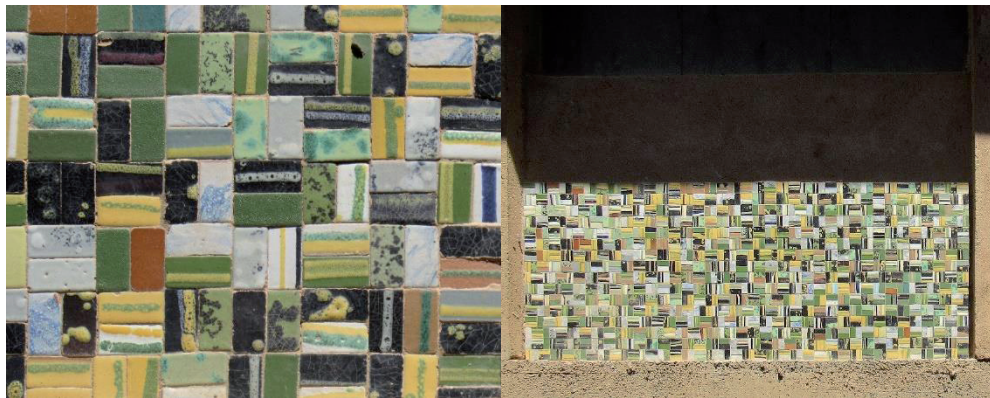


Figure 22: *Rua da Cantina, Tijomel factory, Caxarias*

In this sense, it is important to define their value as a cultural heritage in Portugal and to understand the importance of their integration in Portuguese modern architecture, as a unique regional trend. Those who studied modern *azulejos* do not seem to be aware of their existence and the knowledge about them is scarce or non-extant.

The conservation of this type of linings should stem from an appreciation of their unique aesthetics. Some cases already present degradation, pointing to the need for preservation actions of this exclusive heritage, not only for their distinctiveness but also for the way they complement the modernity of the constructions. Therefore, calling to attention their existence and relevance as a heritage asset, as well as their study and conservation are essential.

In this way, further investigations need to be carried out. The identification of more Tijomel mosaics integration in Portuguese cities, in order to gather a higher number of examples as possible and also, attempt to link to the artist / architect behind the project; understand the relation between the factory and the artists who developed their works there and, for *azulejos* preservation, the study of the factory production is particularly important. Such study will reflect on the knowledge of the characteristics of these *azulejos*, to later on be able to understand which intervention methods are the most appropriate.

Acknowledgments

The authors acknowledge the Portuguese Science Foundation (FCT) for the funding of PhD grant PD/BD/114408/2016 (Catarina Gerales) and Project **FCT-AzuRe** - Estudos no Azulejo Português para Candidatura a Património da Humanidade (PTDC/EPH-PAT/5096/2014) supporting this research.

Bibliographic references

- [1] SAPORITI, Teresa - *Azulejos de Lisboa do século XX*. No. of edition 437, Editor Porto: Afrontamento, Lisboa, 1992, ISBN 972-36-0199-0
- [2] BURLAMAQUI, Suraya - *Cerâmica Mural Portuguesa Contemporânea, Azulejos, Placas e relevos*. ISBN 972-564-270-8, Editor Quetzal, Lisboa, 1996
- [3] AMORIM, Sandra - *Azulejaria de Fachada na Póvoa de Varzim (1850-1950)*. No. of edition ISBN 972-97058-0-1, Editor Póvoa de Varzim, 1996, 2001
- [4] SAPORITI, Teresa - *Azulejos Portugueses, padrões do século XX*. No. of edition ISBN 972-97653-1-6, Editor Publilimpresores, Artes Gráficas LDA., Lisboa, 1998
- [5] CALADO, Rafael Salinas et al. - *O Revestimento Cerâmico na Arquitectura em Portugal*. No. of edition ISBN 972-8095-45-7, Editor Estar, Lda, Lisboa, 1998
- [6] HENRIQUES, Paulo et al. - *O Azulejo em Portugal no século XX*. No. of edition ISBN 972.787.009.0, Editor Inapa, Lisboa, 2000
- [7] SANTOS, Rui; PORFÍRIO, Luís; MECO, José - *Querubim Lapa Cerâmicas*. No. of edition ISBN 972-797-001-X, Editor Inapa, Lisboa, 2000
- [8] NERY, Eduardo - *Apreciação Estética do Azulejo*. No. of edition ISBN 978-972-797-150-3, Editor Inapa, Lisboa, 2007
- [9] [online] *Casa de Igrejas Caeiro | "Teatro" de Maria Keil. Cerâmica modernista em Portugal*:<http://ceramicamodernistaempportugal.blogspot.com/search?q=Tijomel> / [Accessed 20 May 2018]
- [10] [online] *O que é o Azulejo?*: <https://blogazlab.wordpress.com/2017/12/15/o-que-e-o-azulejo-3/>, 2017 [Accessed 20 May 2018]

Influence of the production technology on the morphological characteristics of azulejos

Sílvia R. M. Pereira

Laboratório Nacional de Engenharia Civil and HERCULES Laboratory- University of Evora, Portugal, spereira@lnec.pt

M^a Augusta Antunes

Laboratório Nacional de Engenharia Civil, Lisbon, Portugal, mantunes@lnec.pt

Ana Margarida Cardoso

HERCULES Laboratory- University of Evora., Evora, Portugal, amcardoso@uevora.pt

Mafalda Costa

HERCULES Laboratory- University of Evora., Evora, Portugal, mcosta@uevora.pt

José Delgado Rodrigues

Laboratório Nacional de Engenharia Civil, Lisbon, Portugal, delgado@lnec.pt

Lurdes Esteves

Museu Nacional do Azulejo, Lisbon, Portugal, mesteves@mnazulejo.dgpc.pt

José Mirão

HERCULES Laboratory-Science and Technology School, University of Evora, Evora, Portugal, jmirao@uevora.pt

António Candeias

HERCULES Laboratory- Science and Technology School, University of Evora, Evora, Portugal, candeias@uevora.pt

João M. Mimoso

Laboratório Nacional de Engenharia Civil, Lisbon, Portugal, jmimoso@lnec.pt

SUMMARY: In this article some aspects of the production technology connected with the preparation of the glaze and of the biscuit and with the firing cycle have been researched in order to better understand their effects on the morphological and chemical characteristics of the glaze and glaze-biscuit interface. Azulejo reproductions have been prepared by using raw and fired ceramic bodies glazed with either a lead-tin raw preparation or with a frit of different quartz grain sizes. The firing temperatures and the duration of the firing cycles have also been varied. The resulting cross-sections of the ceramic reproductions were analysed with SEM-EDS.

An increase in the Pb-rich K-feldspars formed at the glaze-biscuit interface is observed as the maximum temperature increases and the cooling rate slows. The use of raw glazes and single firings also promotes the growth.

The results led to a better interpretation of the technological fingerprint observed on historic glazed tiles and offer more insight into the early azulejo production technologies and on the nature of the glaze-ceramic interface.

KEY-WORDS: *majolica reproductions, azulejo, interface, production technology*

INTRODUCTION

When researching the origin of Portuguese faience azulejos, it was found that the earliest productions of the workshops of Lisbon (maybe a single workshop working since the 1550s up to at least the 1590s) were morphologically identifiable by a peculiar crystalline growth at the glaze-biscuit interface (figure 1) which usually does not occur in later productions. This growth was commonly seen in Hispano-Moresque tiles and has been ascribed to single-fired glazed ceramics. At first sight, the high quality of the painted faience glazes raises doubts on whether a single firing process was used in their production. To help clarifying these doubts, a research project was set, whose first results are here presented.

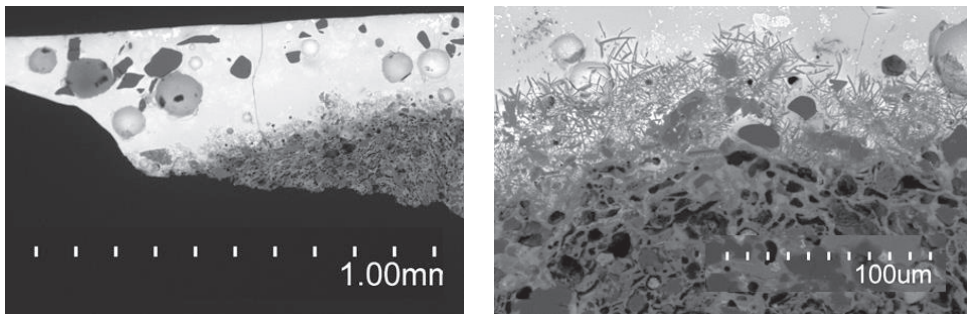


Figure 1: SEM-BSE image of a section of an azulejo from the workshop of João de Góis (Igreja da Graça- Lisboa, ca. 1565)

A better understanding of the glaze-ceramics interactions and the resulting interface is also essential to understand the azulejo as a composite material and consequently its degradation mechanisms, also contributing to develop better conservation attempts. The results of the metamorphosis supervened from the firing process also help to interpret what is seen on actual historic azulejos and to try to unravel their production technology.

During firing, the glaze fuses and interacts with the ceramic body digesting it, decomposing some constituent phases and diffusing its elements into the glaze and vice-versa [1]. When elements digested from the body diffuse into the glaze crystals are formed at the interface. For similar systems these crystals were determined to be lead-rich potassium (K) feldspars similar to sanidine with a typical formula $K_{0.4}Pb_{0.6}Al_{1.2}Si_{2.7}O_8$ [2, 3]. It is this layer of neo-formed crystals that is commonly considered and measured as the "interface layer". In 2001, and for transparent (non-tin opacified) high-lead glazes (70:30 up to 90:10 PbO:SiO₂ wt%) Molera *et al* have shown that the sanidine-type feldspar crystals form a thicker layer for higher firing temperatures and lower cooling rates [4, 5].

In this article different firing cycles (maximum firing temperature, heating/cooling rates), glaze preparation type (raw or frit glaze, silica granulometry) are researched aiming to verify their effect on the glaze-biscuit interface morphology, when tin-opacified lead glazes with a composition typical of the Portuguese azulejo productions from the last quarter of the 16th century azulejos (around 50:40 PbO:SiO₂ wt%) were used.

MATERIALS AND METHODS

Ceramic biscuits preparation

A commercial calcareous paste (SiO₂PT[®]) was used for the preparation of the biscuit. Table 1 presents its composition according to the supplier information:

Table 1: Chemical composition of the clay paste used according to the supplier in weight %.

SiO ₂ (%)	Al ₂ O ₃ (%)	CaO (%)	MgO (%)	K ₂ O (%)	Na ₂ O (%)	Fe ₂ O ₃ (%)	TiO ₂ (%)	MnO (%)	LOI (%)
47.8	15.9	12.10	1.73	2.83	0.25	4.0	0.55	0.04	14.5

For testing the effect of single, partial and double firings, glazes (raw and frit) were applied on to clay bodies that were unfired (C0), to biscuits fired at 500°C (C1), and fired at 1000°C (C2).

For firing the biscuits, a firing cycle was used with a heating rate of 100°C/h up to 500°C (C1), 50°C/h between 500 and 600°C and again at 100°C/h up to the 1000°C (C2). Both C1 and C2 biscuits were maintained for 30 min at the maximum temperature (500 and 1000 °C, respectively) and then allowed to cool down naturally.

Glazes preparation

A typical glaze composition of tiles from the late 16th century was tentatively simulated (Table 2). For its preparation, PbO from VWR chemicals, silica powder (FPS 180 and FPS 500) from Areipor, SnO₂ from Merck, K₂CO₃ from VWR chemicals, and Na₂CO₃ from Riedel de Haen, were mixed and ground together. According to the supplier, the FPS 500 quartz grain size is lower than 45 µm, with 97 % below 25 µm, while for FPS 180 the grain size is lower than 150 µm, with 45% below 53 µm and 35 % below 75 µm. Table 2 presents the resulting glaze composition expected.

The glaze mixture was both applied “raw” or after a fritting procedure to the different biscuits. For the frit, the powdered glaze mixture was fired to 1000°C and ground to less than 106 µm.

Table 2: Expected chemical composition of the glaze in weight %.

SiO ₂ (%)	PbO (%)	SnO ₂ (%)	K ₂ O (%)	Na ₂ O (%)
39	49	7	3	2

Azulejo preparation

The “raw” and frit glaze powders were suspended in water, at approximately 1:0.5 (glaze:water) and applied by brush to the surface of the different ceramic bodies (C0, C1 and C2) and let to dry overnight. The glazes were then fired according to table 3.

Table 3: Azulejos Firing Cycles (FC)

Batch	Heating rate (≈20-500°C)	Heating rate (500-600°C)	Heating rate (600-Tmax)	Tmax.	Time at Tmax (h)	Cooling rate (>500°C)	Cooling Time (h)
FC1	100°C/h	50°C/h	100°C/h	800°C	0.5	30°C/h	10
FC2	100°C/h	50°C/h	100°C/h	950°C	0.5	30°C/h	15
FC3	100°C/h	50°C/min	50°C/h	950°C	0.5	20°C/h	22.5

SEM-EDS

The resulting fired samples were cut and polished for observation of their cross-section by SEM-EDS. These observations and analyses were made at the HERCULES Laboratory in Évora using a HITACHI S3700N Scanning Electron Microscope (SEM) coupled to a BRUKER XFlash 5010 Energy Dispersive Spectroscopy (EDS) system. Specimens were observed uncoated and images were taken in variable pressure back-scattering mode (BSE) with chamber air pressure of 40Pa, at an acceleration voltage of 20.0 kV. The spectra acquisition was done in the same conditions with the detector set at ca. 8-9 mm distance from the specimen surface.

μ-Raman spectroscopy

Micro-Raman analysis was performed using a HORIBA XPlora Raman spectrometer, equipped with a 638 nm diode laser and coupled with an Olympus™ microscope. The system uses a thermo-electrically cooled charge-coupled device detector (CCD). The calibration of the instrument was performed with the Raman band of a silicon crystal at 520 cm⁻¹. Raman spectra were acquired in the 100-2000 cm⁻¹ region with an exposure time of 30 s and 10 accumulations. To avoid thermal damage of the samples, their irradiation was obtained through a 50% filter. The instrument itself was controlled using the LabSpec software. The collected Raman spectra were further processed in GRAMS (ThermoFisher Scientific™).

RESULTS AND DISCUSSION

Effect of silica granulometry, firing temperature and paste/ceramic biscuit pre-firing

The effect of silica grain size used for the preparation of the raw powdered glazes was studied at two different temperatures (800°C – FC1 and 950°C – FC2).

The results obtained (Figures in Table 4) show a clear difference in size of the residual non-fused/non-dissolved silica grains in the glaze layer. Silica grains of the two raw batches (coarse- and fine-grained) remain less altered at low firing temperatures (FC1). At 950°C (FC2), especially for the lower size silica grains, the formation of needle-star crystals was observed and these were identified by μ-Raman spectroscopy [6] as cristobalite (Figure 2), a high-temperature polymorph of silica [7]. At this higher temperature and especially for the lower silica grain size glaze, a higher degree of fusion/dissolution of the silica grains into the glaze matrix is visible.

A “clean” glaze layer without any visible silica grains is observed close to the interface, especially evident in the lower silica grain size (FPS500) (Table 4). This clear glaze layer is hypothetically interpreted as a segregation layer caused by the fast filtration of the freshly applied paste (proto-

glaze) induced by the high suction pressure of the porous paste/fired body. This layer was also occasionally found on 16th century Portuguese azulejos.

Table 4: Raw-applied glazed replicas made with different grain size silica fired at different firing cycles.

	Coarse silica (FPS180)		Fine silica (FPS 500)	
	C0	C2	C0	C2
FC1 - 800 °C	Not done			
FC2 - 950 °C				

C0 – applied on unfired paste; C2 – applied on a pre-fired paste at 1000°C
 FC1 and FC2 – glaze firing cycles (picture magnifications are roughly similar)

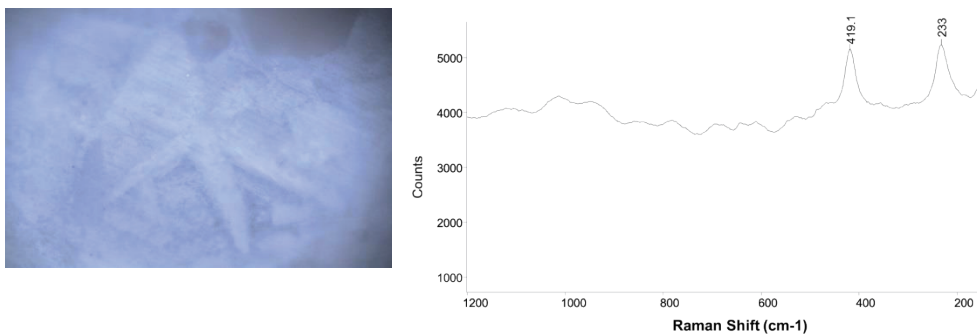


Figure 2: μ -Raman spectrum of the needle-star crystal of cristobalite formed during the firing cycle FC1 (950°C).

Table 5: Raw-applied glazed replicas interface made with different grain size silica fired at different firing cycles

		Coarse silica (FPS180)		Fine silica (FPS 500)	
		C0	C2	C0	C2
FC1 - 800 °C		Not done			
		Not done			
FC2 - 950 °C					

C0 – applied on unfired paste; C2 – applied on a pre-fired paste at 1000°C
 FC1 and FC2 – glaze firing cycles (picture magnifications are roughly similar)

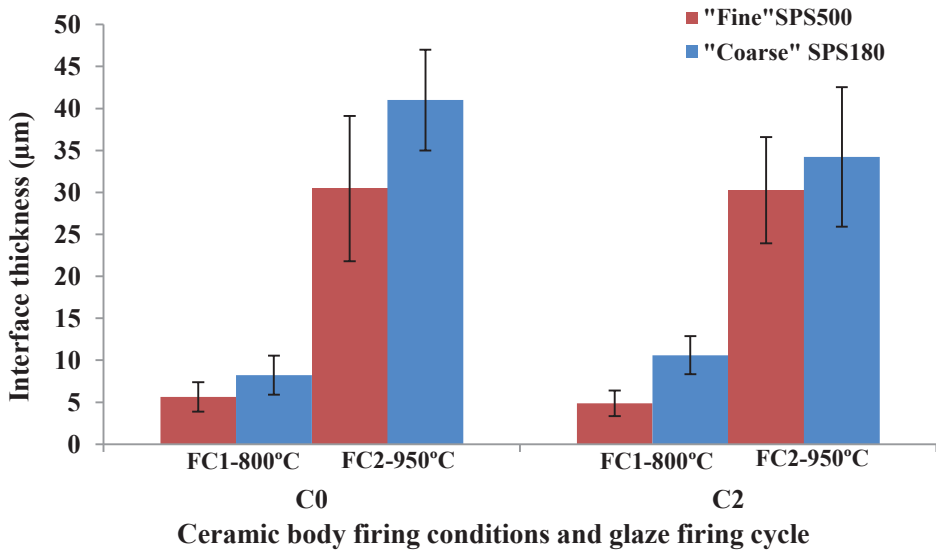


Figure 3: Interface thickness of azulejo replicas prepared with raw-applied glazes prepared with coarse- (FPS180) and fine- (FPS500) grained silica proto-glaze and with firing temperature cycles FC1 (800°C) and FC2 (950°C).

Comparison of “raw” and frit glazing

When fritting a raw glaze, an extra fusion/dissolution of the quartz grains occurs as a consequence of the two-step heating and grinding of the frit. The resulting glaze may show a total dissolution of the quartz grains into the glass matrix or a decrease of their average size (Table 6). A larger increase of the interface thickness is observed when using a raw glaze when compared to its equivalent frit (Table 7, Figure 4). This may be due to a decrease in the effective Pb/Si ratio that happens in the frit glaze as a consequence of its faster fusion and consequent higher Si content in the fused phase. A similar effect occurs when using silica powders with different grain sizes. In the finer grained powder, silica is dissolved faster and at a higher extent resulting in a lower Pb/Si ratio.

Figure 4 compares the interface thickness for the “raw” and frit glazes applied on to an unfired clay body (C0), on to a biscuit fired at 500°C (C1), and fired at 1000°C (C2). The results show that no significant differences exist between the unfired (C0) and fired at 500°C (C1), while a significant reduction in the interface thickness is visible when using ceramic bodies fired at 1000°C.

At the glaze firing temperature of 950°C the formation of needle-like crystals, probably of cristobalite, could also be observed (Table 6).

Table 6: General view of tiles with raw and frit glaze powders prepared with coarse quartz sand FPS180 after glazing at 950°C, using the firing cycle FC2.

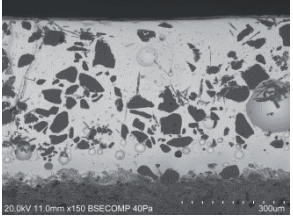
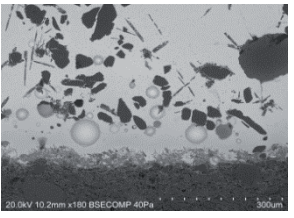
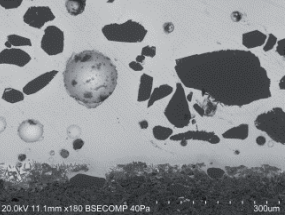
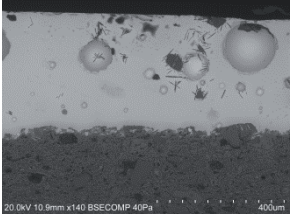
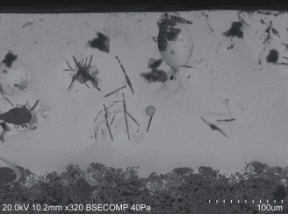
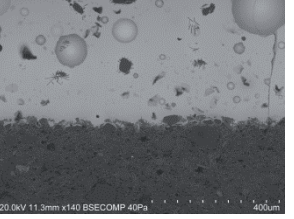
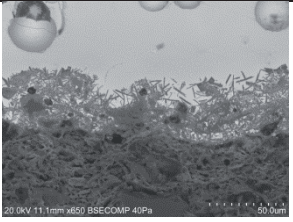
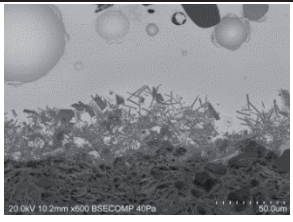
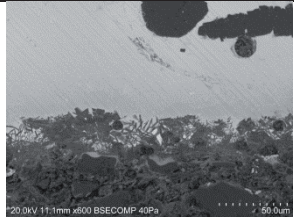
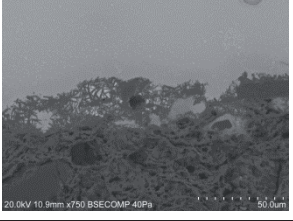
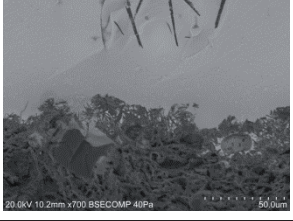
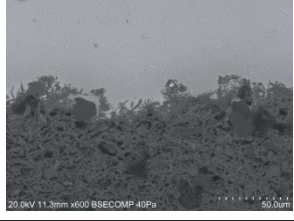
	C0	C1	C2
Raw			
Fri			
C0 – applied on unfired clay body; C1 – applied on a biscuit pre-fired at 500°C; C2 – applied on a biscuit fired at 1000°C (picture magnifications are roughly similar)			

Table 7: Interface of tiles with raw and frit glaze powders prepared with coarse quartz sand FPS180 after glazing at 950°C, using the fire cycle FC2.

	C0	C1	C2
Raw			
Frit			

C0 – applied on unfired clay body; C1 – applied on a biscuit pre-fired at 500°C; C2 – applied on a biscuit fired at 1000°C (picture magnifications are roughly similar)

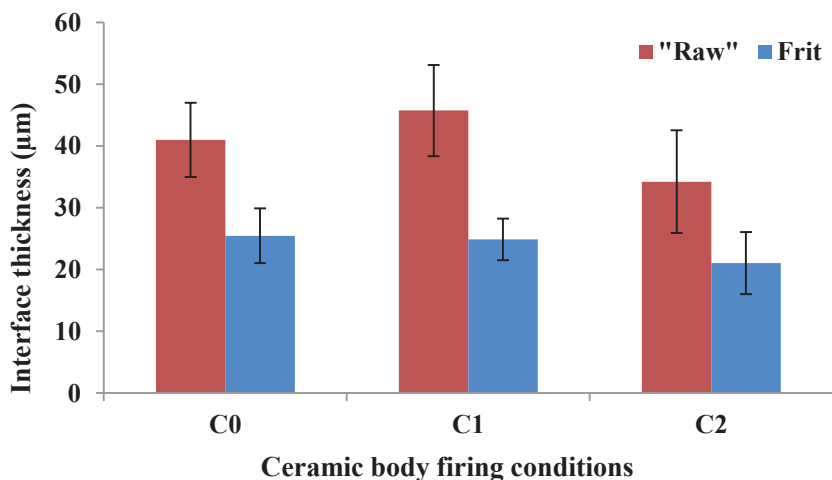
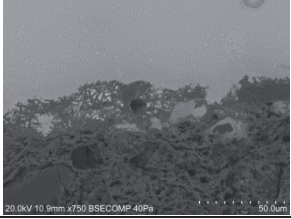
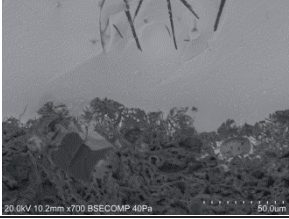
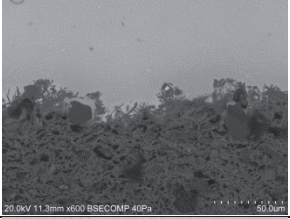
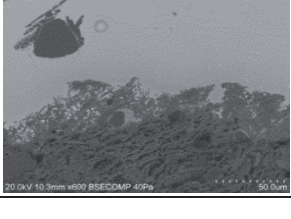
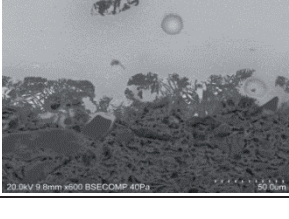
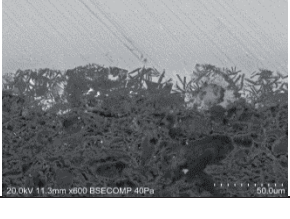


Figure 4: Interface thickness of azulejos prepared with raw and frit glazes with FPS180 silica granulometry and at a maximum firing temperature of 950°C (firing cycle FC2).

Effect of slower and faster firing cycles

When analysing the results obtained for the fritted (FC2 fast cooling and FC3 slow cooling firing cycles) a slight increase of the interface width is observed, as made evident by the presence of Pb-rich K-feldspar crystals. This effect is slightly more evident when the biscuit was fired at 1000°C (Table 8 and figure 5).

Table 8: Interface of azulejos prepared with a frit glaze after being fired at 950°C according to fire cycle FC2 (slower) and FC3 (faster).

	C0	C1	C2
FC2 - Fri			
FC3 - Fri			

C0 – applied on unfired clay body; C1 – applied on a biscuit fired at 500°C; C2 – applied on a biscuit fired at 1000°C (picture magnifications are roughly similar)

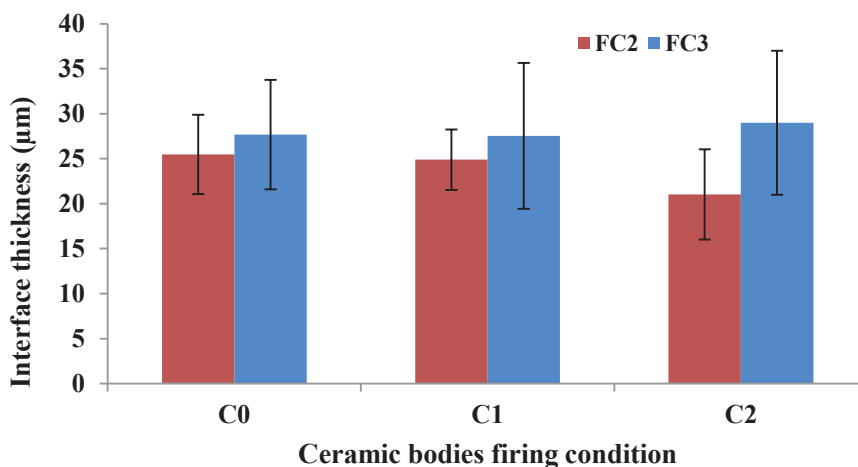


Figure 5: Interface thickness of azulejos prepared with a frit glaze after being fired up to 950°C using the firing cycles FC2 (slower) and FC3 (faster).

CONCLUSIONS

The effect of firing conditions and glaze-biscuit preparation on the lead-tin azulejos interface morphology has been researched. Our study showed that the cross-sectional thickness and chaotic appearance of the glaze-biscuit interface layer does not, in itself, mean that the tile was single-fired.

Under the test conditions, the interface formed reached higher thickness for higher firing temperature and when using a “raw” vs a frit glaze as well as with a coarser silica powder. Slower heating/cooling rates and the use of single (C0) and partial (C1) pre-firing temperatures also led to higher interface thickness.

These morphological modifications are accompanied by significant chemical changes at both the glaze and ceramic levels, which may help to understand better the interactions between them. These aspects are currently under research and will be communicated in future papers.

Acknowledgements

S. Pereira acknowledges FCT, the Portuguese Foundation for Science and Technology, for her Post-Doc Grant (SFRH/BPD/116807/2016).

Communication produced as an outcome of Project FCT-AzuRe - Estudos no Azulejo Português para Candidatura a Património da Humanidade (PTDC/EPH-PAT/5096/2014) also funded by FCT.

Bibliographic references

- ¹ GULOYAN, Yu. A, Diffusion-chemical interactions in glasses of the system $K_2O-PbO-SiO_2$, Glass and Ceramics Vol. 67, Nos. 7 – 8, 2010
- ² MOLERA, J., Pradell T., Martinez-Manent, S. and Vendrell-Saz, M., The growth of Sanidine crystals in the lead of glazes of Hispano-Moresque pottery, Applied Clay Science, 7, 1993, 483-491.
- ³ TITE M. S., Freestone I., Mason, R., Molera J., Vendrell-Saz M., N. Wood, Lead glazes in antiquity – Methods of production and reasons for use, Archaeometry 40, 2 (1998). 241-260.
- ⁴ MOLERA J, Pradell T, Salvadó N, Vendrell-Saz M, 2001, Interactions between clay bodies and lead glazes, J. Am. Ceram. Soc., 84, 5, 1120-28.
- ⁵ WALTON, Marc Sebastian, A., Materials Chemistry Investigation of Archaeological Lead Glazes, PhD thesis, 2004, University of Oxford.
- ⁶ FREZZOTTI, Maria Luce, Francesca Tecce, Casagli, Alessio, Raman spectroscopy for fluid inclusion analysis, Journal of Geochemical Exploration, 112 (2012) 1–20.
- ⁷ BATES, John B., Raman Spectra of α and β Cristobalite, J. Chem. Phys., 57, 4042 (1972).

Understanding 17th-18th century Dutch Tin-glaze Through the Interpretation and Reconstruction of Historical Recipes

Kate van Lookeren Campagne

University of Amsterdam, Amsterdam, The Netherlands, k.e.vanLookerenCampegne@uva.nl

Luc Megens

Cultural Heritage Agency of the Netherlands, Amsterdam, The Netherlands,

L.Megens@cultureelerfgoed.nl

Maarten van Bommel

University of Amsterdam, Amsterdam, The Netherlands, M.R.vanBommel@uva.nl

SUMMARY: The interest in technical art-historical sources has grown in recent years as has the awareness that they are invaluable in improving our knowledge and understanding of both the composition and degradation of art objects. This research has centred on the interpretation of Dutch 17th and 18th century tin-glaze recipes as described in contemporary, written sources. Research into the raw materials described in the recipes combined with EDX analysis of a reference group of historical tiles enabled the reconstruction of a historical glaze, the beginning of an ongoing project that is exposing new information on the nature of the fluxes used in the recipes, in particular the sodium components. The findings expand our understanding of the glazes used on Dutch tin-glaze tiles and objects.

KEY-WORDS: Tin glaze; Historic glaze recipes; Glaze reconstruction

INTRODUCTION

Researchers of historical Dutch tin-glazes are extremely fortunate in having both hand-written and published indigenous historical sources which document 17th and 18th century tin-glaze recipes as well as providing information on the production of both tin-glaze household wares and tiles. The findings presented in this paper are part of a broader PhD research into the production of Dutch tin-glaze tiles in the 17th and 18th century. While there is evidence in de archival documents that specific clay mixes and glazes were used in tile production, one has to consider tin-glaze recipes in a broader context. Although a number of productions specialised in tile production, many Dutch factories produced both tiles and household wares. An initial step in the assessment and interpretation of indigenous Dutch tin-glaze recipes is to compare them with other European written sources describing tin-glaze recipes, some of which claim to document recipes from Delft.

HISTORICAL TIN-GLAZE RECIPES

The earliest records of tin-glaze recipes

Although the treatise written by Abu'l-Qasim in 1301¹ is considered to be the earliest text relating to tin-glaze technique, the glazes discussed are compositionally closer to alkali frit glazes. Of greater

relevance is the three-part manuscript ‘The Book of the Potter’s Art’ written by the Italian Cipriano Piccolpasso (1524-1579) in circa 1558.² Piccolpasso was known to have had contact with Flemish potters and there is an evident similarity between some of his recipes and techniques he documents and those found in the Dutch sources a hundred years later. Interestingly, Vannoccio Biringuccio’s published a few years earlier in 1554,³ describes tin-glaze recipes very similar to those found in Piccolpasso. This either suggests that Piccolpasso had taken recipes from Biringuccio’s publication, or that similar recipes were used throughout Italy at the time. A simplified overview of these recipes can be found in table I.

AUTHOR	DATE	‘MASTICOT’ (M)	Proportional W% in masticot	‘TINAS’ (TA) LEAD: TIN (weight before calcination)	Prop. w% tinas	FINAL GLAZE MIX M:TA
Biringuccio, Vannoccio	1540	3 sand: 1 wine lees	10: 3+	100: 20	5: 1	Albertus’ 3: 1
Picolpasso ‘common white’	1558	30 sand: 12 wine lees	10 : 4	17 : 12	5: 4	50: 30 + 8 salt
Diderot	1756	[1] 150 Nevers* sand [2] 80 sand: 50 soda *known to have a high CaCO ₃ w%	10 10: 6.2	100: 20 50: 50	5: 1 1 : 1	150: 100 + 25 salt

Table I: Early historical tin-glaze recipes

Recipes specifically relating to Dutch tin-glaze production

Indigenous Dutch sources that document historical Dutch tin-glaze recipes have been mentioned in previous publications⁴. The most quoted text relating to Dutch tin-glaze production is Gerrit Paape’s treatise ‘De Plateelbakker of Delftsch’ published in 1794⁵. Paape (1752 – 1803) worked as an apprentice decorator in a Delft faience factory from the age of 13 for a number of years, after which he worked as a journalist and writer. In this treatise he describes the materials and techniques used in the Delft faience industry at that time. However, arguably the most significant historical source regarding Dutch tin-glaze recipes is a 160-page parchment-bound, hand-written notebook kept in the archive of the Museum Hannemahuis in Harlingen⁶ (see figure1). The notebook was written between 1712 and 1720 by Petrus Sijbeda (ca.1670 - ca.1721) a factory-owner from a family of Harlingen potters. In the notebook Sijbeda documents over 80 recipes from his father and other factories for tin glaze, coperta (lead) glaze (*kwaart*), on-glaze colours and kiln glaze (*binnenverf*), as well as providing recipes for clay mixes suitable for tiles (*stenen*), tableware (*schuttels*) and kiln bricks (*boogstenen*). The glaze recipes he describes are primarily from Harlingen, but some are also attributed to other production centres, notably Delft, Utrecht, Rotterdam, Makkum and even England. In certain cases the specific potters’ names that are linked to glaze recipes have been shown to be historically accurate. Many recipes are also dated, ranging from 1659 to 1720. Sijbeda describes the quality of the different glazes and clay mixtures and often the source and cost of materials. Another similar written source that is only available in transcript is the hand-written oven-book of another Harlingen potter Sijbrand Feitema⁷ dated 1725. Figure 1 shows two recipes dated 1672 and 1674.

Historical Dutch tin-glaze recipes can also be found in other European written sources (see Table II). The recipes are generally attributed to Delft which was the most important centre of faience

production at the time. The German scientist, alchemist and glass maker, Johann Kunckel, (1637?-1703), published a treatise in 1679 in which he provides 60 recipes for glass and glaze, allegedly collected in the Netherlands.⁸ The treatise was translated into Dutch in 1774 by an author under the name of AF, possibly the painter Albertus Frese (1714 – 1788)⁹. Information from Kunckel’s treatise was used for Diderot and d’Alembert’s entry on ‘Fayence’ in the well-known ‘Encyclopédie’ published in 1756¹⁰.

AUTHOR	DATE	'MASTICOT' (M)	Proportional W% in masticot	LEAD: TIN (T) (before calcination)	Prop. w% tinas	FINAL GLAZE MIX M:T
Kunckel 'Delft'	1689	100 sand: 30 soda: 40 wine lees	10 : 3 : 4	100 : 33	3:1	100: 80 + 10 salt
Sijbeda (average of recipes)	1721	[1] 300 sand: 60 soda ¹ : 36 potash [2] 300 sand: 100 soda ² ¹ Alicante soda ² 'English' soda	10: 2: 1 10 : 3	200: 60	3:1	100: 66 + 22 salt
Diderot 'Blanc de Hollande'	1756	50 sand : 20 soda: 15 potash (+ 6 oz. manganese)	10 : 4 : 3	20 : 20	1:1	100 : 40
Frese Albertus (Translation of Kunckel)	1774	100 and: 30 soda: 40 potash	10 : 3 : 4	100 : 33	3:1	100: 80 + 10 salt (+ cobalt and copper filings)
Paape	1794	500 sand: 30 soda: 60 salt	10 : 0,6: 1,2	10: 3	3:1	65: 50 (+ 0,5 smalt and copper filings)

Table II: Historical ‘Dutch’ tin-glaze recipes

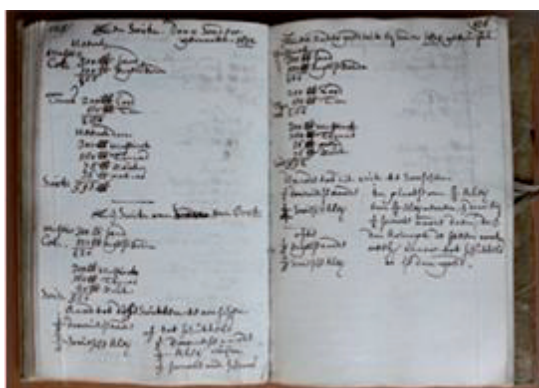


Figure 1: Page 25 of Petrus Sijbeda’s recipe book with Harlingen tin-glaze and clay-mix recipes dated 1672 and 1674

Dutch Tin-glaze recipes in historical context

Looking at the historic recipes one is struck by the similarities in terminology and composition, despite the fact that the recipes cover 250 years and are from authors from different countries that have quite different backgrounds and experience with the ceramic industry. Almost all the sources describe the tin glaze as being made from two compounds which were made separately: the first is a glass frit (*masticot* in Dutch, *marzacotta* in Italian) and calcined lead and tin (tin ash or *tinias* in Dutch but only vaguely referred to as tin or *latta* in Italian). *Masticot* was a mixture of sand (primarily quartz) and flux (soda and/or potash and occasionally common salt), which was melted on the bottom of the main kiln before being broken up and ground into a powder to make a frit. The second lead-tin mixture (*tinias*) was produced from lead and tin metal blocks which were weighed to specific proportions before being calcined in a separate *tinias oven* or tin kiln (a separate kiln was necessary due to the emission of sulphur that would affect the glaze firing). The *masticot* and *tinias* powders were then combined, usually with added salt and/or potash, before again being melted on the bottom of the kiln (in a crucible in Italy and piled within a ‘wall’ of *masticot* powder in the Netherlands¹¹). The melted mass was then milled, mixed with water, and applied to the fired ceramic.

The glaze recipes were all measured in weight, generally in pounds (lb). The weights are proportional as weight measurements, (measurements in ‘pounds’ would have varied between countries and even cities). The *masticot* mixes appear to fall into two main groups. In the Italian recipes, the proportion of sand to flux in the *masticot* is around 10: 4. This is similar in Sijbeda’s recipes. However, while Paape’s *masticot* recipe contains far less flux, the proportion of flux in Kunckel’s ‘Delft’ recipe is double that of the first group. This is reflected in Diderot’s and Albertus’ ‘Dutch’ recipes, which is not surprising considering that they sourced their information from Kunckel. Kunckel’s ‘Delft’ recipe is made even more questionable as it describes the use of wine lees (also known as tartar), the source of potash used in the wine-producing regions of the south. Also, the proportions of *tinias* to *masticot* in Kunckel’s final glaze recipe is exceptionally high.

The proportional weight of lead and tin used to produce the *tinias* in the Dutch recipes is less variable, consistently giving proportions of 3:1 of lead and tin. The one exception is found in Diderot who documents the use of equal proportions, also seen in some of the earlier Italian recipes, which may suggest a lower tin purity. While it appears possible to divide the documented historical tin-glaze recipes into groups, one must be aware that these are simplified recipes. Piccolpasso describes a number of recipes from different Italian regions, which vary considerably, assumedly due to variations in the raw materials from the different geological areas.

INTERPRETING 17TH & 18TH CENTURY DUTCH TIN-GLAZE RECIPES

Having demonstrated that the Sijbeda tin-glaze recipes make sense within an historical framework, the next step was to attempt to interpret the meaning of the terms used in the recipes in order to understand the composition of the materials they describe. To do this one has to consider the sources and availability of raw materials at the time as well as the methods of extracting and refining these raw materials, taking into account probable variations in quality.

Sand

Sand provides an easily available source of silica (SiO₂) for the production of glass and glaze. Sand is ground stone with a grain size varying from 0,125mm for very fine sand (125µm) up to 1mm for coarse sand. In general sand consists primarily of silica due to silica’s chemical inertness, hardness, and resistance which results in a slower process of weathering. Sand often

contains other common elements such as iron (Fe_2O_3), calcium carbonate (CaCO_3) and feldspar (aluminosilicates rich in K, Na or Ca). Such impurities may not only affect the colour of the final glaze, but also function as fluxes at higher temperatures, (especially feldspar and calcium). In the historical recipes we see that Diderot recommends the use of sand from Nevers which is known to have a high CaCO_3 w%. Sijbrand Feijtema mentions that sea sand was used in the Harlingen factories, commenting that sand from Terschelling (an island in Friesland) produces a poorer product than sand from The Hague (also known to have a high CaCO_3 content).

Soda

The Dutch recipes all contain soda or *zouda*. The term soda suggests that the material being added was sodium carbonate, a common product that was easily available. Soda had been produced and traded for centuries to make soap, to bleach textiles and to make glass.

Barilla

The earliest European glassmakers of Venice sourced soda from salt-tolerant (halophyte) desert or sea plants of the genus *Salicornia*, such as *Salsola soda*, known as *barilla*, from the salty morasses of the Mediterranean Sea. The best quality *barilla* comes historically from Alicante in Spain¹². *Alicante zouda* is specifically mentioned in a number of the early glaze recipes in Sibeda's notebook¹³. *Salsola soda* contains a relatively high sodium carbonate content (30 – 40%) together with some potassium, calcium and magnesium carbonates¹⁴.

Kelp

In the early period of tin-glaze production in the 16th to mid-17th century the main source of soda to make glaze would have been imported barilla. From the mid-17th century, local sources of sodium carbonate became available in Northern Europe extracted from seaweed, primarily from cold-water seaweed from the Laminariaceae family, known as *kelp*, and the *Fucus* family, known as *wrack*. Sijbeda specifies the use of *engelse soda* (English soda). One can assume that this refers to soda produced from kelp. These recipes date from about 1670 which is the period that the kelp industry in Britain was rapidly developing.¹⁵ Kelp was first harvested and calcined by burning in the Scilly Islands but during the 1700's Scotland became the main supplier.

In 1750 Sijbrand Feytama described glaze recipes containing both *Alicantsche zouda* and *Schotsch soda* (Scottish soda). In the same period Diderot provides a recipe for *English white* (tin-glaze) using soda made from Normandy seaweed¹⁶. The amount of sodium carbonate that can be extracted from kelp or wrack is far lower than from Barilla. Robert Brill analysed a number of North Sea wrack samples¹⁷ concluding that they produced equal amounts of Na and K (oxides), which constituted between 29.2-40.7% of the total ash. Similarly, there were equal amounts of Ca and Mg oxides (10.7-22.8% of the total ash). He referred to the glasses produced with kelp as a flux as being 'mixed-alkali'.

In the Sijbeda recipes containing Alicante soda, not only is the w% of soda generally lower, but potassium in the form of *pot-as* (potassium ash) or *wied-as* (plant ash) is always added, resulting in a similar mixed-alkali glaze frit. In 1823 Feytama commented that one only has to use half the Alicante soda as it is not as 'fat' as the Scottish soda. Brill mentions the fact that there would have been variations in the composition of kelp or wrack depending on where and how it was harvested and at what time of year¹⁸. The fact that it was a question of trial and error can be seen in a Sijbeda recipes dated 1718 where different percentages of English soda are recommended depending on whether the soda is 'strong' or 'weak'. Similarly, year later in 1719 a higher percentage of soda in a recipe is explained by the fact that the soda is 'weak'. Sijbeda states that

if the soda used was of poor quality, the glaze would be ‘dry’, presumably meaning that it would lack shine.

Potash

Potash (K) is used in glass and glazes in the carbonate form (K_2CO_3), known as pearl ash or in the form of tartar. Wine lees, or ‘cream of tartar’ is a by-product of winemaking and a common source of potassium in winemaking regions, primarily consisting of Potassium bitartrate ($KC_4H_5O_6$)¹⁹. Piccolpasso discusses three types of deposits that accumulate in wine barrels: tartar, argol, and lees. Ashes of wine lees can contain as much as 90 % potassium carbonate²⁰. Potash is also obtained in the form of potassium carbonate or potassium hydroxide from wood ash (generally beach, pine or birch) and other plants such as ferns and bracken²¹. The *wied-as* or *pot-as* mentioned in Dutch sources suggests that potash was sourced from wood ash or ferns.

Lead

Lead oxide (PbO) has been used to create glazes for thousands of years. It is easy to apply and forms a glass at a low temperature. To produce the *tinas*, lead and tin metal blocks were heated in a separate (*tinas*) oven with tin. When pure lead is heated a yellow, amorphous powder forms on the surface known as litharge (lead(II)oxide). This was scraped off as it formed in the kiln. The Dutch terms for litharge were *loodglit*, *goudgelit* or *loodas*. Sijbeda shows that that lead metal was obtained from different sources and was of different qualities. As well as *lood* (lead), he mentions the use of *theelood* (tea lead from tea chests) and *oude plat lood* (old lead sheet). In the pure lead-glaze or *kwaart* recipes, the use of *goudgelit* (litharge) was always specified.

Tin

As with lead, potters calcined tin metal in an oven to make tin oxide (SnO_2). The sources of tin were limited in the 17th and 18th century. The high quality of the tin from Cornwall in England had been known since the Romans and is mentioned by both Piccolpasso and Sijbeda. Sijbeda describes variations in the quality of tin used for the glazes using the terms *fijne tin* (good quality tin) and *keur tin* (standard quality tin). He states that after English tin, the next best quality was from the province of *Holland* (two provinces in the west of the Netherlands) and the poorest from local suppliers in *Friesland* (the province in which Harlingen is situated). The different quality of glazes recorded by Sijbeda, ranging from *sleght* (poor) to high quality *wit wit* (white, white), appears largely related to the proportion of tin. Sijbeda noted that the best quality tin glaze has such a high proportion of tin that it is too expensive to be practical, although he later comments that it is worth using a good quality glaze as the wares can then be sold for a higher price. Tin was probably the most expensive ingredient in tin-glaze and potters did their best to use as little as possible.

Figure 2 shows the w% of tin used in the dated glaze recipes in Sijbeda. The quantities refer to the tin in its metal form before calcination as a percentage of the final glaze mix. The final amount of litharge produced would have been dependent on the purity of the tin used. Taking into account the weight change during calcination, the tin w% is seen to range between 7 and 11. In the two recipes where a lower tin w% is documented, one (A) is said to be of poor quality and the other (B) used for an unmixed clay with a lower $CaCO_3$ content. In the one example where a high percentage of tin is used (C), impure tin solder was used. Interestingly, while the w% of tin metal appears to remain fairly consistent in the recipes, proportion of *tinas* used in the final glaze mix (as seen in the recipes) appears to increase slightly over time, possibly suggesting that the quality of the tin used may have decreased.

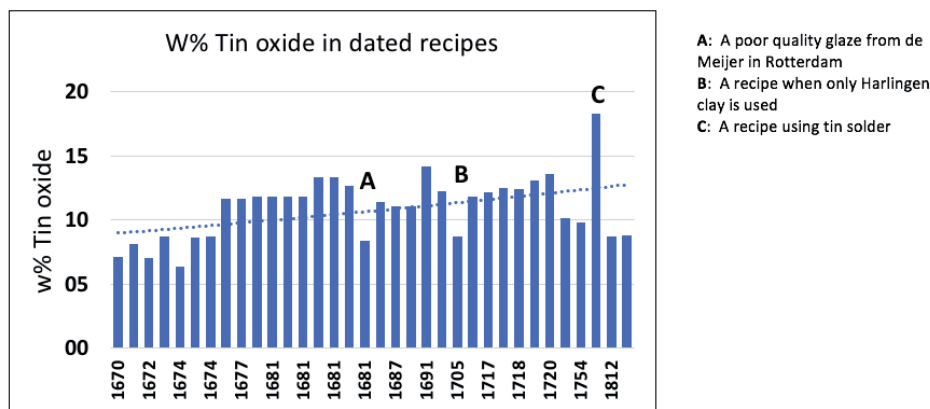


Figure 2: The w% of tin (metal) calculated from the (dated) recipes in Sijbeda's recipe book 1670 - 1812

Salt

When the ground *masticot* and tin powder were combined to make the glaze, common salt or *zout* was generally added before the glaze mix was melted at the bottom of the kiln. The proportion of salt used in the final glaze mix in Sijbeda's recipes remained consistently around 8 w% in the later recipes. Salt is found in almost all historical tin-glaze recipes including those in Pilcolpasso, Diderot and Kunckel We know that the 'salt' referred to is sodium chloride due to the fact that it is often referred to as 'sea salt'. Of the 76 glaze recipes in Sijbeda only three recipes do not include salt in the final mix. These, including the oldest dated recipe dated 1659, are all referred to as being poor quality glazes. Only two recipes in Sijbeda dated 1812 and 1815 include salt in the *masticot*, as does the recipe in Paape.

There does not seem to be an explanation as to why salt was added. Logically it would have been added to as a source of the flux sodium. However 'soda' was already available and used for the *masticot* (sourced from kelp or barilla). One consideration is that the salt was cheaper, but the references to the advantages of using imported Portuguese salt from St Ubes show that cost was not the main issue. Bastenaire-Daudenart²² even states that while one can replace the soda with sea salt, the sand will not fuse as well with salt as with Alicante soda. The different chemical formulations of salt and soda result in different reactions in the kiln. NaCl melts at 801 °C at which point chlorine gas is emitted, a reaction that occurs fairly quickly. Sodium carbonate (Na₂CO₃) melts at 851 °C and undergoes thermal decomposition resulting in the formation of NaO and CO₂. This process is slower, possibly providing more time for the sodium to react with the silica.

Salt is clearly considered to be of an advantage in the glaze mix. At one point Sijbeda claims that the proportion of salt is responsible for the whiteness of the glaze. This idea was supported elsewhere by Bastenaire-Daudenart when he claimed that (common) salt was more important than soda or potash for the production of tin glaze. Franchet was still supporting this idea in 1911.²³ Bastenaire claims that, although soda works better as a flux, salt has the advantageous property of bleaching the glaze. He suggests that the reaction on heating and consequent emission of hydrochloric acid results in fusion of the tin, lead and silica, as well as the elimination of unwanted substances in the glaze, thereby 'retaining the beauty of the product.' He appears to suggest that a reaction occurs that 'dissolves' unwanted discolouring material in the glaze. This idea is supported by Prudence Rice,²⁴ who states that sodium chloride in a glaze mix results in the vaporisation of traces of iron oxide with chlorine emissions during firing. The quality of the salt is also shown to have been an issue. In 1770 Tjallingii complains that plates and tiles were

discoloured *vol blauw* (completely blue) due to the use of *allemattes zout* (common salt) rather than imported sea salt from St Ubes in Portugal.

Colourants

Both Albertus and Paape mention the addition of small amounts of cobalt oxide in the form of smalt and copper filings in the Delft glazes. It is presumed that this was done either to whiten a yellow-tinted glaze, or to attempt to achieve a colour closer to that of Chinese porcelain glazes.

COMPARISON OF THE RECIPES WITH THE PHYSICO-CHEMICAL ANALYSIS OF DUTCH TIN-GLAZE TILES

Another means of assessing the glaze recipes in the source documents is by comparing the composition described in the recipe with data on the elemental composition of Dutch historic tin-glaze tiles from the period under study. A set of historical tiles was selected with a range of manufacture dates and production centres (see figure 3).

	1600 - 1620	1620 - 1640	1640 - 1660	1660 - 1700	1700-1750
ROTTERDAM					
HARLINGEN					
UTRECHT					

Figure 3: Overview of tile selection analyzed with SEM-EDX

The provenance of Dutch tiles is notoriously problematic, and the primary criteria was to find tiles where the centre of production could be determined with as much certainty as possible. The determination of provenance was made based on the decorative style, documentation, the history of the building where tiles had been removed, or excavation data. The tiles were acquired on loan from museums or private collectors. Kiln waste from Harlingen and Rotterdam was also sourced. Three specific production centres were chosen: Rotterdam, Harlingen and Utrecht. Apart from being important production centres, Rotterdam and Harlingen were chosen due to the fact that the majority of historical archival sources are linked to these cities. Delft tiles were not chosen as Delft was not a major producer of tiles, quickly specialising in faience objects. In addition, provenance of early Delft tiles is notoriously problematic.

SEM-EDX ANALYSIS

Scanning electron microscopy (JEOL 9510LV E) coupled with an energy-dispersive X-ray detection system (Thermo Noran system 6) was used to obtain microstructural and elemental characterization of the tile set. The analysis was performed at low vacuum (30 Pa), 10-20 kV high voltage and a working distance of 10 mm. All cross-section samples were imaged in back-scatter mode which provided information on the morphology of the glazes. Semi-quantitative data on the elemental composition of the glazes was obtained with energy-dispersive X-ray detection. Concentrations are reported as oxides of elements as ceramics and glass materials primarily contain elements in the form of oxides.

Sampling

Three samples of about 1 mm (the samples included both the glaze and ceramic body) were taken from different areas of each tile using a drill with a 1 cm diamond disk. The samples were embedded in Epofix epoxy resin and polished using silicon carbide paper to 4000 mesh. EDX measurements were taken of three areas of the glaze and the average calculated.

Results

The back-scattered SEM images (see figure 4) show examples of how the homogeneity of both the glaze and ceramic tile improved during the 17th and 18th century. The EDX data of the glaze composition was normalised to take into account the influence of the epoxy embedding material on the C and O measurements. Figure 5 gives an overview of the w% of the composition of the historic tile glazes dated between 1600 - 1750 as oxides (SiO_2 , PbO , SnO_2 , Na_2O , K_2O , and CaO). Although the elemental composition is seen to vary, certain patterns can be observed. The w% of silica remains fairly constant at +/- 50%, K_2O at 3- 5 %, Na_2O at 2 - 3% and CaO at 4%. The SnO_2 w% is variable, ranging from 6 – 12w%. There appears to be a slight increase in the w% of tin over the period which could be seen to reflect the increase seen in the Sijbeda recipes in figure 2.

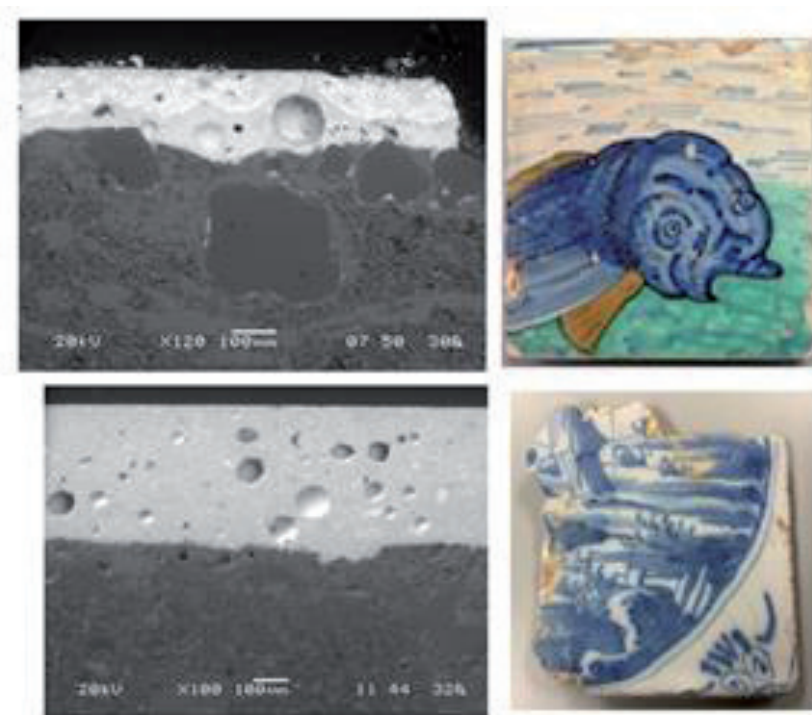


Figure 4: SEM backscattered images showing the examples of the glaze and ceramic morphology of Dutch tiles in the period: Rotterdam +/- 1620 (above), Utrecht +/- 1720 (below)

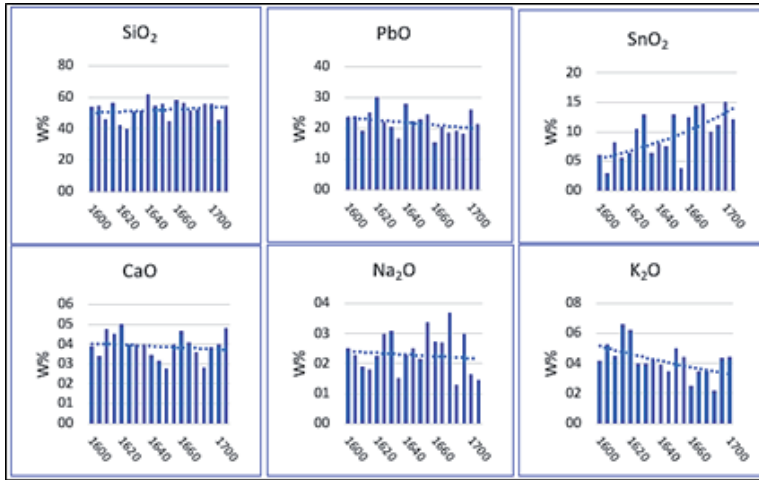


Figure 5: A comparative overview of the w% of major elements (reported as oxides) in the reference group of Historical Dutch tin-glaze tiles from 1600 – 1720 (*SEM-EDX, JEOL 95 10LV E, low vacuum 30pa*)

RE-INTERPRETATION AND RECONSTRUCTION OF A RECIPE – A PILOT STUDY

The information gained from research into the raw materials and the chemical analysis of the historic tile glazes was used to re-interpret one of the Sijbeda glazes in order to make a glaze reconstruction. The aim of the reconstruction was to assess in how far the new information regarding the raw material composition could be supported.

‘A good glaze from my father’

The re-interpretation of a recipe

The glaze recipe chosen for reconstruction was a Harlingen recipe from page 9 in Petrus Sijbeda’s glaze book (see figure 6). Sijbeda writes that the recipe was used by his father to make tiles ‘*bij mijn vader tot de fijn steentjes gebruikt*’ (used by my father to make good quality tiles). The composition of the recipe was calculated taking into account the interpretation of the ‘soda’ as a mixed-flux. In addition, 6,0 w% CaCO₃ was added to compensate for the 4% CaO found in all the historical glazes (which would have been present in the kelp ash and possibly also the sand). When using the EDX results of the fired glazes to calculate a raw glaze recipe, the calcium, sodium and potassium oxides had to be recalculated to represent the carbonate form in which they were present in the raw materials. Similarly, the slight difference in w% between the lead and tin metal proportions once they were calcined had to be taken into account. The composition of the glaze that would result from the re-interpreted recipe was compared with the average chemical composition of historic glazes (see table III). As can be seen, the interpretation of the ‘soda’ as a mixed-flux brings the composition closer to that of the analytical results of historic glaze, although the sodium w% appeared still somewhat higher in the recipes than in the historical glazes. The main reason for this is considered to be the impurity of the *soda* and the fact that the kelp would not have consisted of pure carbonates.

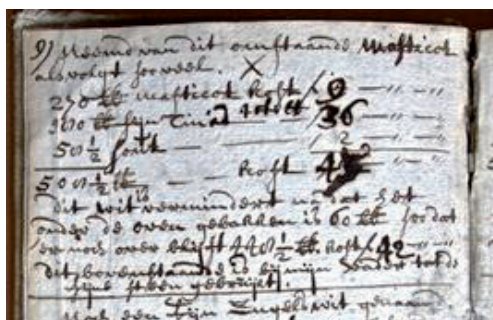


Figure 6: Recipe on page 9 of Sijbema’s recipe book described as a glaze ‘used by my father for good quality tiles’

	Composition and source	Recipe in Text (in lb) (fluxes as carbonates)	Calculation of glaze - adjusted to known raw materials (fluxes in recipe calculated to oxides)	Recipe + 6 - to match the quartz w% in the EDX results (oxides)	Average w% from EDX of historic tiles (oxides)
MASTICOT					
'zand'	Impure quartz	300	300	50	50
'soda'	Kelp +/- 50:50 Na ₂ CO ₃ /K ₂ CO ₃	200 carbonates in recipe = 126 lb oxides	63 Na ₂ O	10,5 (includes 4% from salt) = 6,5	2,5
			63 K ₂ O	10,5 (- 4% CaO?) = 6,5	
CaCO ₃	calcium in sand or plants	Not in recipe	(4% CaO = 6,8 CaCO ₃)	+4	4
TINAS Glaze mix = 3:2 masticot: tinas (66%)					
'lood'	Lead (metal)	200 (Calcination x 1,08)	(216)	24 66% 216 / 6)	22
'tin'	Tin (metal)	100 (Calcination x 1,27)	(127)	13 (66% 127 / 6)	6 - 12
Added to final glaze mix					
'zout'	NaCl	65 (11,5%)	65 NaCl = 34,5% Na ₂ O	4 % Na ₂ O	-

Table III: Calculation of the ‘good’ Sijbema recipe

The glaze reconstruction

The glaze reconstruction protocol followed the historical processes as closely as possible within the feasible health and practical and health and safety limitations. The glaze was produced made in two stages as described. The process of calcining tin and lead in an open oven was not

attempted due to health and safety issues. Silver sand that contained less than 1 w% iron and calcium was used as the *zand* in the recipe. The sand was analysed shown to contain less than 1w% Fe₂O₃. The grain size varied between 150 and 250 microns. Pure sodium and potassium carbonates were used for the *soda* as a mixed flux and calcium carbonate was used for the calcium. The *tinas* was made up from pure litharge (PbO) and tin oxide. Sea salt was used for the *zout* in the recipe. When calculating the ingredients, the lead and tin quantities had to be recalculated as the recipes refer to the metal state whereas the oxides created by calcining were used for making the final glaze mix. Table III shows how the glaze recipe was calculated and compared with the expected fired glaze composition as well as the average of the EDX analysis results of historical Dutch tiles glazes (see Figure 5). The calculations were based on the raw materials being pure.

MAKING THE MASTICOT AND FINAL GLAZE

The melting of the *masticot* and glaze mixes was undertaken in a well-ventilated gas kiln. The components of the *masticot* recipes were mixed and piled on a bed of sand on the bottom of a gas kiln (see figure 7). The firing protocol was formulated from what is known about the kilns and firing procedures of the period²⁵. The kiln was heated at 100°C per hour up to 700°C and then brought up to 1000°C where the temperature was held for 30 minutes before leaving the kiln to cool naturally. The *masticot* was ground in a granite mortar and passed through a 800 µm mesh. It was then mixed with the *tinas* mixture and the sieving and firing process was repeated. The glaze powder was mixed with demineralized water and applied by pouring to ceramic test tiles that had already been produced from historical clay recipes with CaCO₃ weight percentages of 20, 30 and 40%²⁶ after which the glaze was pared-down to a thickness of 0.8 mm (this was done by drawing a 8mm high glass profile across the glaze). The glaze tests were fired in a vertical position to 980°C.

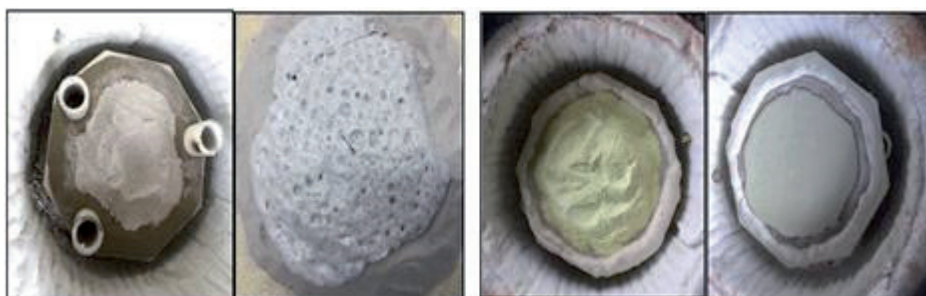


Figure 7: *Masticot* (left) and glaze mix (right) before and after firing

Comparing the glaze tests with historical tiles

Figures 8 and 9 show the results which are now undergoing investigation. As can be seen, it was possible to achieve a successful glaze. The glaze produced on ceramic bodies made with a higher CaCO₃ % is glossier and better vitrified. This suggests that the CaCO₃ in the ceramic body appears to work as a flux for the glaze. Further tests are being undertaken to assess the influence of variation in firing temperature.

When comparing the EDX results with those of an historical Harlingen glaze from the same period as the recipe, the similarity is evident, although the w% of sodium shown after analysis is still too high in relation to that of potassium. In addition, magnesium is missing in the glaze

reconstruction. As the silver sand used was known not contain any significant amounts of magnesium it most probably originated from the kelp. The glaze reconstruction also has relatively large tin oxide crystals a broader glaze-body interface, probably due to the high w% of sodium in the glaze which is a particularly effective flux. Further investigation needs to be undertaken into the composition and crystal formations at the interface.

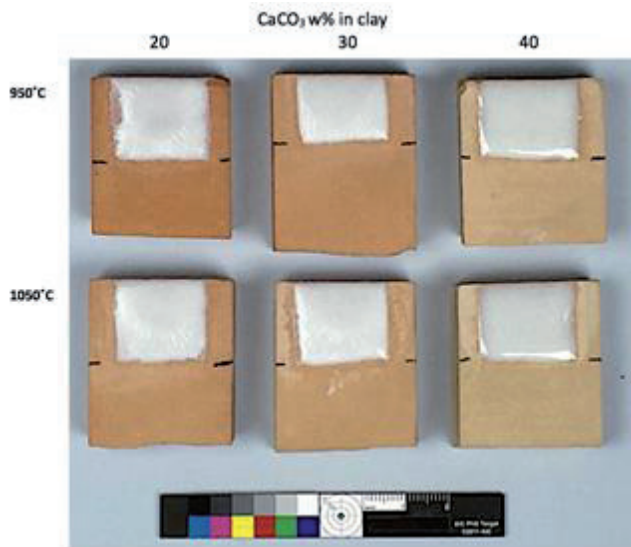


Figure 8: The Sijbada glaze on test tiles (20/30/40 w% CaCO₃ in the clay). The temperatures given are the temperature used for the initial ‘biscuit’ firing of the ceramic test tile.

	Na ₂ O	MgO	Al ₂ O ₃	SiO ₂	K ₂ O	CaO	Fe ₂ O ₃	SnO ₂	PbO
Rabbit tile 1640	3,1	1,3	3,4	53,7	3,3	4,4	0,0	8,2	21,7
Sijbada glaze test 1	6,0	0,0	1,8	53,3	0,5	4,8	0,0	5,7	27,9

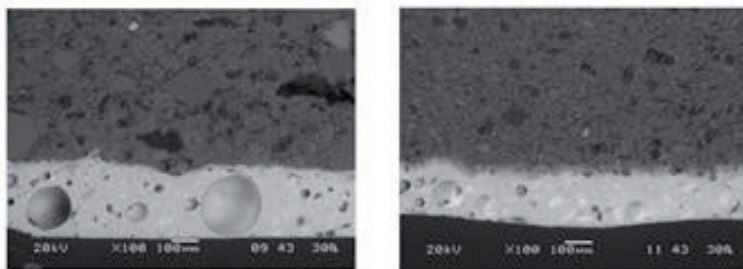


Figure 9: SEM-EDX analysis results of Harlingen ‘Rabbit’ tile dated 1640 compared with pilot reconstruction of Sijbada Harlingen tile glaze recipe (*JEOL 95 10LV E, low vacuum, 30pa*)

CONCLUSIONS

The research into raw materials, recipe re-interpretation, glaze reconstruction and preliminary glaze tests have provided significant new insight into the composition, sources, and influence of the raw materials used in Dutch tin-glaze production. Of particular interest is the source of the 'soda' in historic recipes, which from the later 17th century was extracted from kelp and wrack and would in fact have been a mixture of sodium and potassium carbonate rather than pure soda. Also of interest is the significance of the sodium chloride added to the final glaze mix in most recipes. Both issues are the subject of continuing research and experimentation. When interpreting historic glazes, it is clearly essential to consider the composition within the confines of sources and the purity of the materials described.

The high w% of sodium in the simple glaze calculations is clearly not only due to the fact the kelp ash would not have consisted of pure soda oxides, but also due to the fact that the raw material obtained would have contained unburnt and carbonaceous matter. The variation in the composition of the kelp and wrack extracted at different points in the calendar year is now under investigation. It is thought that the sodium/potassium ratio varied depending when the kelp was harvested which may explain the low w% of the K in the reconstructed glaze.

Bibliographic references

- ¹ ALLAN, J.W. *Abu'l-Qasim's Treatise on Ceramics*. Iran, 11, 1973, pp 111–120.
- ² PICCOLPASSO, C. *The Three Books of the Potter's Art (I Tre Libri Del Arte Vasaiaio)*, 1558 transcript translated and annotated by R Lightbrown, and A Caiger-Smith. London: Scholar Press, Victoria and Albert Museum, 1980.
- ³ BIRINGUCCIO, V. *Pyrotechnia [1554]*. Translated by C. Stanley Smith, M Gnudi, Dover Publications Inc., New York, 1990.
- ⁴ VAN LOOKEREN CAMPAGNE. *Een verkeerde loop in 't vuur: an initial investigation into what Dutch archival sources can tell us about techniques and problems in the production of 17th and 18th century Dutch tin-glaze tiles*, GlazeArch2015, LNEC, Lisbon.
- ⁵ PAAPE, G. *De Plateelbakker of Delftsch Aardewerkmaaker, Volledig beschrijving van alle konsten, aanbachten, handwerken, fabrieken, trafieken, derzelver werkhuizen, gereedschappen, enz., 24 volumes 1788 – 1820, volume 12, Dordrecht, 1794* (facsimile Amsterdam 1978).
- ⁶ SIJBEDA, P., *Een Boekien, Waar in Geschreven Sijn, Alle Sprrten van Verwen, Welke Tot Een Gleijbakkerij Nodig Sijn, Te Gebruijken, En de Manier Hoe Men Desselve Moet Perpareren. Enz.*, handwritten notebook, Harlingen: Museum Hannemahuis, 1712 (inv. num 872).
- ⁷ FEIJTEMA, S. *Aenmerkingingen Rakende de Gleibakkerij [1725]*, Transcript, Museum Hannemahuis.
- ⁸ KUNCKEL, J. 'Von dem Hollandischen, oder (so genannten) Barcellanischen, Weissen und bunten Topffer- Glasur- un Mahlerwerck' in *Ars Vitaria Experimentalis, Oder Volkommene Glasmacher-Kunst*, Frankfurt/Leipzig, 1679.
- ⁹ FREESE, A. *Proefkundige Verhandeling van Wit En Gecouleurd Platiel Verglas En Schilderwerk; Benevens Eene Duidelyke Onderrichting van Het Glas-Schilderen*, 's-Gravenhage: H. H. van Drecht, 1774.
- ¹⁰ DIDEROT, D., & J. L. R. D'Alembert, *Encyclopédie ou Dictionnaire raisonné des sciences, des arts et des métiers*, Paris, 28 volumes, 1751 – 1772, volume 6, 1756, 'Fayence' pp. 454 – 460.
- ¹¹ TICHELAAR, P.J. *Bolsward*. Leiden: Primavera Pers, 2001.

¹² De JUSSIEU, A., 6.lI-ell-derot and d'JUSSIIEUIE JUn *Histoire de l'Acadre d Royale des Sciences*,1717: 17: e des Sciencesextracted [from barilla] makes up a considerable part of the trade of the Spanish coast. The foreign merchants prefer it to all the [soda] which one draws from other plantsrom 'La soude quude tire fait une partie considerable et les marchands éarchand la preferent a toutes celles que l'on tire dre dttn plantessnt

¹³ SIJBEDA 1712 p 3-7-9 and 122.

¹⁴ BRILL, R. H. *The Chemical Interpretation of the Texts*, in *Glass and Glassmaking in Ancient Mesopotamia.*, Corning, N. Y. The Corning Museum of Glass, 1970. 105–128

¹⁵ DUNGWORTH, D - *Innovations in the 17th-century glass industry: the introduction of kelp (seaweed) ash in Britain*, in Verrières et leur devenir, Actes du deuxième colloque International de l'association verre & Histoire, Nancy 26 – 28 March 2009

¹⁶ DIDEROT p 1751 and p 456.

¹⁷ BRILL, R., H., *Chemical Analysis of Early Glasses*. Vol. 1 and 2, Corning, New York: Corning Museum of Glass, 1999.

¹⁸ SIJBEDA 1712 p 153 -155.

¹⁹ CAIGER-SMITH, A. *Tin-Glaze Pottery in Europe and the Islamic World: The Tradition of 1000 Years in Maiolica, Faience and Delftware*. London: Faber and Faber, 1973, p 51.

²⁰ CAIGER-SMITH IDEM p 51.

²¹ BRILL IDEM.

²² BASTINAIRE – DAUDENART, F. *L'Art de fabriquer la faïence recouverte d'un émail opaque blanc et coloré*, La Librairie Scientific et Industrielle, De Malher et C^{ie}, Paris, 1828.

²³ FRANCHET, *La Fabricaiton Industrielle des Emaux er Couleurs céramique*, Paris 1911. p 84.

²⁴ RICE, P. *Pottery Analysis: A Sourcebook*. Chicago etc.: Chicago etc., =University of Chicago.

²⁵ CAIGER-SMITH, A. 1973.

²⁶ VAN LOOKEREN CAMPAGNE, K. 'Not too white': an investigation into the influence of the use of calcium carbonate-rich imported marls on 17 - 18th century Dutch tin-glaze tile production. TECHNART 2018 (Non-destructive and Microanalytical Techniques in Art and Cultural Heritage), Bilbao, Spain. Book of Abstracts.

Improving data exploration methods from macro imaging techniques: in situ scanning macro-XRF investigation on a majolica tile tableau

Marco Colombo

*School of Science, University of Bologna, Ravenna, Italy, marco.colombo8@studio.unibo.it
Department of Chemistry, AXES research group, University of Antwerp, Antwerp, Belgium,
marco.colombo@student.uantwerpen.be*

Stijn Legrand

*Department of Chemistry, AXES research group, University of Antwerp, Antwerp, Belgium,
stijn.legrand@uantwerpen.be*

Geert Van der Snickt

*Department of Chemistry, AXES research group, University of Antwerp, Antwerp, Belgium,
geert.vandersnickt@uantwerpen.be*

Koen Janssens

*Department of Chemistry, AXES research group, University of Antwerp, Antwerp, Belgium,
koen.janssens@uantwerpen.be*

SUMMARY: Since the 1980s, when conservation science started to become an internationally recognized discipline within the cultural heritage sector, the analytical characterization of ceramic manufacture processes has been of wide interest. Therefore, in the last decades, numerous research projects were carried out in this field, as the ones of Catapano [1] and Bersani [2].

The application of analytical techniques to the study of majolica artefacts and artworks has led to a considerable progress in the knowledge of its production technology, as remarked by Tite [3]. Furthermore, these techniques allow to distinguish between objects that may have a similar appearance, but that were made using different raw materials. However, to obtain reliable stratigraphic information of majolica objects, invasive techniques are often employed, as in the works of Alaimo [4], Padeletti [5] and Pérez-Arantegui [6].

Instead, in the area of cultural heritage studies there is a special need for in-situ non-destructive and mobile techniques, since often ceramic artefacts and artworks cannot be moved, as Van de Voorde reports [7]. The development and the use of such mobile devices, is therefore fundamental in ceramic conservation science.

For the aforementioned reasons, in this project a state-of-the-art method for non-invasive visualization of (sub)surface layers present in works of art was employed for the first time. The aim was to study ceramic artefacts and artworks, and more specifically: six ceramic tiles of different origins, and an Antwerp majolica tile tableau manufactured in the mid of the 16th century, as suggested by Caignie [8]. Macroscopic X-ray fluorescence scanning (MA-XRF), a technique developed by Alfeld [9] over the last decade for the investigation of historical paintings, was used to:

- 1. determine the characteristic elements of the renaissance majolica production process and the pigments that were used for the colorful motifs present on these majolica tiles;*
- 2. gain new insights on the late 19th century Villeroy & Boch ceramic tiles manufacturing process.*

Furthermore, by using the software package PyMCA developed by Solé [10], and the in-house written software package Datamuncher developed by Alfeld [11], a careful interpretation of the

ensuing elemental images allowed to visualize earlier retouchings in a detailed fashion and to distinguish original tiles from pieces that were introduced during nineteenth and twentieth century restoration campaigns.

These results illustrate the reasons why MA-XRF is well suited for the study of (nearly flat) ceramic artefacts and artworks.

KEY-WORDS: Ceramics, MA-XRF, Non-destructive analysis, Tiles

RESEARCH OBJECTIVES

Within the broad field of ceramics, this project focused on 16th century Antwerp majolica, probably originating from the studio of the famous Antwerp majolica maker Guido Andries (Guido di Savino), one of the Italian craftsmen who brought the majolica technique to Antwerp, transforming the city into an important center for majolica art.

Next to that, were also investigated two industrial tiles probably manufactured at the end of the 19th century by the *Villeroy & Boch* ceramic factory.

In order to chemically characterize these materials, were performed several MA-XRF scans.

The penetrative properties of the X-ray beam, in combination with the element-specificity of the collected fluorescence signals, were used to investigate the four majolica tiles present in the six separately scanned tiles and the Antwerp majolica tile tableau - “Saul’s conversion”, to study the glazing techniques employed, and to document which pigments are present in the various colored areas of the tiles.

In this project we also explore to what extent MA-XRF scanning, conducted prior to a full-scale conservation treatment, can help answering research questions related to authenticity issues. Through elaboration and interpretation of the MA-XRF data, we investigate whether it is possible to objectively make a distinction between authentic and non-authentic tiles and to what extent is feasible to classify the tiles with doubtful authenticity.

SCANNING MA-XRF ON SIX SELECTED CERAMIC TILES OF DIFFERENT ORIGINS

Background

In the fall of 2015 the AXES research group of the University of Antwerp had the opportunity to perform, for the first time, several MA-XRF scans on ceramic tile tableaus. Six tiles of different manufactures belonging to the MAS (Museum Aan de Stroom) “Museum Vleeshuis” collection, Antwerp, Belgium, were asked to be scanned prior to a full-scale conservation treatment of the renowned 16th century Antwerp majolica tableau – “Saul’s conversion”; this is one of the most important masterpieces of the “museum Vleeshuis” collection and was also partially scanned in the 2015 measurement campaign (s. chapter 3).

A photograph of the six tiles is shown in Figure 1. The reason why the conservators asked to perform the MA-XRF scans of the 6 tiles has to be found in the doubtful authenticity of tiles n° 1, n° 2, n° 5 and n° 6.

Thanks to Caignie [8] we know the following about the six tiles:

- a) tile n° 1 and n° 2: industrial tiles, probably made by the *Villeroy & Boch* ceramic factory at the end of the 19th century;
- b) tile n° 3 and n° 4: original tiles of the 16th century Antwerp majolica tableau – “Saul’s conversion”;
- c) tile n° 5 and n° 6: majolica tiles that look similar to the ones of the tile tableau.



Figure 1: Photograph of the six tiles scanned in the 2015 MA-XRF measurement campaign at the MAS (Museum Aan de Stroom) “Museum Vleeshuis” collection, Antwerp, Belgium.

Experimental

The scanner used, is an advanced version of the instrument B described by Alfeld [9]. It consists of a measurement head mounted on a software-controlled X-Y motor stage with an ESP 301 3-Axis Motion Controller (Newport Corporation, Irvine, CA, USA) with a maximum travel range of 57 x 60 cm (h x v). The measurement head consists of a compact 10W Rh anode transmission tube (Moxtek, UT, USA) operated at 45 kV and 200 μ A and a Vortex EX-90 Silicon Drift detector (SDD) with a 50 mm² active area (SII, Northridge, CA, USA) positioned close to the incident X-ray beam. The diameter of the diverging primary beam is reduced by means of a 0.8-mm lead pinhole collimator, yielding a beam size of ca 1.2 mm at the surface of the six majolica tiles. MA-XRF scans were performed by sweeping the measuring head systematically over the tiles 'surface, as in Da Silva [12].

Careful positioning and alignment of the scanner ensured a stable distance of ca.1.5 cm in between the snout of the scanner and the tiles. Alignment was obtained by manually adjusting the distance between the X motor stage and the tile surface while moving the measuring head along the X-axis. To do so, the position of the X-motor was adjusted, while the majolica tiles remained immobile. During the movement, XRF spectra were recorded every 700 μ m (step size) with a dwell time of 350 ms (real time) for each spectrum, using a DXP-XMAP multi-channel analyzer (XIA LLC, Hayward, CA, USA).

Interpretation of the results

Majolica tiles n° 3, n° 4, n° 5 and n° 6

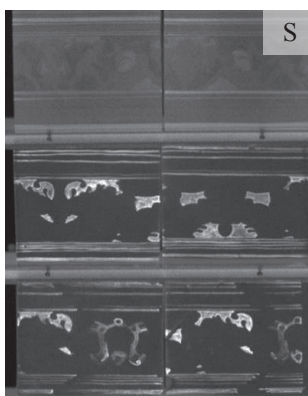
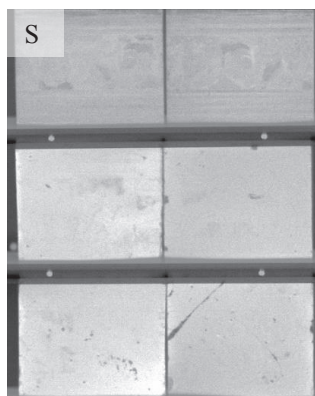
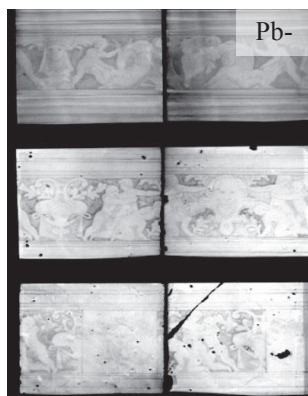
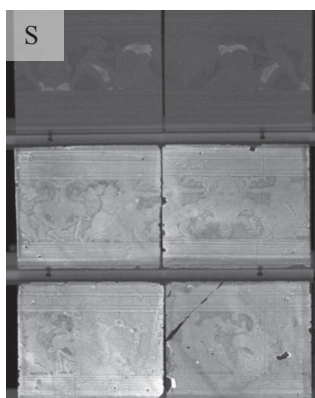
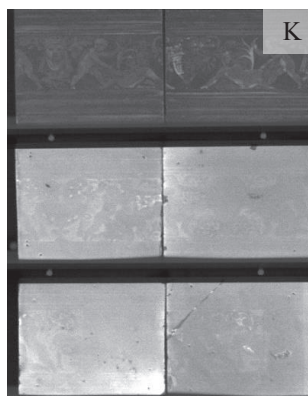
Figure 2 shows the elemental distribution images that characterize the six tiles scanned.

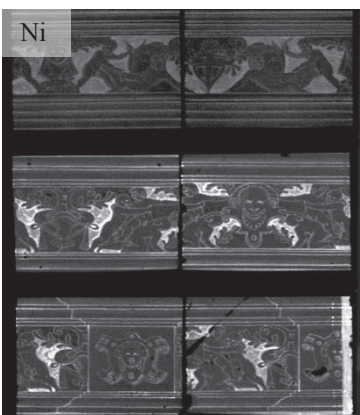
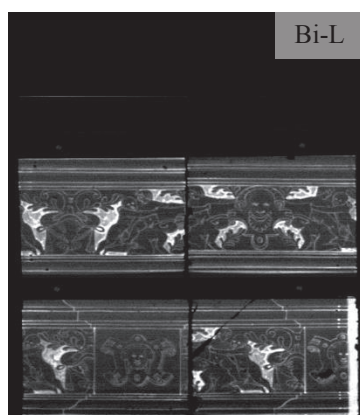
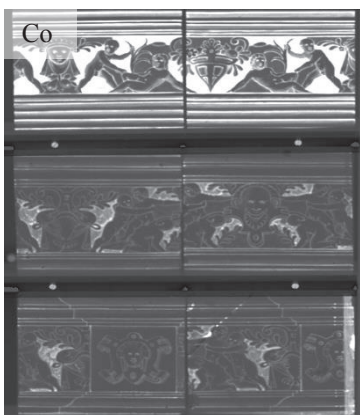
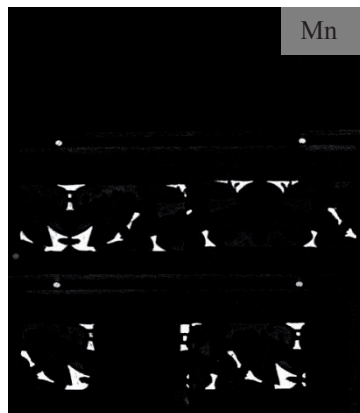
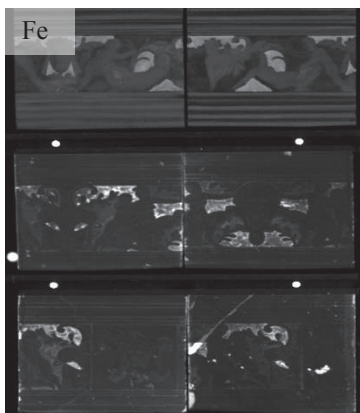
All elemental distribution images presented in this paper are related to K-line transitions, unless differently specified. Furthermore, in all images the minimum and maximum intensity values were selected in order to enhance their readability and highlight the features being discussed.

All elemental distribution images were corrected for dwell time variations by means of the "dwell time AXIL" tool within the "correct" window in the software *Datamuncher*.

The elements visible in the distribution images presented in Figure 2 can be related to the different production stages of these tiles.

As we can objectively see, tiles n° 3, n° 4, n° 5 and n° 6 appear to have similar elemental distribution, suggesting that these tiles were probably manufactured with the same majolica technique and probably in the same period: the 16th century. If we look towards tiles n° 1 and n° 2, their composition and probably method of manufacture are clearly different if compared to the four other tiles, since a different elemental distribution is present.





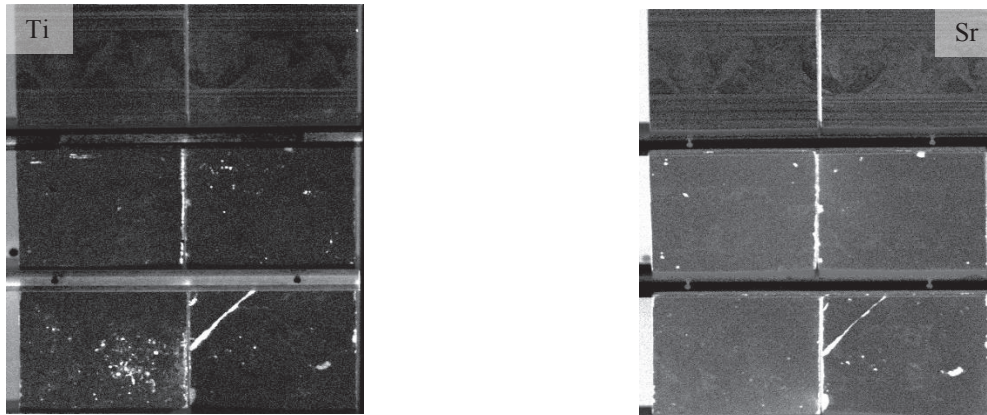


Figure 2: The six tiles scanned. Photograph and elemental distribution images of K, Sn, Pb-L, Si, Sb, Fe, Mn, Co, Bi-L, Ni, As, Ti and Sr. Data processed with in-house written software *Datamuncher*.

If we look at the distribution images of the elements K, Sn, Pb and Si, their presence in the tiles n° 3, n° 4, n° 5 and n° 6, is consistent with the typical glazed ceramics composition until the 19th century, consisting of (a) a ceramic biscuit and (b) a white glaze (Figure 3).

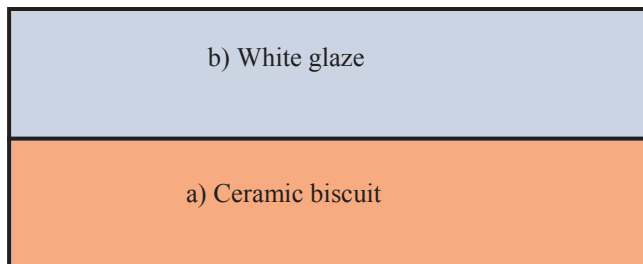


Figure 3: Schematic of layering of typical glazed ceramics composition until the 19th century.

The white glaze contains lead and silicon as primary components, which can be deduced from the relative uniform detection of lead over the tiles in the Pb-L map (local absorption to pigments not calculated). Furthermore, the lead distribution allows us to readily distinguish between original areas (presence of lead; brighter tone), the restored one in correspondence of the oblique line in the tile n° 6 (where lead is not present; darker tone), and the ones where the glaze is missing (where lead is no longer present; darker tone).

In the original Pb based glaze, tin was added to opacify it. In addition, the potassium map looks similar to the tin map, due to the presence of potassium dispersed in the glaze.

A final thin “coperta” of transparent glaze (Pb+Si+K) may have been sprinkled over the surface, as it was addressed by Mimoso [13] in a paper on Flemish tiles.

The blue decorations are characterized by the presence of cobalt, suggesting the use of smalt (PbO-SiO₂-K₂O-CoO + associate elements). Although cobalt was only recognized as a separate chemical element in the 18th century, its use (in the form of compounds or ores) as pigment has been known for thousands of years. Even at low concentration levels, it produces a noticeable

blue tint in an enamel. As reported by Mimoso [14], the concomitant presence of arsenic, nickel, bismuth and iron in the blue decorations is due to the fact that, during the 16th century the blue pigment originated from the cobalt ores of the Erzgebirge, showing a characteristic association of Co, As, Ni and Fe. Eventually it may also contain different amounts of bismuth, Fares reports [15], as in the case under examination, suggesting that the pigment was processed at a relatively low temperature and therefore that the tiles n° 3, 4, 5 and 6 are ancient and of similar chronology. This correlation of elements agrees with the fact that the traditional chromophore used for ceramic pigments with a blue tint is the cobalt ion incorporated into different crystalline structures (silicate, aluminate, stannate, chromite, etc.), as indicated in Orecchio [16].

From the elemental distribution images of antimony and iron in Figure 2, it is clear that they are elements characteristic for both the yellow and orange decorations. This evidence can be associated with the use of Naples Yellow ($\text{Pb}_2\text{Sb}_2\text{O}_7$), and iron oxides. The explanation is consistent with the introduction of the yellow lead antimonate pigment in the majolica palette from the first half of the 15th century onwards, and with the fact that many times it has been found mixed together with different amounts of iron oxides, as it was found in the work of Cartechini [17].

The purplish brown decorations show the presence of manganese, indicating the use of manganese-rich minerals (e.g., MnO_2). Manganese exists in various oxidation states and can incur several colors. The tone of these colors in the decorations can be modified by the kiln atmosphere. In a non-reducing kiln conditions, the color of manganese-containing glass is pink. If present from 5 to 10%, manganese produces shades of purplish brown, as it was found by Karasu [18].

The retouching in correspondence of the oblique line in the tile n°6, shows the presence of titanium and strontium that are likely introduced to obtain the desired pastel shades during the restoration, or as opacifier.

Industrial tiles n° 1 and n° 2

As mentioned at the beginning of this chapter, the distribution of the elements in tiles n°1 and 2 looks singular compared to the majolica tiles n° 3, n° 4, n° 5 and n° 6. This is probably due to their industrial manufacture. As written by Caignie [8] the tiles are likely to have been made by the *Villeroy & Boch* ceramic factory at the end of the 19th century.

In order to gain new insights on the manufacture of the tiles n°1 and 2, the original file from which the elemental distribution images of the six tiles were obtained was “cut” by means of the “cut-off” tool within the “correct” window in the software *Datamuncher*, allowing to obtain the elemental distribution images only for tiles n° 1 and n° 2. Practically speaking, this tool allows to have the intensities of the identified elements only in the area of interest (the one that is cut out), avoiding a misinterpretation due to the fluorescence signals of elements that are more abundant in the surrounding areas. This is particularly useful when dealing with images that give an unusual combination of elements, as in the case under examination.

Figure 4 shows the distribution images of the elements that characterize the tiles n° 1 and n° 2.

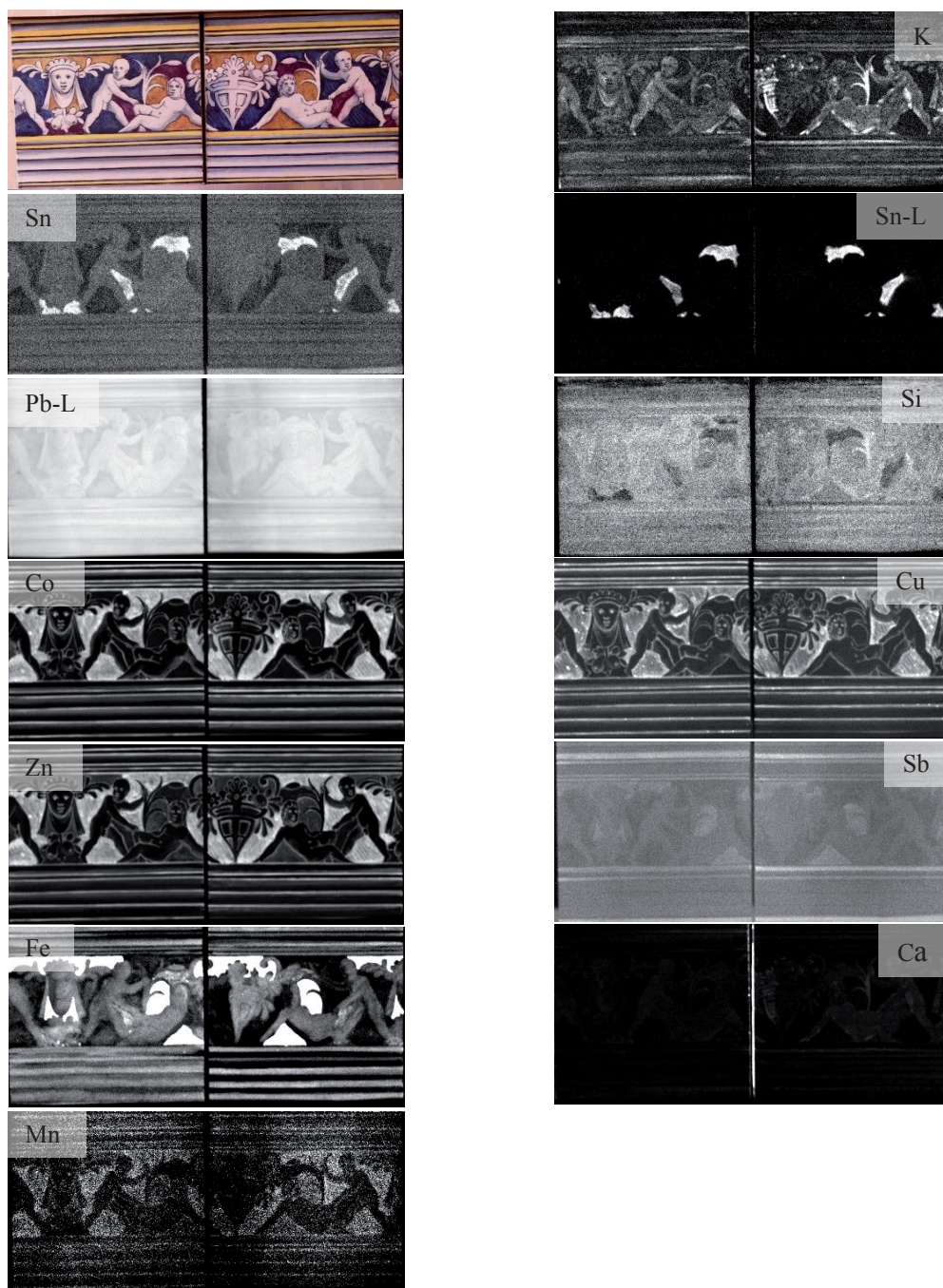


Figure 4: Industrial tiles n° 1 and n° 2. Photograph and elemental distribution images of K, Sn, Sn-L, Pb-L, Si, Co, Cu, Zn, Sb, Fe, Ca and Mn. Data processed with in-house written software *Datamuncher*.

If comparing the distribution images of K, Sn, Ca and Pb in Figure 4 to those of the tiles n°3, 4, 5 and 6 (Figure 2), these elements seem to have been barely used during the different production stages, confirming the more recent manufacture of tiles n°1 and 2.

The industrial tiles have a possible layered structure of two layers, consisting of (a) a ceramic biscuit and (b) a white glaze (Figure 5).

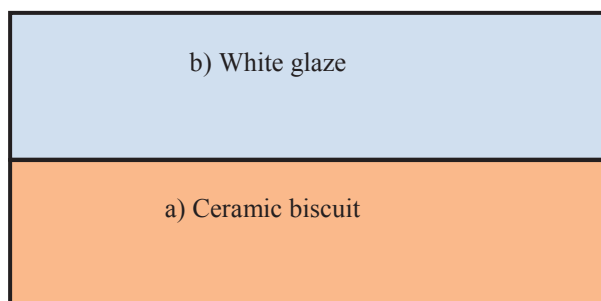


Figure 5: Schematic of layering of industrial tiles n°1 and 2.

The blue decorations are characterized by the presence of cobalt, suggesting the use of a cobalt based pigment (CoO + associate elements). From the 19th century onwards, according to Schalm [19] pure industrial produced cobalt-oxide (CoO) was used. This is in correlation with the fact that in Modum, Norway, a plant started to process the ore under the royal patronage in 1776 and by the 1820s it supplied 80% of all the world needs in cobalt pigment, as reported by Mimoso [14]. Copper is also likely to be present in the blue decorations as can be deduced from its distribution image. This is consistent with the use, in some recipes, of calcinated copper (CuO). The concomitant presence of iron is due to the fact that the cobalt pigments were most likely obtained from cobalt-rich minerals which are often coupled with other metal oxides, such as Fe. The blue decorations also show the presence of zinc together with cobalt and copper, as from the elemental distribution images is possible to see that the painter went twice over some boundary areas which are “whiter” in the maps of all three elements.

The orange and yellow areas seem to be correlated with the distribution images of antimony and iron, suggesting the possible presence of Naples Yellow ($\text{Pb}_2\text{Sb}_2\text{O}_7$), and iron oxides (Fe_2O_3 , Fe_3O_4 etc.). However, this is not as straightforward to say as it was for tiles n° 3, n° 4, n° 5 and n° 6. As a matter of fact the Fe and Sb distribution images of tiles n° 1 and n° 2 show a high noise/artefact level (Figure 4). A data exploration method such as the ROI imaging tool in PyMCA is therefore needed in order to obtain new scientific clues on the presence of the elements aforementioned in the orange and yellow coloured areas.

In Figure 6 a photograph of tiles n° 1 and n° 2 is shown, together with the points (A) and (B) from where the local sum spectra of the orange and yellow rich areas were obtained respectively. Both spectra show the presence of Pb, Sb and Fe, confirming the possible use of Naples Yellow ($\text{Pb}_2\text{Sb}_2\text{O}_7$), and iron oxides. However, the Sb signal related to the orange rich area is clearly less intense if compared to the Sb signal in the yellow rich area. This is an indication that Sb was barely mixed with Fe to create the orange tonality, instead we can assume that it was used to create the intense yellow color.

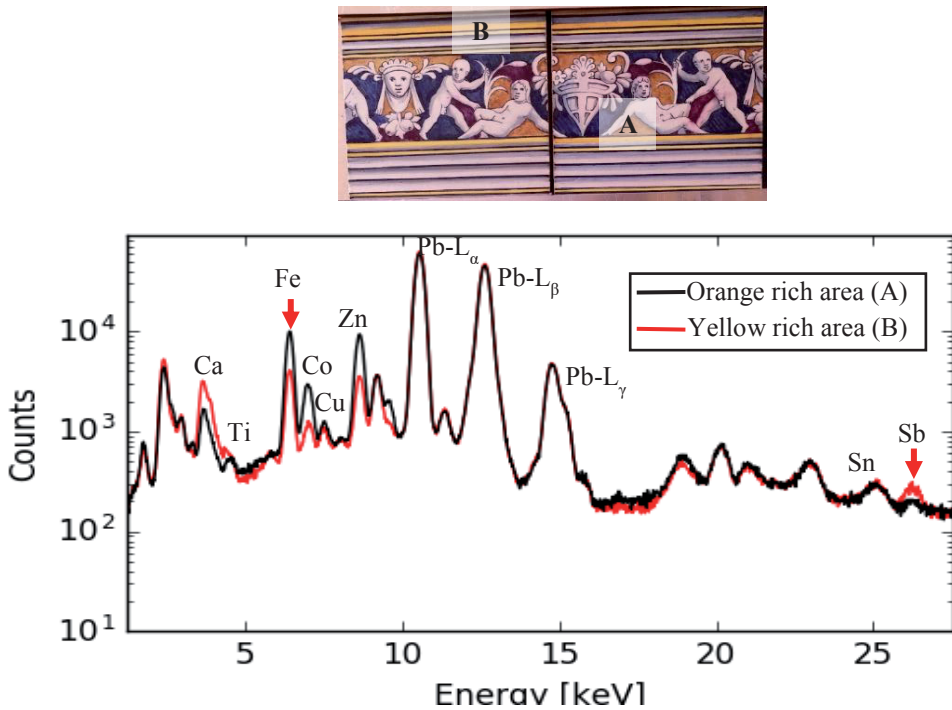


Figure 6: Photograph of tiles n° 1 and n° 2 with point (A) - orange rich area, and point (B) - yellow rich area. The local sum spectra in points (A) and (B) shows that the Sb signal is clearly less intense in the spectrum representing the orange rich area (A), indicating that it is likely to have been barely used in the mixture.

This can be confirmed by the Fe/Sb scatter plot in Figure 7, where it is possible to clearly distinguish the pixels in which Fe is present almost without Sb, and pixels where Fe is present together with Sb and associate them with the orange and yellow areas respectively; the distribution of these elements can be visualized by colouring the Co distribution image in Figure 7 accordingly.

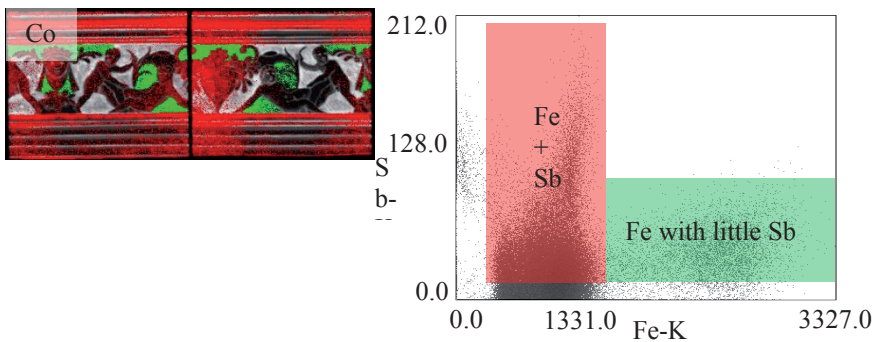


Figure 7: Co map colored based on the Fe/Sb ratio to visualize the presence of Naples Yellow and iron oxides in the yellow and orange decorations. The (negative) values before 0 in the X, Y axes of the Fe/Sb graph are not shown since no relevant information were found to be there.

In the purplish brown decorations, we expect the presence of manganese in the form of oxide. However, from its elemental distribution image we can evince that manganese is hardly present in the purplish brown decorations. On the other hand, these areas show the presence of iron that could have been used as oxide in the mixture (Fe_2O_3 , Fe_3O_4 etc.). Tin is also present in the brownish spots, as confirmed by the Sn-L map. It could have been used either to lighten the color or, more likely, to contain the color so that it would not diffuse out of the painted area.

3. CASE STUDY: SCANNING MA-XRF ON A MAJOLICA TILE TABLEAU DEPICTING SAUL'S CONVERSION

3.1 Background

During the 2015 MA-XRF measurement campaign at the MAS museum, Antwerp, Belgium, in addition to the scans of the six tiles discussed in chapter 2, the conservators asked the AXES researchers to perform several scans of the renowned 16th century Antwerp majolica tile tableau – “Saul’s conversion”.

During the last centuries, the majolica tile tableau, due to its poor conservation state, underwent different conservation treatments. Some tiles were missing, so the conservators chose to replace them with ones made by synthetic materials. Furthermore, the conservators implemented various other conservation processes aimed to restore the original appearance of the tile tableau, as reported in Caignie [8].

Since the tableau was to be restored in 2016 prior to an international exhibition, a chemical investigation was thought essential in order to better understand what was done in the past and as documentation for the planned treatment.

This multicolored tableau (Figure 8) consists of 98 glazed tiles and was made following Italian techniques. The tableau is dated 1547 and is believed to originate from the studio of the famous Antwerp majolica maker Guido Andries (Guido di Savino), one of the Italian craftsmen who brought the majolica technique to Antwerp, transforming the city into an important center for majolica art.

The processing and the interpretation of the data coming from the MA-XRF scans that were performed on the majolica tile tableau, aimed to identify the most relevant differences between the pigments used in the tableau and the pigments used in the majolica tiles n° 3, n° 4, n° 5 and n° 6 discussed in chapter 2; as well as to compare their chemical makeup in order to identify pigments that are not present in the majolica tiles n° 3, n° 4, n° 5 and n° 6, and to make an overall distinction between the original and the restored areas in the tableau, confirming the presence of materials and pigments that are not present in the authentic areas.

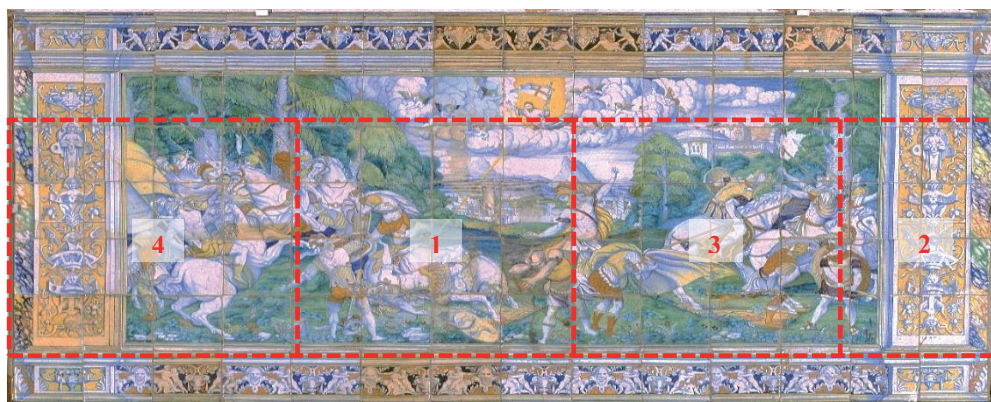


Figure 8: Photograph of the Tile tableau of “Saul’s Conversion”, Museum aan de Stroom – MAS | collectie Vleeshuis, Antwerp (Belgium). The red shapes indicate the four scanned areas (see below).

3.2 Experimental

The MA-XRF scanner and its setup parameters for the measurements that were performed on the majolica tile tableau, were the same to the ones used to scan the six tiles (s. chapter 2.2).

The majolica tile tableau was not scanned in its entirety; instead four meaningful sections were chosen to be scanned one at a time in a total scanning time of 9 days.

Interpretation of the results

The presentation of the results of the MA-XRF scans performed on the majolica tiles n°3, 4, 5 and 6 (s. chapter 2.3.1), allowed to speak about the typical glazed ceramics composition until the 19th century and some of the pigments employed for the decorations at that time.

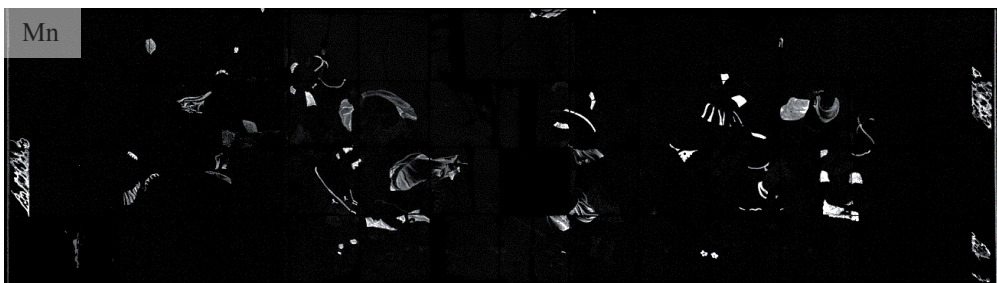
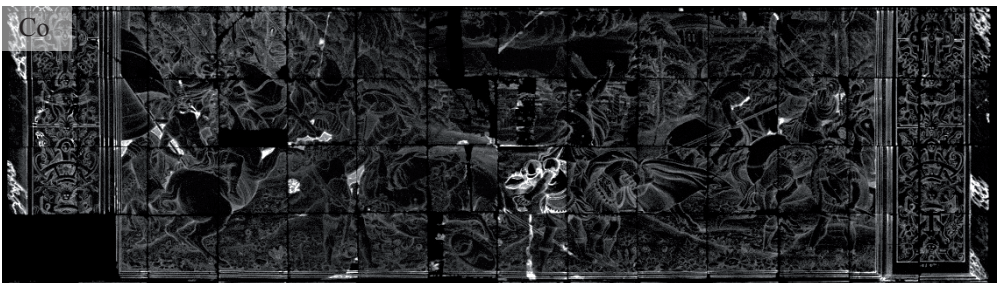
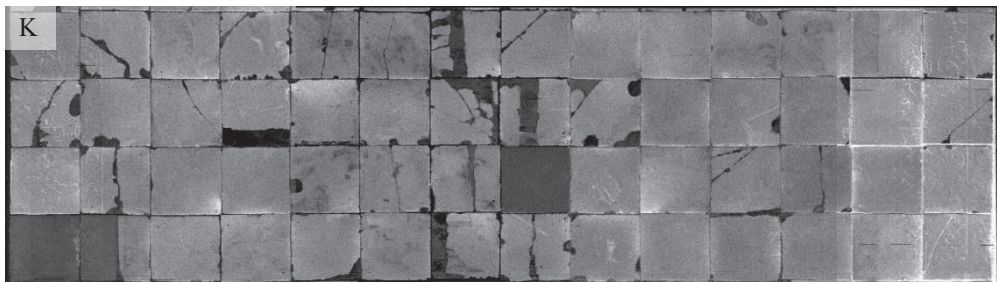
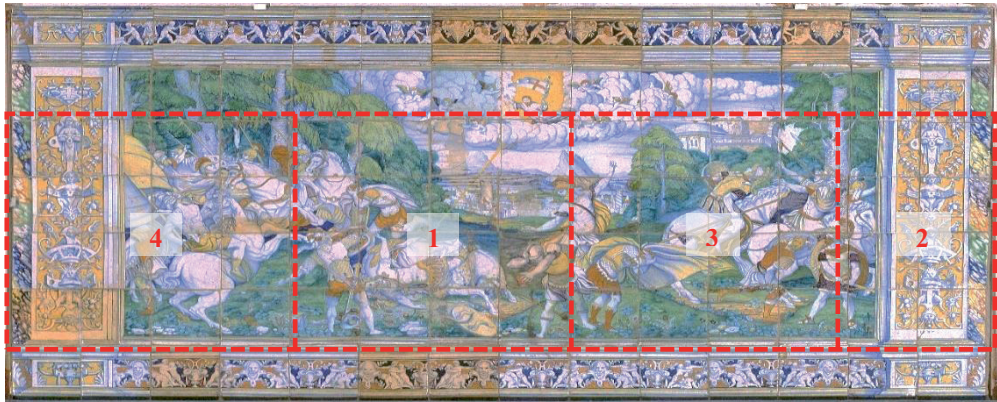
Therefore, the presentation of the outcomes of the MA-XRF scans performed on the majolica tile tableau - “Saul’s conversion”, aims to underline what follows:

- any different raw material employed for pigments present either in the majolica tile tableau and the tiles n°3, 4, 5 and 6;
- any pigment that is present in the majolica tile tableau and that is not present in the tiles n°3, 4, 5 and 6;
- the different elemental composition of the non-authentic areas in the majolica tile tableau due to earlier retouchings and pieces that were introduced during nineteenth and twentieth century restoration campaigns;
- the overall presence on the tableau of the elements that characterize the non-authentic areas.

Original areas

The elemental distribution images of the four scanned areas were corrected for dwell time variations and stitched together by means of the in-house written software *Datamuncher*, to obtain 2790×815 pixel images.

Figure 9 shows the stitched distribution images of the elements K, Co, Mn, Fe and Cu.



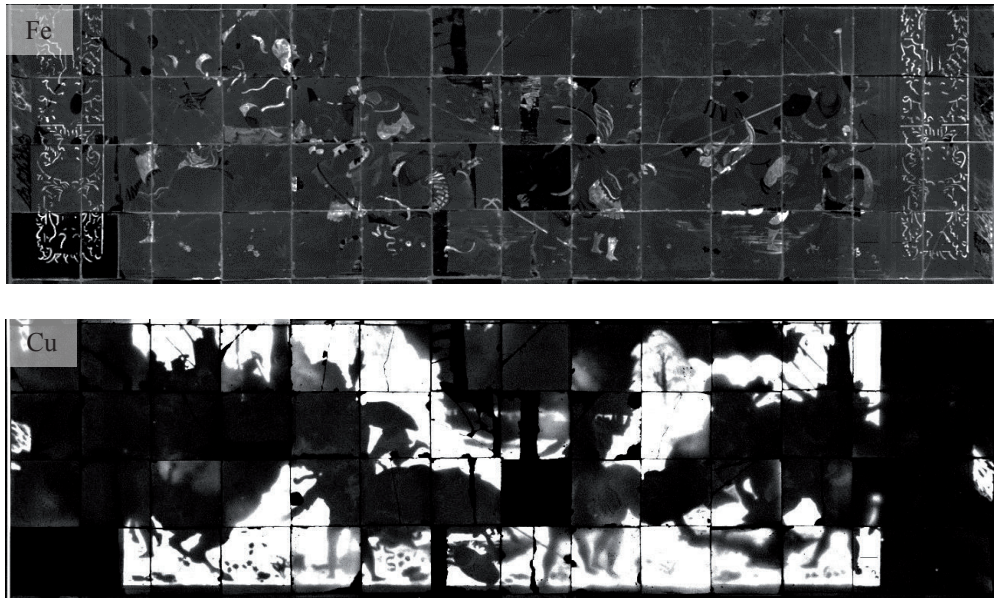


Figure 9: Tile tableau of “Saul’s Conversion”, Museum aan de Stroom – MAS | Collectie Vleeshuis, Antwerp (Belgium). Photograph and elemental distribution images of K, Co, Mn, Fe and Cu. Data processed with in-house written software *Datamuncher*. The red shapes in the photograph indicate the four scanned areas.

If we carefully look towards the distribution images presented, the presence of Fe in the blue decorations, already associated to the smalt ($\text{Si}+\text{Pb}+\text{K}+\text{Co}$ + associate elements), agrees with the fact that smalt was most likely obtained from cobalt-rich minerals and for this reason is often coupled with other metal oxides, such as Fe.

Black motifs are recognized and associated with mixtures of iron (Fe_2O_3 , Fe_3O_4 etc.), cobalt (CoO) and manganese (e.g. MnO_2) oxides, as suggested by Coentro [20].

The green decorations appear to have been prepared on the basis of a copper-based pigment, for example copper oxide.

Earlier retouchings

In order to gain further knowledge on the elements that characterize the earlier retouchings in the tableau, a sub-area labelled as A, was investigated (Figure 10).

The most relevant elemental distribution images of the area A are discussed below.

Although the elements are often correlated to colors that are not easily discernible due to the limited resolution of the detail photograph, it was possible to explore the complex mixtures used during past restoration treatments.

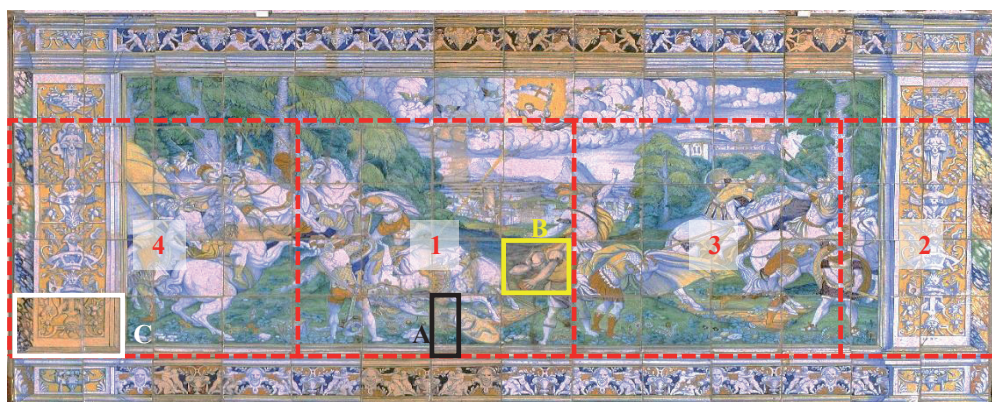


Figure 10: Photograph of the Tile tableau of “Saul’s Conversion”, Museum aan de Stroom – MAS | collectie Vleeshuis, Antwerp (Belgium). The red shapes indicate the four scanned areas, instead the black, yellow and white rectangles indicate the areas A, B, C being discussed.

Sub-area A

Figure 11 shows the most relevant distribution images for the sub-area A marked with a black rectangle in Figure 10.

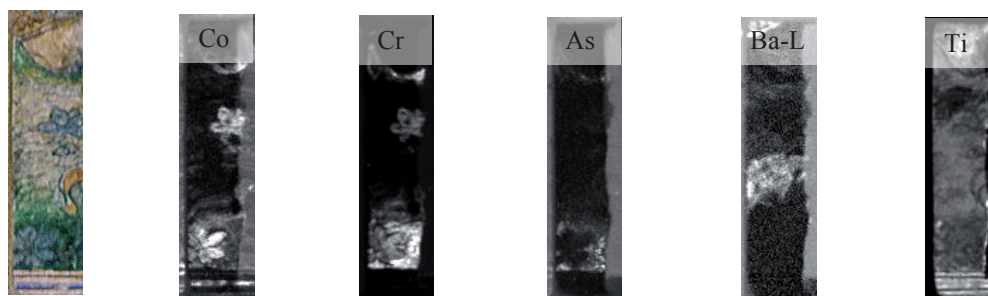


Figure 11: Detail photograph and corresponding elemental distribution images of Co, Cr, As, Ba-L, and Ti of the area (A) indicated in Figure 10 marked with a black rectangle. Data processed with in-house written software *Datamuncher*.

This area was chosen because of its singular combination of elements.

The elemental distribution map of chromium shows its correlation to the green color, suggesting the possible usage of green chromium oxide (Cr_2O_3). This was first synthesized in the 19th century and therefore the material in a chromium green area should be of recent date.

The presence of cobalt mainly in the two blue flowers suggests the use of a cobalt rich pigment with arsenic found as an impurity.

Titanium dioxide (TiO_2) is likely to have been used to obtain the desired pastel shades during the restorations, or as opacifier. The deliberate use of TiO_2 indicates a decoration from at least the 20th century.

Barium, as suggested by Orecchio [16], may have been used to obtain the desired hue during the retouching phase (e.g. *blanc fixe* aka permanent white, BaSO_4). The presence of barium confirms the hypothesized dating (20th century) for the retouchings present in sub-area A.

Later additions

During the restoration treatments carried out by KIK-IRPA (Royal Institute for Cultural Heritage, Brussels, Belgium) between 1960-1965, due to the poor conservation state, Caignie [8] reports that some of the original tiles of the tableau were replaced by polyester replicas.

In order to gain further knowledge on the elements that characterize the replicas present in the tableau, two different sub-areas labelled as B and C, were investigated (Figure 10).

The most relevant elemental distribution images of areas B and C are discussed below.

Since the tiles in the areas B and C are polyester replicas, their elemental composition significantly differs from that of the original tiles. Furthermore, the replicas are discolored due to aging and probably UV light. Discerning these tiles is therefore relatively easily (see Figure 9) and the contrast in the elemental distribution images presented below highlights this.

Sub-area B

Figure 12 shows the distribution images of Co, Fe, Cr and Ni for the sub-area B marked with a yellow rectangle in Figure 10.

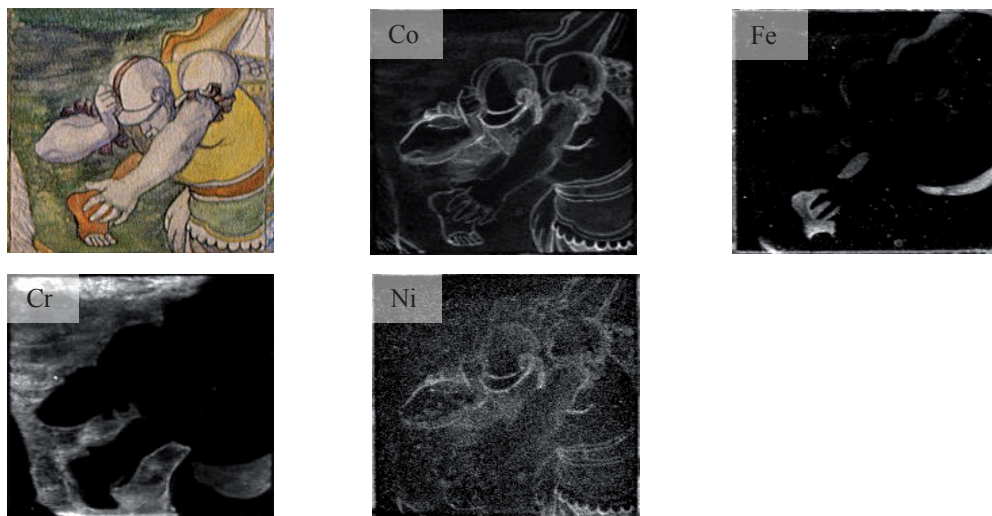


Figure 12: Detail photograph and corresponding elemental distribution images of Co, Fe, Cr and Ni of the area (B) indicated in Figure 10 marked with a yellow rectangle. Data processed with in-house written software *Datamuncher*.

The cobalt distribution map suggests the presence of a blue based pigment with nickel found as an associate element.

The orange decorations present in the belt of the soldier, in the foot and leg on the back of the soldier and in the vest on the upper part of the soldier, are likely to be correlated with the use of mixtures containing different amounts of iron oxides (Fe_2O_3 , Fe_3O_4 etc.).

The green decoration presents in the background of the scene is well correlated to the distribution map of chromium suggesting the possible usage of green chromium oxide (Cr_2O_3).

Sub-area C

Figure 13 shows the most relevant distribution maps for the sub-area C marked with a white rectangle in Figure 10.

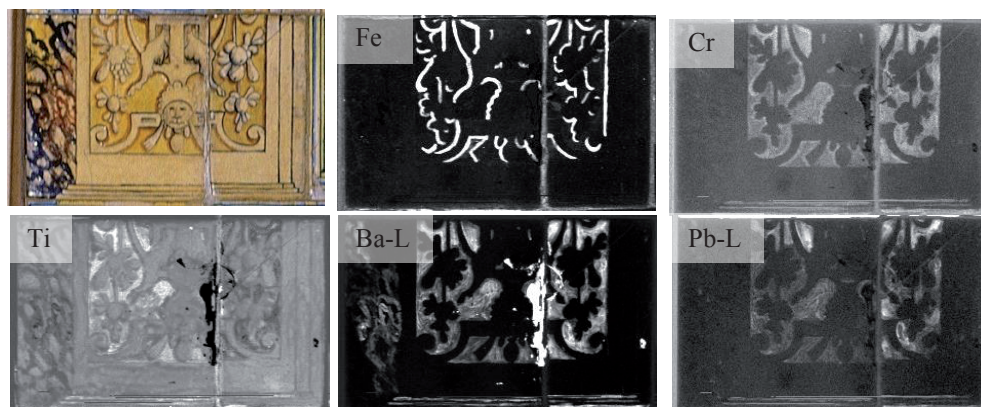


Figure 13: Detail photograph and corresponding elemental distribution images of Fe, Cr, Ti, Ba-L and Pb-L of the area (C) indicated in Figure 10 marked with a white rectangle. Data processed with in-house written software *Datamuncher*.

Titanium dioxide (TiO_2) appears to have been used to obtain the desired pastel shades during the restorations, or as opacifier. If we carefully look at the iron elemental distribution image, the presence of Fe is evident in the orange contours of the white motifs, probably present in the form of iron oxides (Fe_2O_3 , Fe_3O_4 etc.). In order to imitate the orange pattern of the authentic tiles, to some extent similar raw materials were employed.

However, also pigments clearly not present in the authentic tiles were employed. For example, chromium is present in the yellow pattern together with lead, strontium and barium suggesting the use of Chrome yellow (PbCrO_4), Strontium yellow (SrCrO_4) and Barium Chromate (BaCrO_4).

CONCLUSIONS

This work proposed a reliable scientific methodology to characterize the Antwerp 16th century majolica production and two 19th century tiles probably made at the *Villeroy & Boch* ceramic factory. The employment of MA-XRF, with the advantage of its mobility and non-destructiveness provided elemental identification. MA-XRF scanning is a novelty in the field of scientific investigations carried out on ceramic artefacts and artworks. As a matter of fact, chemical elements present in these type of cultural heritage objects are most of the times determined locally and invasively. In the first case by investigating a number of locations in a non-destructive manner with a portable XRF instrument, in the second case by sampling the object and preparing a cross section through its stratigraphy for investigation with SEM-EDX.

MA-XRF allows to gain insights on the distribution of an element over the entire surface of a ceramic artwork on the one hand, and for a faster investigation without the need to transport the ceramic artwork from the museum to a research facility on the other. The results of this research project are also extremely important in conservation–restoration ceramic processes, providing important knowledge to conservators and restorers for the use of compatible and adequate

materials in future interventions. In addition, this work emphasizes the possibility to distinguishing the major features of the *Villeroy & Boch* ceramic production, poorly mentioned due to scarcely-existing information. The scientific investigation was also able to highlight similarities and differences within the composition of the investigated artefacts and enables a verification of the hypotheses about their attribution made on art-historical bases. MA-XRF has two fundamental limitations: it only offers elemental, not molecular information and contrast and self-absorption effects can render the detection of light elements in covered layers challenging. Furthermore, the elemental distribution images obtained with MA-XRF are 2-dimensional projections with only limited depth information. These limitations can be overcome by combining MA-XRF with complementary techniques. This is particularly important since only a multi-technique approach can give a complete description of complex materials such as the industrial ceramic tiles analyzed.

For all these reasons we foresee the application of MA-XRF in future projects regarding high-profile ceramic objects, especially when a non-contact and non-invasive diagnostic technique is needed.

BIBLIOGRAPHY

- ¹ CATAPANO, I., AFFINITO, A., GUERRIERO, L., BISCEGLIA, B., SOLDOVIERI, F. - *Majolica imaging with THz waves: preliminary results*. Applied Physics A, 2016, 122:533.
- ² BERSANI, D., LOTTICI, P. P., VIRGENTI, S., SODO, A., MALVESTUTO, G., BOTTI, A., SALVIOLI-MARIANI, E., TRIBAUDINO, M., OSPITALI, F., CATARSI, M. - *Multi-technique investigation of archaeological pottery from Parma (Italy)*. Raman Spectroscopy, 41, 2010, 1556-1561.
- ³ TITE, Michael - *The production technology of Italian maiolica: a reassessment*. Archaeological Science, 36, 2009, 2065-2080.
- ⁴ ALAIMO, R., BULTRINI, G., FRAGALÀ, I., GIARRUSSO, R., ILIOPOULOS, I., MONTANA, G. - *Archaeometry of Sicilian glazed pottery*. Applied Physics A, 79, 2004, 221-227.
- ⁵ PADELETTI, G., FERMO, P. - *Italian Renaissance and Hispano-Moresque lustre-decorated majolicas: imitation cases of Hispano-Moresque style in central Italy*. Applied Physics A, 77, 2003, 125-133.
- ⁶ PÉREZ-ARANTEGUI, J., MONTULL, B., RESANO, M., ORTEGA, M. J. - *Materials and technological evolution of ancient cobalt-blue-decorated ceramics: Pigments and work patterns in tin-glazed objects from Aragon (Spain) from the 15th to the 18th century AD*. European Ceramic Society, 29, 2009, 2499-2509.
- ⁷ VAN DE VOORDE, L., VANDEVIJVERE, M., VEKEMANS, B., VAN PEVENAGE, J., CAEN, J., VANDENABEELE, P., VAN ESPEN, P., VINCZE, L. - *Study of a unique 16th century Antwerp majolica floor in the Rameyenhof castle's chapel by means of X-ray fluorescence and portable Raman analytical instrumentation*. Spectrochimica Acta Part B, 102, 2014, 28-35.
- ⁸ CAIGNIE, Frans - *Majolicategels in het MAS | collectie Vleeshuis*. Version 2. Studierapport, Antwerp, April 2015.
- ⁹ ALFELD, M., JANSSENS, K., DIK, J., DE NOLF, W., VAN DER SNICKT, G. - *Optimization of mobile scanning macro-XRF systems for the in-situ investigation of historical paintings*. Analytical Atomic Spectrometry, 26, 2011, 899-909.

- ¹⁰ SOLÉ, V. A., PAPILLON, E., COTTE, M., WALTER, P., SUSINI, J. - *A multiplatform code for the analysis of energy-dispersive X-ray fluorescence spectra*. Spectrochimica Acta Part B, 62, 2007, 63-68.
- ¹¹ ALFELD, M., JANSSENS, K. - *Strategies for processing mega-pixel X-ray fluorescence hyperspectral data: a case study on a version of Caravaggio's painting Supper at Emmaus*. Analytical Atomic Spectrometry, 30, 2015, 777-789.
- ¹² DA SILVA, T. A., LEGRAND, S., VAN DER SNICKT, G., FEATHERSTONE, R., JANSSENS, K., BOTTINELLI, G. - *MA- XRF imaging on René Magritte's La condition humaine: insights into the artist's palette and technique and the discovery of a third quarter of La pose enchantée*. Heritage Science, 5, 2017, 37.
- ¹³ MIMOSO, J. M., SANTOS, S. A., MILAGRE, M. I., RODRIGUES, C. D., MORAIS, P. S., ESTEVES, L., PAIS, A. N. - *Analytical study of tiles of presumed Flemish origin from the Palace of the Dukes of Braganza in Vila Viçosa*. In from Flanders. The azulejos commissioned by D. Teodósio I, 5th Duke of Braganza (c. 1510-1563), pp. 62-72 (bilingual Portuguese/English) Museu Nacional do Azulejo, Lisboa, 2012.
- ¹⁴ MIMOSO, João Manuel - *Origin, early history and technology of the blue pigment in azulejos*. In Proc. of the International Conference on Glazed Ceramics in Architectural Heritage, Delgado, R. J., Mimoso, J. M., eds. Laboratório Nacional de Engenharia Civil, Lisbon, Portugal, 2015, pp. 357-375.
- ¹⁵ FARES, Marzia - *The blue in portuguese historical azulejos*. MSc dissertation, University of Bologna, Italy, 2012.
- ¹⁶ ORECCHIO, Santino - *Microanalytical characterization of decorations in handmade ancient floor tiles using inductively coupled plasma optical emission spectrometry (ICP-OES)*. Microchemical Journal, 108, 2013, 137-150.
- ¹⁷ CARTECHINI, L., ROSI, F., MILIANI, C., D'ACAPITO, F., BRUNETTI, G. B., SGAMELLOTTI, A. - *Modified Naples yellow in Renaissance majolica: study of Pb-Sb-Zn and Pb-Sb-Fe ternary pyroantimonates by X-ray absorption spectroscopy*. Analytical Atomic Spectrometry, 26, 2011, 2500.
- ¹⁸ KARASU, B., TURAN, S. - *Effects of cobalt, copper, manganese and titanium oxide additions on the microstructures of zinc containing soft porcelain glazes*. European Ceramic Society, 22, 2002, 1447-1455.
- ¹⁹ SCHALM, O., VAN DER LINDEN, V., FREDERICKX, P., LUYTEN, S., VAN DER SNICKT, G., CAEN, J., SCHRYVERS, D., JANSSENS, K., CORNELIS, E., VAN DYCK, D., SCHREINER, M. - *Enamels in stained glass windows: Preparation, chemical composition, microstructure and causes of deterioration*. Spectrochimica Acta Part B, 64, 2009, 812-820.
- ²⁰ COENTRO, S., MIMOSO, J. M., LIMA, M. A., SANTOS, S. A., PAIS, A. N., MURALHA, F. S. V. - *Multi-analytical identification of pigments and pigment mixtures used in 17th century Portuguese azulejos*. European Ceramic Society, 32, 2012, 37-48.

Mortars for the reattachment of old tiles: characteristics needed for preservation of azulejos claddings

Maria do Rosário Veiga

Laboratório Nacional de Engenharia Civil (LNEC), Lisbon, Portugal, rveiga@lnec.pt

SUMMARY: Azulejos used as claddings for external or internal walls are usually attached to the masonry with mortar. While nowadays adhesive mortars are chosen for that purpose, in older times, namely until the middle of the 20th century, traditional lime mortars were used.

One of the main causes of decay of the old azulejo claddings is the degradation of mortars, especially due to the repeated action of water and the attack of soluble salts.

In those cases, the preservation of azulejos requires the reattachment with an appropriate mortar, compatible with the substrate and with the old tile, but also effective and durable enough.

Which kind of mortar should be selected? If high adhesion is specified, the risk is to use a very stiff mortar with low water vapour permeability. Moreover, very high adhesion also promotes an irreversible intervention. On the opposite, a mortar of moderate mechanical and hygric (water absorption and water vapour permeability) characteristics, closer to the old solutions, may be thought to present low durability and high probability of detachment.

In the present article the selection of the mortar to be used for the reattachment of old azulejos will be analysed, taking into account the knowledge about mortars traditionally used for that purpose, the characteristics of the mixes that should be used nowadays considering the main requirements of compatibility and performance.

KEY-WORDS: Azulejos cladding; reattachment of azulejos; setting mortar; adhesion; compatibility requirements.

INTRODUCTION

Azulejos (glazed ceramic tiles) have been used for wall claddings in Portugal at least from the 16th century until present. Until the 19th century they were used mainly in important constructions and as decorative elements in interior wall surfaces. The industrialization of their manufacture, which started in the 19th century [1,2,3], allowed cost reduction and democratized their use in a broader set of building types, including simple housing buildings, and permitted application also as an external façade cladding, with both protective and aesthetic functions (Figure 1). They were bonded with air lime mortars.

Although *azulejos* claddings have proved good durability, a large number of façades with glazed tiles of the 19th century is now in need of refurbishment and the main damage is often the detachment of tiles, due to degradation of the old setting mortars, suffering loss of cohesion or loss of adhesion, usually due to moisture and soluble salts attack [4] (Figures 2 and 3). Hence, for maintenance, the reattachment of old tiles using newly prepared mortars is often needed.

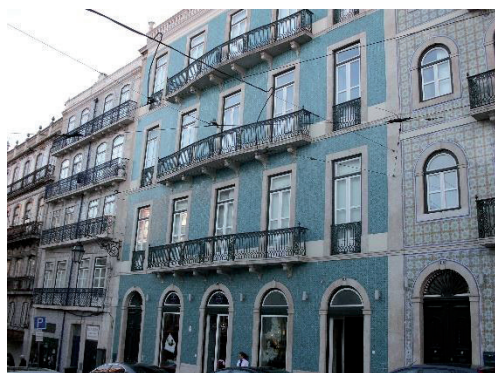


Figure 1: Housing buildings of the period 19th – 20th century with *azulejos* cladding façades (Lisbon, Portugal)



Figure 2: *Azulejos* cladding in a housing building façade with degradation due to loss of cohesion of bonding mortar (Porto, Portugal)

Along the years the manufacturing processes of tiles evolved and the industrialized glazed tiles manufactured nowadays have rather different characteristics, when compared with the 19th century semi-industrialized ones, from the point of view of their microstructure as well as their decorative patterns [5]. Experimental work developed about this subject [1,6] show that the old *azulejos* (late 19th century) tested have higher porosity (aprox. 40-50%) and a narrower range of pores dimensions (aprox. 0.2-1 micron) with maximum concentration in smaller pore size (aprox. 5 micron), by comparison with the modern ones, the most common presenting: aprox. 30-40% porosity; range of pores dimensions aprox. 0.3-4 micron; maximum concentration in aprox. 0.7 micron. Hence, these historic *azulejos* have in general higher water absorption and generally higher capillary coefficient than the modern ones [7]. The bond between lime mortars and porous substrates is mainly physical, produced by the penetration of the fine particles of mortar, dispersed in water, into the porous structures. The connection is developed by the hardening of the binder inside the substrate [8,9], in this case inside the pores of the ceramic body of the tile.

Considering also the differences between old and new walls and their behavior [10], it is clear that the use of modern adhesives specifically developed for the bonding of contemporary tiles cladding is not suitable for the reattachment of the old ones, due to incompatibility both with the old substrates and the ancient *azulejos* considering mechanical characteristics (too stiff), hygric characteristics (low water vapour permeability) and chemical characteristics (high salts content).

When conservation actions are planned, it is important to analyze the behavior of the wall and of the whole building instead of just the connection between tile and masonry. The whole system masonry-setting mortar-*azulejo* must be considered, and the interaction of this system with the environment and with the building in service should be taken into account. This approach will ensure a better preservation of the old *azulejos* and a higher durability of the wall and of the building itself. Additionally, the focus must be made on the conservation of the *azulejos*, which have a relevant cultural value and must be protected from damage as much as possible, while the newly prepared setting mortar may be replaced quite easily.

OLD SETTING MORTARS FOR AZULEJOS CLADDINGS

Reattachment mortars are relevant components of the cladding system, although they are invisible for systems in good conservation conditions. In fact:

- they connect the elements of the system: masonry and tiles, hence they have a key role in the system durability: detachment means damage or even loss of the tile;
- they control salts and of stresses transmitted to tiles;
- they have a significant impact on the performance of the wall: water behaviour, deformability and stress distribution.
- they can interfere with several functions of the cladding, including aesthetics: alters (sometimes subtly) the whole image of the wall / building.

Research on old *azulejos* setting mortars in Portugal, in the large period between the 16th century and the middle of the 20th century, both in internal and external walls applications, is still quite restrict, but the data collected until now evidence the following characteristics [11, 12, 13, 14, 15, 16, 17, 18, 19, 20, 5]:

Composition: the main binders found are calcitic air lime, or, in some cases (namely in some Coimbra case studies), dolomitic lime; aggregates are usually siliceous sand, sometimes with a variable proportion of clay; the very common idea that clayish sand (*saibro*) was always used in the best preserved case studies was not confirmed; clay minerals have been found (illite and caulinite) but in the cases with best state of conservation (and in general in the most noble buildings) they were inexistent and substituted by siliceous filler or found in moderate quantities. Figures 4 and 5 illustrate cases of two Palaces with mortars with no visible traces of clay and presenting rather good cohesion, even if loss of adhesion to the tiles occurred, and Figure 6 shows a simpler housing building with a visible proportion of clay in the mix presenting loss of cohesion; lime: aggregate ratios are very diversified, mainly between 1:2 and 1:6 (in weight).

Mechanical characteristics: Compressive strength mainly between 0.5 and 3.5 MPa.

Hygric characteristics: Capillarity coefficient between 1 and 3 kg/m².min^{1/2}; Open porosity between 25 and 30 %.



Figure 3: *Azulejos* cladding of interior wall panel with degradation (loss of cohesion) of bonding mortars due to moisture (Church).



Figure 4: Bonding air lime mortar of interior wall panel without visible traces of clay (Palace).



Figure 5: Interior wall *azulejo* panel of a palace with bonding air lime mortar without visible traces of clay

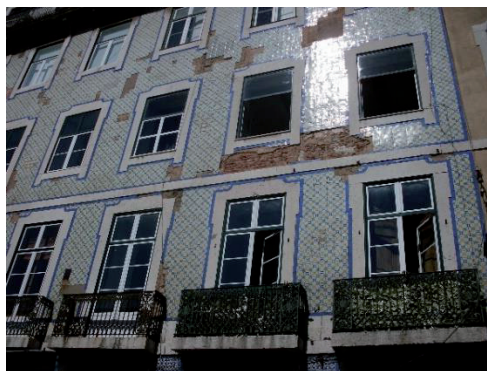


Figure 6: Housing building façade with *azulejos* cladding with deteriorated bonding mortar of lime and sand plus clay

A chronological pattern was not found for those setting mortars. On the other hand, they show differentiation in composition from region to region, surely reflecting different local raw materials and different application traditional techniques. They also identify a correlation between variation in composition and in characteristics and the type of building, probably related with more available resources for craftsmanship and for materials when important buildings are concerned, such as military and religious buildings [11]. These correlation is also a trend for other kinds of covering mortars [21]. For example, mortars richer in binder, with lower porosity and higher compressive strength, were identified in fortresses and churches, in second place in other public buildings, such as hospitals, and finally lower mechanical characteristics and higher permeability were found in housing buildings [11].

Many of these mortars are still in good conditions, especially those of important buildings (with better selection of raw materials and better craftsmanship) and in the interior (less exposed to water). The external claddings of common buildings show often higher degree of degradation (figures 2 and 6).

REQUIREMENTS

The requirements to take into account for reattachment mortars for old *azulejos* are related with:

- Compatibility – not increasing deterioration of the old pre-existent materials (*azulejos* and masonry);
- Reversibility – allow reversion of the repair, namely permit the detachment of the reattached *azulejo*, without irreversible damage of those historic elements, for example for cleaning and desalinate them, or to repair the wall, or any other reason;
- Functionality of the mortar (contribution to functionality of the cladding) – guarantee its foreseen functions, such as protection of the masonry and aesthetis;
- Durability – assure integrity of the works for a reasonable period of time.

The different types of requirements are often contradictory, so an adequate balance of properties must be reached. The following can be considered as the most important for reattachment mortars for old *azulejos* claddings [22, 23, 24]:

Fresh mortar: good workability and ability to penetrate in the ceramic body of the *azulejo*; high water retention in order to avoid dessecation when exposed to suction of both the substrate and the *azulejo* ceramic body.

- Mechanical characteristics: enough mechanical strength for adhesion under the tiles' weight (preventing falling of *azulejos*) and to ensure durability of the system, but lower than the substrate's for reversibility and for preventing damage of the masonry; avoid high modulus of elasticity, in order to be able to accommodate small movements of the substrate without transmitting stresses to the *azulejo* and without loss of adherence; adhesion strength is a key property for durability and functionality of the system, however, it should not be too high, in order to prevent damaging the substrate and also to allow reversibility.
- Hygric characteristics: water absorption by capillarity is not a very significant characteristic for setting mortars for *azulejos*, even for external use. On the other hand, the ability to dry fast and a high water vapour permeability are important factors, as the mortar should not act as water retainer or constitute a vapour barrier, which could promote concentration of moisture and affect adhesion.

The selection of the mechanical and hygric properties should use as reference the non-damaged pre-existent materials: old mortar, *azulejo* and masonry. Although it is not always possible to determine the characteristics of those elements, usually there are some studies in the literature of similar case studies that provide some information [25, 21].

Chemical characteristics: all the components, namely binders and aggregates, must be free of soluble salts, in order to avoid contamination of the system with additional salts beyond those already present in old masonry. Thus, cement or hydraulic lime with high contents of salts should not be used (Figure 7).

POSSIBLE SOLUTIONS

Considering the referred requirements, it is clear that modern adhesives and cement mortars should not be used. The compositions of low-porosity and high strength are considered inadequate.

The same goes, to a certain extent, for hydraulic lime mortars with the exception of natural hydraulic lime (NHL) mortars which have limited salt contents and usually more adequate mechanical characteristics, at least in the case of NHL3.5.

This deserves new mortars with characteristics that do not change the mechanical and physical properties of the tiled façade and that remain reversible, but is also critical that they are adequate and effective in terms of bond, guaranteeing durability of the system [26].

Taking also into account the knowledge of old setting mortars and performed experimental studies in the area, the following compositions proved to be the most adequate:

Binders: Air lime; natural hydraulic lime (NHL); air lime and pozzolans.

Aggregates: Well graded siliceous sand with a certain amount of fine grains; well graded siliceous sand with small amounts of non-expansive clay.

The raw materials should be free of significant amounts of salts.

Some compositions having shown good results in tests are (proportions in volume):

Air lime: siliceous aggregate 1:2

Air lime + pozzollan (e.g. metakaolin): siliceous aggregate 1:2

NHL 3.5: siliceous aggregate 1:3 (use only with medium strength masonry and tiles)

These mixes provide adhesion strength to old *azulejos* of 0.05-0.15 MPa, values similar enough to those obtained in old façades 0.02-0.07 [26]. These values are far from the requirements established by the European Standard EN 12004 [27] for adhesives for tiles. However, it is

important to point out that the scope of the standard is *adhesives* and not *reattachment mortars* and that specific standards for conservation of historic products are being prepared by the Technical Committee CEN/TC 346 “Conservation of cultural property”, of CEN (European Committee for Standardization).

APPLICATION

As in most traditional systems and always when air lime is involved, good application is a fundamental issue to the efficiency of the conservation work [28]. Some aspects to take into account are:

- Technical skills and experience of the applicator, who should know the details for efficient application, such as pressure or energy of application (Figure 8);
- Preparation of the substrate: repair (namely water infiltrations, cleaning), correct humidification and roughness (if necessary) to favour adhesion;
- Preparation of the tiles, by cleaning and decontaminating the ceramic body (from salts and biologic colonization) and by humidifying before application;
- Choose adequate climatic conditions and taking enough time for the several phases.

Moreover, full design specifications are needed for adequate materials and application conditions.



Figure 7: *Azulejos* façade cladding repaired with cementitious reattachment mortar showing degradation due to salts and high stresses



Figure 8: Repair of *Azulejos* façade cladding with air lime reattachment mortar by a skilled applicator (conservator / restorer)

CONCLUSIONS

Old *azulejos* claddings, both internal panels and claddings of 19th century façades, although they have proved good durability, are presently, in many cases, in urgent need of repair, to avoid fall and loss of historical *azulejos*. The reattachment of old *azulejos* should be made with adequate mortars, respecting requirements of compatibility and reversibility, as well as functionality and durability.

Being the connection element between tiles and masonry, reattachment mortars have important roles in the cladding system, contributing for durability, performance and even aesthetics of the façade.

Modern adhesive mortars, or any mortars with too high strength, high stiffness, low water vapour permeability or significant contents of soluble salts are to be avoided. Instead, lime-based mortars, with moderate mechanical and hygric characteristics and free of salts, must be used. Air lime, air lime and pozzolan, or natural hydraulic lime (NHL 3.5) may be used as binders and well graded siliceous sand, with small amounts of clay or with a siliceous filler should be used as aggregates, providing adhesion strength to the tiles and to the masonry in the range 0.05-0.15.

Application care and skilled workmanship are key issues. Moreover, design specifications should not be dismissed.

AKNOWLEDGEMENTS

The author acknowledges the Research Projects that made this work possible: Project PRESERVE – Preservation of renders and plasters of the Built Heritage with Cultural Value, financed by LNEC and Project PTDC/EPH-PAT/4684/2014 DB-Heritage – Data Base of construction materials with historic interest financed by the Portuguese Foundation for Science and Technology (FCT).

Bibliographic references

- ¹ BOTAS, S.; VEIGA, M.; VELOSA, A. – *Adhesion of Air Lime-Based Mortars to Old Tiles: Moisture and Open Porosity Influence in Tile/Mortar Interfaces*. J. Mater. Civ. Eng., 27(5), 2015, 04014161.
- ² SANTOS, T.P.; VAZ, M.F.; PINTO, M.L.; CARVALHO, A.P. (2012) – *Porosity and characterization of old Portuguese ceramic tiles*. Construction and Building Materials, 28(1), 2012, 104-110.
- ³ VAZ, M.F.; PIRES, I.; CARVALHO, A.P. – *Effect of impregnation treatment with Paraloid B-72 on the properties of old Portuguese ceramic tiles*. Journal of Cultural Heritage, 9(3), 2008, 269-276.
- ⁴ VELOSA, A.L.; VEIGA, M.R.; COROADO, J.; FERREIRA, I.M. – *Characterization of glazed ceramic tiles and mortars from façades of the city of Ovar for conservation purposes*, In Proceedings of International Seminar “Conservation of Glazed Ceramic Tiles. Research and practice”, April 15-16, 2009, Lisbon.
- ⁵ FERREIRA, Luis Mariz – *El azulejo de la arquitectura de Oporto [1850-1920]. Caracterización e intervención. Ph.D Thesis*. País Vasco: Facultad de Bellas Artes - Universidad del País Vasco, 2009.
- ⁶ BOTAS, S.; VEIGA, M. R.; VELOSA, A. – *Reapplication Mortars for Old Tiles: Characteristics of Tiles and Mortars and Selection Criteria*. International Journal of Architectural Heritage. (vol 8:1, pages124-139) January 2014, DOI:10.1080/15583058.2012.673690. ISSN: 15583058.
- ⁷ BOTAS, S.; VEIGA, M. R.; VELOSA, A. L. – *Adherence evaluation in tile-mortar interface*. Materials Science Forum 730-732, pp. 403-408. Published 2013. DOI:10.4028/www.scientific.net/MSF.730-732.403.
- ⁸ HENDRICKX, Roel; ROELS, Staf; VAN BALEN, Koenraad – *Water Transport between Mortar and Brick: the Influence of Material Parameters*, In Proceedings of 2nd Historic Mortars Conference HMC2010 and RILEM TC 203-RHM Final Workshop, 22-24 September 2010, Prague.
- ⁹ LAWRENCE, Mike; WALKER, Pete; ZHOU, Zhaoxia – *Influence of Interfacial Material Pore Structure on the Strength of the Brick/Lime Mortar Bond*, In Proceedings of 2nd Historic

Mortars Conference HMC2010 and RILEM TC 203-RHM Final Workshop, 22-24 September 2010, Prague.

¹⁰ VEIGA, M. Rosário – *Intervenções em edifícios antigos. Conservar, substituir ou... destruir. In 2º Encontro sobre Patologia e Reabilitação de edifícios*, In Proceedings of PATORREB 2006. Porto: 20-21 March 2006.

¹¹ DAMAS, A. L.; VEIGA, M. R.; FARIA, P.; SANTOS SILVA, A. – *Characterisation of old azulejos setting mortars: a contribution to the conservation of this type of coatings*. Construction and Building Materials, 171, 2018, 128-139.

¹² VELOSA, A. L.; COROADO, J.; ROCHA, F. – *Characterisation of stone and mortar decay – Casa Major Pessoa, Aveiro*, In Proceedings of HWC 2006, International Conference on Heritage, Weathering and Conservation, Madrid, Spain, 2006.

¹³ TEIXEIRA, B.; VALENTE, C.; VELOSA, A. L.; VEIGA, M. R.; FERREIRA, I.M. – *Development of lime based mortars for repairing glazed tiles coating of historic buildings in the city of Ovar, Portugal*, In Proceedings of HMC08, 1st Historical Mortars Conference, LNEC, Lisbon, Portugal, 2008.

¹⁴ FERREIRA, I.M. – *Traditional facade tiles in Ovar. Contributions to a conservation and restoration methodology (in Portuguese)*. Câmara Municipal de Ovar /ACRA – Atelier de Conservação e Restauro do Azulejo, 2009.

¹⁵ COROADO, J.; PAIVA, H.; VELOSA, A.; FERREIRA, V. M. – *Characterisation of renders, joint mortars and adobes from traditional constructions in Aveiro (Portugal)*, Int. J. Archit. Heritage 4 (2010) 102–114, <https://doi.org/10.1080/15583050903121877>.

¹⁶ JAPIASSÚ, P. – *Study of the adhesion mechanism of lime tiles and mortars in historic coatings (in Portuguese)*, MSc thesis, Goiás Federal University, Goiânia, Brazil, 2011.

¹⁷ ANDREJKOVICOVÁ, S.; PIRES, D.; FERREIRA, L.M.; VELOSA, A. L.; ROCHA, F.; LABRINCHA, J. – *Chemical and mechanical characterisation of Ovar mortars (in Portuguese)*, In Proceedings of Congresso Internacional Azulejar – Conservação de Revestimentos Azulejares em Fachadas, Aveiro University, Portugal, 2012, pp. 1–11.

¹⁸ CARASEK, H.; JAPIASSÚ, P.; CASCUDO, O.; VELOSA, A. – *Bond between 19th Century lime mortars and glazed ceramic tiles*, Constr. Build. Mater. 59 (2014) 85–98, <https://doi.org/10.1016/j.conbuildmat.2014.02.043>.

¹⁹ MENDES, M. T. – *Conservation and Restoration of Glazed Tiles. A Study of Setting Mortars (in Portuguese)*, MSc thesis, Lisbon University, 2008.

²⁰ MENDES, M. T.; ANTUNES, J.L.F.; COROADO, J. – *Conservation and restoration of glazed tiles. A study of setting mortars*, In Proceedings of HMC08, 1st Historical Mortars Conference, LNEC, Lisbon, Portugal, 2008.

²¹ VELOSA, Ana Luísa; VEIGA, Maria do Rosário – *Argamassas do Património Histórico: conhecer para conservar e reabilitar*. In Proceedings of CINPAR 2016 – XII Congresso Internacional sobre Patologia e Reabilitação de Estruturas, 26-29 October, 2016, Porto, Portugal.

²² VEIGA, M. R.; FARIA, Paulina – *O papel das argamassas na durabilidade das alvenarias antigas*. In Proceedings of Conferência Internacional sobre Reabilitação de Estruturas Antigas de Alvenaria – CIRea, 2018.

²³ BOTAS, Sandro; VEIGA, Rosario; VELOSA, Ana – *Air lime mortars for conservation of historic tiles: Bond strength of new mortars to old tiles*. Construction and Building Materials Volume 145 Pages 426-434, August 2017. DOI: 10.1016/j.conbuildmat.2017.04.027.

²⁴ BOTAS, Sandro; VEIGA, M. Rosário; VELOSA, Ana – *Argamassas para (re)aplicação de azulejos antigos. Um passo para a Normalização*. Revista Pedra & Cal, nº 61, julho a dezembro de 2016, pp 42-45.

²⁵ VEIGA, M. Rosário – *Argamassas de alvenarias históricas. Funções e características*. CIREA2012 – Conferência Internacional sobre Reabilitação de Estruturas Antigas de Alvenaria. 4 maio 2012, Universidade Nova de Lisboa. Editores: Fernando Pinho, Válder Lúcio, Carlos rodrigues, António Ramos, Paulina Faria, Manuel Baião, Paulo Lourenço, Humberto Varum, Ângela Nunes e Luís Moura. Pp. 17-27. ISBN: 978-989-20-3080-7.

²⁶ BOTAS, Sandro; VEIGA, Rosário; VELOSA, Ana - *Bond strength in mortar/ceramic tile interface - testing procedure and adequacy evaluation*. Materials and Structures (2017) 50:211. DOI 10.1617/s11527-017-1086-7.

²⁷ CEN – *Adhesives for tiles - Requirements, evaluation of conformity, classification and designation*, EN 12004, Brussels, 2012.

²⁸ VEIGA, M.R. – *Air lime mortars: what else do we need to know to apply them in conservation and rehabilitation interventions? (A review)*. Construction and Building Materials 157 (2017) 132–140.

Studies on azulejo glaze welding by means of laser irradiation

Sílvia R. M. Pereira

National Laboratory for Civil Engineering and HERCULES Laboratory - Evora University, Portugal, spereira@lnec.pt

Kostas Hatzigiannakis

Institute of Electronic Structure and Laser, Foundation for Research and Technology-Hellas (IESL-FORTH), Heraklion, Crete, Greece, kostas@iesl.forth.gr

Eleni Polychronaki

Institute of Electronic Structure and Laser, Foundation for Research and Technology-Hellas (IESL-FORTH), Heraklion, Crete, Greece, elenpo@materials.uoc.gr

Kristallia Melessanaki

Institute of Electronic Structure and Laser, Foundation for Research and Technology-Hellas (IESL-FORTH), Heraklion, Crete, Greece, alina@iesl.forth.gr

Paraskevi Pouli

Institute of Electronic Structure and Laser, Foundation for Research and Technology-Hellas (IESL-FORTH), Heraklion, Crete, Greece, ppouli@iesl.forth.gr

João M. Mimoso

National Laboratory for Civil Engineering, Lisbon, Portugal, jmimoso@lnec.pt

SUMMARY: This communication discloses a preliminary study about the effects of CO₂ laser irradiation on the surface of historic glazed tiles in order to test its potential for their restoration. The influence of the processing parameters (working distance, linear scanning velocity and number of laser scans) of a 25W CO₂ laser upon the welding of ceramic glazed surfaces was studied. Tile replicas simulating 17th -18th century historic Portuguese tiles of different glaze compositions and pigmented – non-pigmented glazes, have been irradiated. Optical reflection microscopy and SEM have been used to study the resulting morphological alterations. The welded glaze surface appears to be greatly affected by the employed lased parameters but also the different composition of the glaze and the presence of pigments. In general at optimized conditions the welding of the glaze is obtained even if newly formed macro and micro- cracks are usually observed in the vicinity or at the irradiated area. Initial results are encouraging and further work is necessary before the on-site and real-case implementation of this methodology.

KEY-WORDS: laser, azulejo, restoration

INTRODUCTION

Glazed ceramics are important items of cultural heritage interest which can constitute decorative and structural materials, often monumental in scope. Portuguese azulejos for example, are almost ubiquitously found as decoration in interior and exterior architecture and constitute one of the country most important expressions of a national artistic heritage. Their acknowledged resistance in external and moisty conditions have made them one of the preferred materials to protect and decorate Portuguese architectural structures. These characteristics have nevertheless the shortcoming that tiles are in many cases set in harsh environments subject to

pernicious weathering conditions. In those conditions their weathering-resistance capacity is limited and decreased during time when compared to their possibly “eternal” life when placed in non-moisture stable conditions [1]. This can be alarmingly observed by the increased degradation state that many historic tiles present nowadays. The harsh environmental conditions where many tile panels are placed; together with the restrictions as regards their move and/or transportation or the desire to leave them *insitu* increases also the demand upon their conservation and restoration treatments. A good restoration treatment for a tile panel in a museum environment for instance, will not necessarily be a good one for in-situ (sometimes outdoor) restoration since they need to be able to endure much harsher conditions. The lack of adequate conservation treatments to be applied in those settings is also a major issue and a constant complain of many professionals working in the field [2-4]. This lack has led us to the search for more efficient, compatible and durable conservation procedures leading us to explore the possible use of lasers for their conservation-restoration.

This article deals with a preliminary work on the innovative study of the potentials of using CO₂ lasers for the conservation and restoration of glazed ceramics. Therefore, the application of laser radiation based on the controlled thermal fusion of the glaze is presented and its potential is discussed.

On the use of lasers

Lasers have been established as most valuable tools for the study and conservation of Cultural Heritage objects and monuments, through spectroscopic and laser cleaning processes respectively [5]. The use of lasers for the cleaning of ceramic glazed surfaces is a field with limited research and applications. However, past works by Stratoudaki's et al [6] and Huet et al [7] have elaborated about the potential of using Nd:YAG and KrF lasers for removing pollutants from outdoor ceramics of the 19th century.

The cleaning processes which are up to now the only laser-based conservation processes, are based on the laser-ablation of materials by selective interaction between a laser beam and the unwanted material, leaving the core object untouched. During the interaction of the laser beam and the material a number of effects take place based on photothermal, photochemical and photomechanical mechanisms while the final result depends closely to the material properties and the laser parameters. An optimum laser cleaning result should ensure that only the desired mechanism will dominate and no unwanted effects would take place i.e. no melting, fracturing or chemical alteration will occur to the substrate (authentic surface) after cleaning. Nevertheless these undesirable effects may be of some use in the conservation field and in this respect the capacity of lasers to melt materials has been considered in this study.

The laser-induced thermal processing of materials has been already used since the eighties in industrial applications on utilitarian glass and ceramic materials. Specifically, in 1980 a patent has been issued on the use of CO₂ lasers to repair small defects on glass [8] and in 1987 another patent was issued on the repair of high melting temperature ceramic coatings such as in heat engines by injection and melting of a powdered material [9]. Later on, the use of lasers on the repair of whiteware ceramic articles has also been released [10-12]. Significant work has also been done on the engraving, by melting of a pigmented layer, on top of a ceramic material [13 - 17]. A Nd:YAG laser ($\lambda = 10.64 \mu\text{m}$ in continuous wave mode) has also been used to print coloured patterns on tiles [18].

Up to now little has been researched on the use of the thermal and melting potential of lasers in the conservation of cultural heritage ceramic artefacts. In 2014 Ristić *et al* have studied the impact of pulsed lasers on cleaning ceramics of historical importance [19]. Later Polić *et al* has studied the effect of pulsed lasers on the glaze surface also for restoration purposes [20]. After

the research made by FORTH and LNEC in 2016 a patent application (PCT/GR2016/000011) has been issued on the “Restoration of vitreous surfaces using laser technology” [21].

The possibility to heat and melt a small zone of the glaze without affecting the remaining tile is a great advantage compared to techniques such as re-firing [22, 23]. In re-firing the entire tile needs to be removed from the wall and is subject to a new firing cycle. Therefore the information regarding the production techniques that was stored in the materials is irreversibly altered. When re-firing - even when selecting a presumably appropriate firing program - due to the heterogeneity of the tiles and other unpredictable factors provides a certain risk to the procedure mainly because the final results can only be verified at the end while opening of the kiln. With localized welding the material is only affected locally in a range and a real-time operation where a more controllable procedure can be applied.

This article elaborates on preliminary studies made by these two institutions on the use of the above mentioned technique, namely the impact of the laser radiation upon glazed ceramic surfaces. The aim at this initial stage is to investigate the range of effects that may be caused on the glaze upon its irradiation at different laser parameters. This knowledge will allow us in the next stage to be able to determine the most appropriate irradiation conditions that would favour a “clean” melting without undesired results such as cracking and fracture, discoloration effects and other damages.

MATERIALS AND METHODS

Samples

Glazed ceramic tile replica samples with chemical glaze compositions similar to 17th-18th century Portuguese historical tiles [24] were made using two tin lead white glaze recipes (R1 and R2, Table 1). For the glazes preparation Tr29 and LT599 powdered frits from Ferro have been used and the chemical composition modified by adding silica powder (FPS 180 from Areipor), SnO₂ (Merck), K₂CO₃ (VWR chemicals), Na₂CO₃ (Riedel de Haen) and CaCO₃ (VRW prolabo).

The resulting powders have been mixed and fired at 980°C to make a frit. The frit has been then crushed to a lower than 106 µm granulometry, suspended in water and applied by immersion to the ceramic body. Part of the R1 samples (R1_b) were painted blue on top of the dry powder frit layer using a Cobalt Oxide pigment (Casa Viana). All samples have then been fired at 980°C for 30 min letting the kiln to cool down naturally.

Table 1: Theoretical elemental chemical composition of the replicas (based on the recipes)

	Na ₂ O (%)	MgO (%)	Al ₂ O ₃ (%)	SiO ₂ (%)	K ₂ O (%)	CaO (%)	TiO ₂ (%)	Fe ₂ O ₃ (%)	PbO (%)	SnO ₂ (%)
R1	1.2	0.5	3.8	47.7	6.7	1.1	0.1	0.1	30.9	7.8
R2	2.0	0.2	0.9	61.1	7.0	1.3	0.1	0.2	21.6	5.8

Experimental setup and methodologies

Laser processing

Preliminary tests with various laser types available at IESL-FORTH proved that Continuous Wave (CW) CO₂ lasers are the most suitable for this application. This was expected since CO₂ lasers emit in the far infrared (10.6 µm) thus causing only thermal effects on materials while the

CW operation does not allow high fluencies, as in the case of pulsed lasers, which may lead to ablation phenomena.

A custom made laser system was used for the irradiation of the samples. The main components of the system (Figure 1) were a) a 25W CW CO₂ laser (10.6 μm, Gaussian beam profile), b) an optical system for shaping and finally focusing the beam at 180mm c) flying optics (galvo system) to move the laser beam into the desired area and “draw” on the target the desired pattern and d) an elevation stage where the tiles were positioned in order to locate their glazed surface at the desired working distance.

The tiles were then irradiated with the following parameters: a) 12 W laser power (fixed value at which the laser was found to be more stable), b) working distance (wd), that is the distance from the sample/tile to the lens (Figure 2), varying from 135 to 180 mm (focus), c) scan speeds varying of 2.00, 26.81 to 53.62 mm/s and d) 1 up to 100 scans along the same irradiation line. On each sample a series of line-scans was performed, the scanning travel was larger than the tile width, starting and ending outside the tile to ensure uniform irradiation along the whole irradiated line.

Evaluation methods

SEM-EDS: A JEOL JSM 6390 scanning electron microscope was used for the evaluation of the samples irradiation. The SEM was operating at 20KV and a tungsten filament was used as an electron gun.

Reflection Optical microscope: A Olympus PMG3 reflection microscope has been used to observe the influence of the irradiation on the surface of the glazed ceramics.

μ- Raman: A compact portable Raman system with a diode laser (λ_{exc} : 785 nm) was used. The beam was focused on the surface of the sample to be analyzed by objective lens (x20) and the irradiation area had a diameter of about 20 μm. The beam power on the samples was 30mW. The typical exposure time was 5s, while 2scans were averaged.

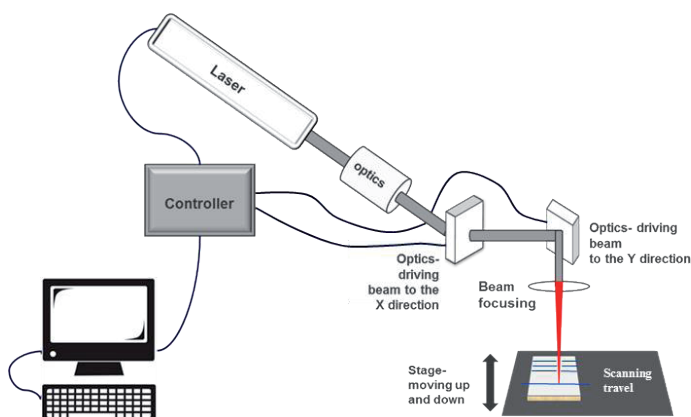


Figure 1: CO₂ laser set-up

RESULTS AND DISCUSSION

By visual inspection and depending on the irradiation parameters a number of effects could be recorded on the irradiated surfaces such as no observable effect, areas with increased gloss, craquelure, loss of material and in some cases discoloration (yellowing). Fig. 2 shows

microscope image of the type of resulting glaze welding effects observed at the surface of the tiles.

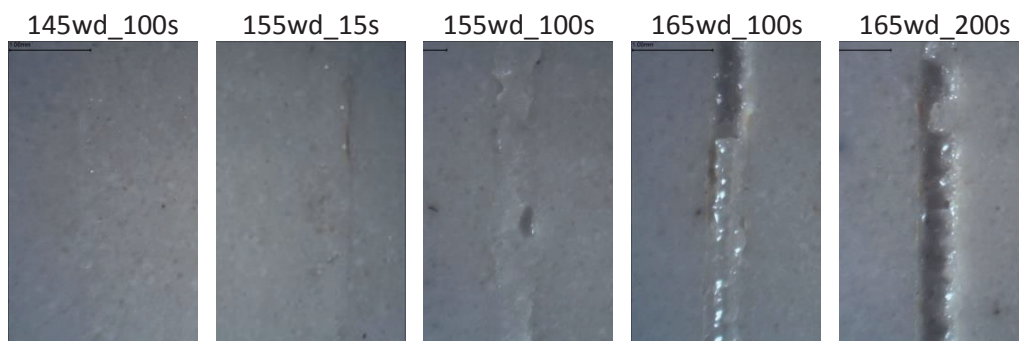


Figure 2: Microscopic observation of laser irradiation welding effects on the glazed surface for 53.62 mm/s velocity. a) No evident effect (145wd_100s); b) Crack along the irradiation line (155wd_15s); Multiple crack along the line (155wd_100s); Glaze welding and partial detachment (165wd_100s); Almost total detachment (165wd_200s). Where 'wd' is the working distance and the 's' the number of scans.

When looking in detail, whenever melting occurred, a constant crack network was observed both in the interface and the vicinity of the melted and non-melted glaze (Figure 2 and Figure 5). This crazing, was probably the result of the high temperature differences and inefficient heat exchange leading high thermal stresses between the two areas. At the surface of the melted lines a thin network of cracks was also developed. This was probably resulting from the different cooling rate and therefore due to the high temperature gradient between the melted surface and the melted inner-layers [11]. For working distances (wd) close to focus or lower velocities, besides melting, evaporation can be observed during the laser processing [20, 18]. The evaporation of glaze components, will also certainly affect the melted glaze composition. When irradiating, for instance glass bottles, it has been stated that alkaline and alkaline earth metal oxides were released leading to the decrease of the expansion coefficient of the melted glaze [25]. The resulting composition of the evaporated materials has not been analysed yet in our system but we would expect also an alteration of the melted glaze composition. A slight yellowing discoloration at the edges of the melted lines could also be observed. Through μ -Raman analysis yellow lead monoxide (β -PbO) could be detected (Raman shifts at 98, 158, 304 and 351 cm^{-1}) on the glaze irradiated samples (Figure 3).

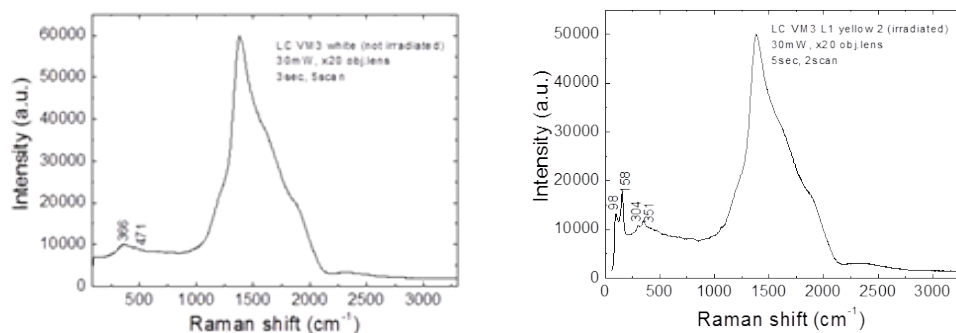


Figure 3: μ -Raman analysis of a non-irradiated and irradiated R1 glaze samples.

Through the observation of the samples by SEM the profile of the fissure system is more clearly observed (Figure 4). However, the depth of the melted glaze was not easily distinguished from the non-melted glaze and could only be estimated when a fissure occurred between both due to the thermal stress. As expected, in general, the melted zone was deeper and wider with increased energy density (close to focus, slow velocity and higher number of scans) It was also observed that within the tested conditions (laser parameters, glaze composition and thickness-around 200-500 μm) the melted glaze pool seemed not to reach the interface between the glaze and ceramic body.

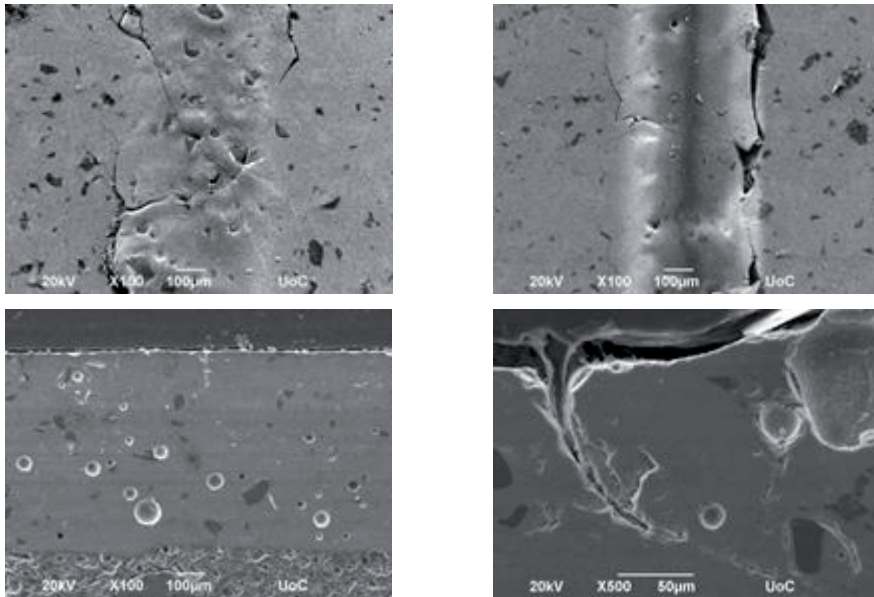
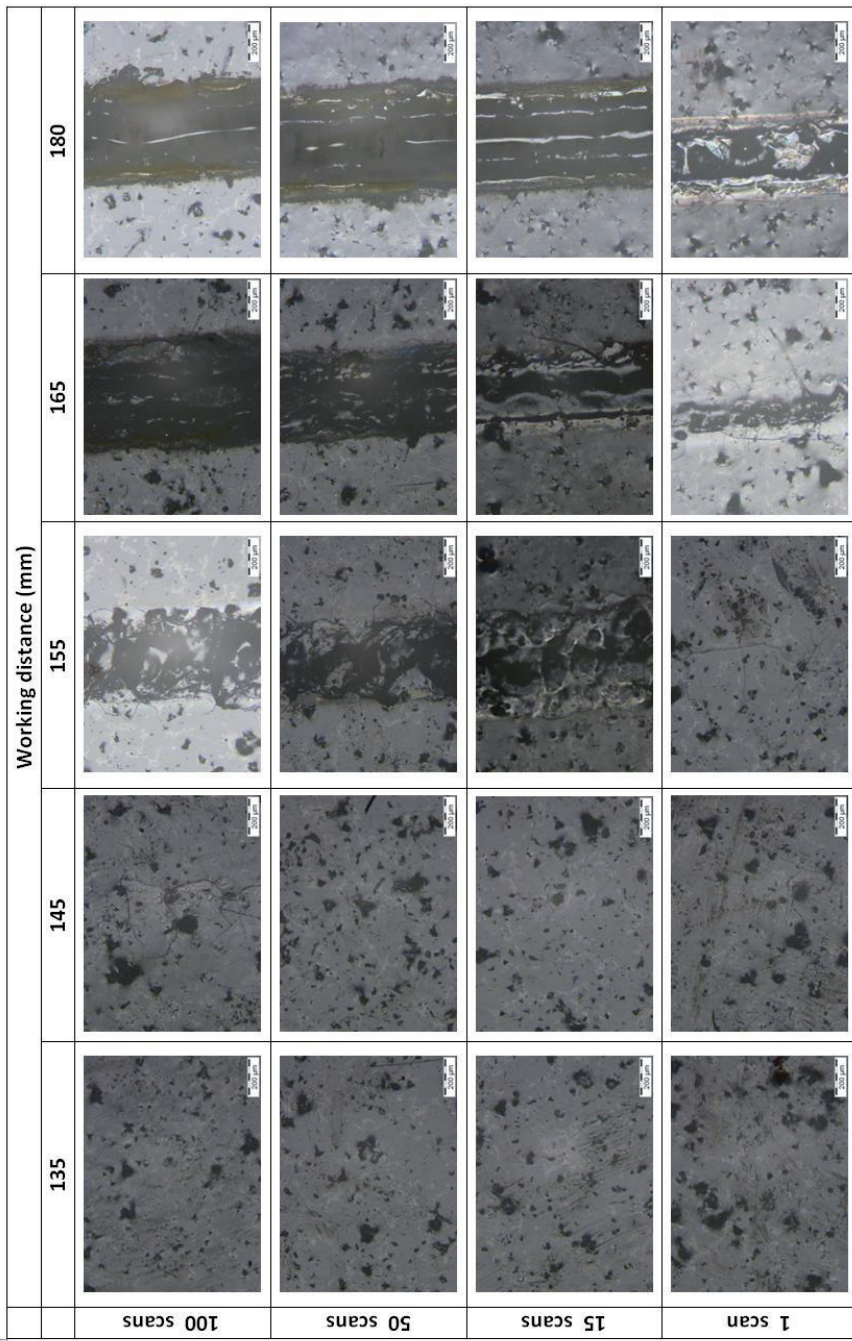


Figure 4: SEM analysis of R1 samples irradiated with a working distance/scans of 155wd/50s and 165wd/50s. Depending on the local the cross section is made the fissure between the melted and non-melted glaze can be seen or not.

Working distance and number of scans

Table 2 resumes the glaze surface alterations observed through reflection microscopy after irradiation at different working distances and number of scans at a constant velocity of 53.62 mm/s. It is observed that with a working distance of 135 mm (far away from focus) the glaze shows no visible alteration (Figure 5). When increasing the working distance to 145 mm a crazing network is already observable along the irradiated line with a higher crack density generally with increased number of laser beam scans. Apparently the energy delivered by the laser beam using this focal distance and speed is not enough to melt it but the crack network is still formed from the resulting thermal shock. Only when closer to focus (around 155 mm up to 180 mm - on focus) the glaze is melting. On average the melted line width increases when closer to the laser focus due to the delivery of higher amount of Energy. With 1 scan, only after 165 mm focal distance we could detect some minor glaze welding, but at the focus (180mm) a relatively homogeneous melted line was already observed. A large increase in line width is achieved from 1 to 15 laser scans while after this number this increase is lower (Figure 5).

Figure 5: Surface analysis of sample R1 by optical reflection microscopy (53.62mm/s)



Irradiating velocity

When decreasing approximately to half the scanning velocity (from 53.62 to 26.81 mm/s) an average increase of the melted line width is observed. This effect can be specially observed at 1 scan irradiation (Figure 5, 6, 7 and 8).

At 2mm/s and 1 scan, melting is observed at 145 working distance while at 26.81 and 53.62 mm/s melting is observed only at 155 and 165 lens-tile distance respectively. The higher energy resultant from a slower velocity allows the glaze to fuse at further away from the focus and at the velocity of 2mm/s the amplitude of the crack network is observed to be extremely high (Figure 7 and 8).

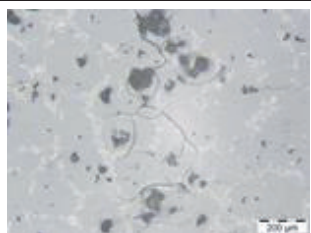

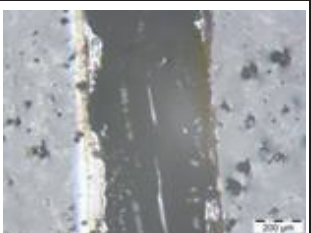
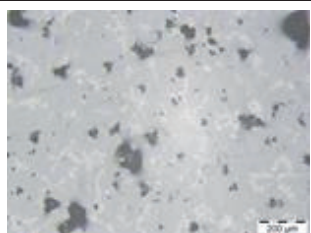

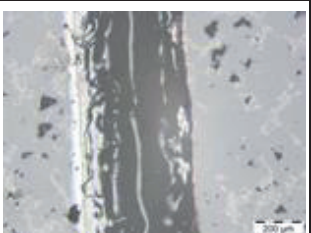
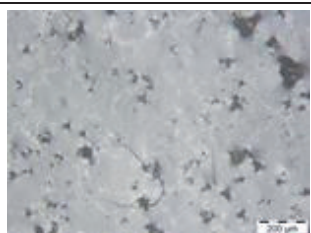
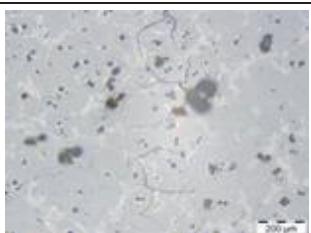
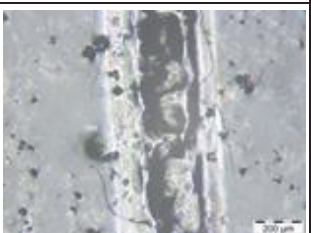
		Working distance (mm) at 26.81 mm/s		
		145	155	165
100 scans				
				
				

Figure 6: Surface analysis of R1 by optical reflection microscopy irradiated at 26.81 mm/s

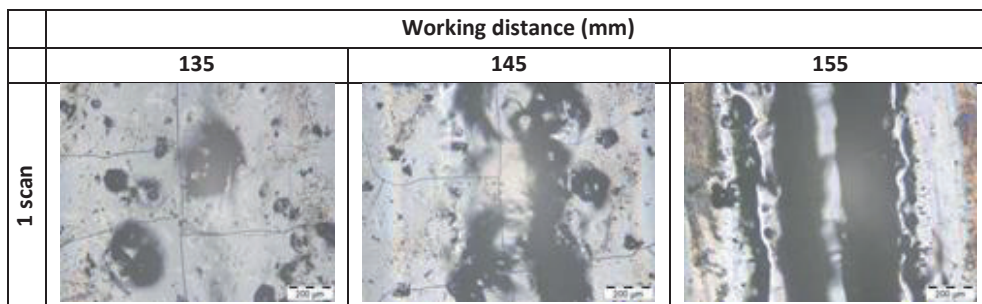


Figure 7: Surface analysis of R1 by optical reflection microscopy irradiated at 2 mm/s, 1 scan at 135, 145 and 155 working distance.

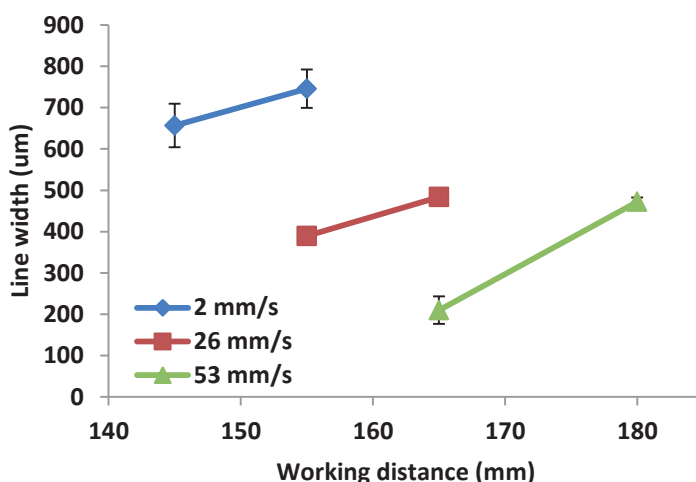


Figure 8: Effect of beam velocity and working distance on the melted line width after 1 beam scan.

Painted surfaces

Tiles are usually painted in one or more colours. Traditionally the pigments are applied as a liquid suspension to the raw glaze layer and then fired. When firing the pigments are mixed and integrated into the glaze layer showing usually a decreasing content from the surface of the resulting glaze layer (Figure 11) to the glaze-ceramic interface.

The pigments will certainly change the glaze properties such as its melting point. Cobalt oxide, responsible for the blue colour in tiles it is known to be a fusing agent and therefore the effect of the irradiation at the painted areas was largely enhanced. The average melting width was larger the results obtained for lower speed irradiation (Figure 6 and 10) and melting of the glaze was even observed for working distances of 145 and 50 scans (Figure 10).

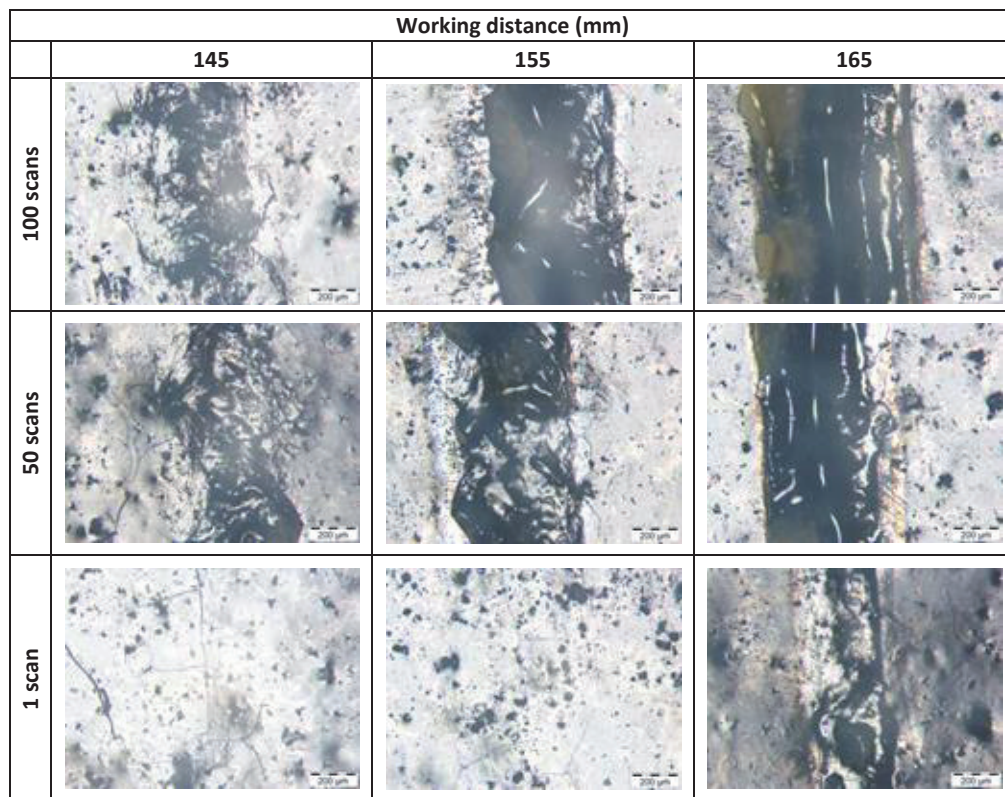


Figure 10: Surface analysis of R1 painted with blue with a Cobalt Oxide pigment by optical reflection microscopy irradiated at 53.62 mm/s

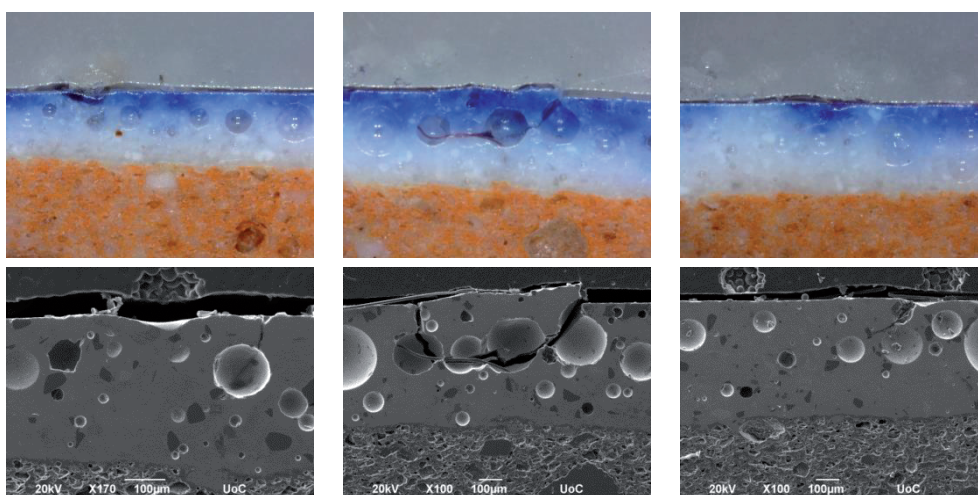


Figure 11: Optical microscopy and SEM analysis. From left to right: Working distance 165/1 scan with a small fissure, 155wd/50 scans with complete detachment, and 165wd/100 scans with a small detachment. Depending on the cross section zone it can be observed the fissure of the previously melted glaze or not.

Different glaze type

When different glaze compositions are used, a different resulting melting point of the glaze can affect its melting by laser irradiation. In this Case the R2 glaze originated on average a stronger glaze melting with melted glaze even at 155 working distance and 1 scan (Figure 12). These results show that the irradiation conditions would need to be tuned whenever a different tile glaze would be treated.

Figure 13 depicts the average width results for 50 scans and several working distances.

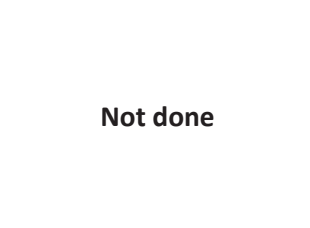


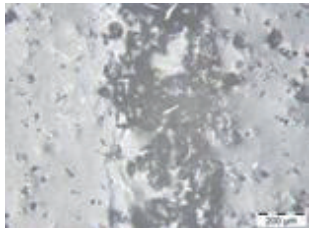


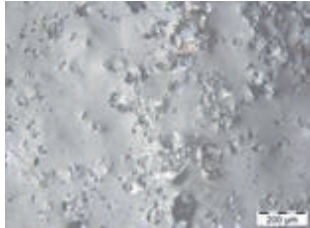
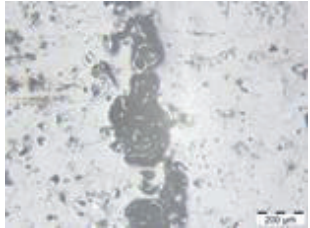
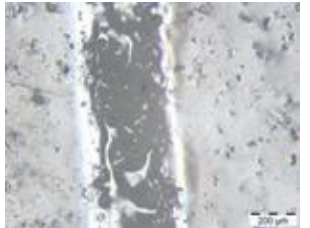
		Working distance (mm)		
		145	155	165
100 scans	Not done			
50 scans				
1 scan				

Figure 12: Surface analysis of R2 by optical reflection microscopy irradiated at 53.62 mm/s

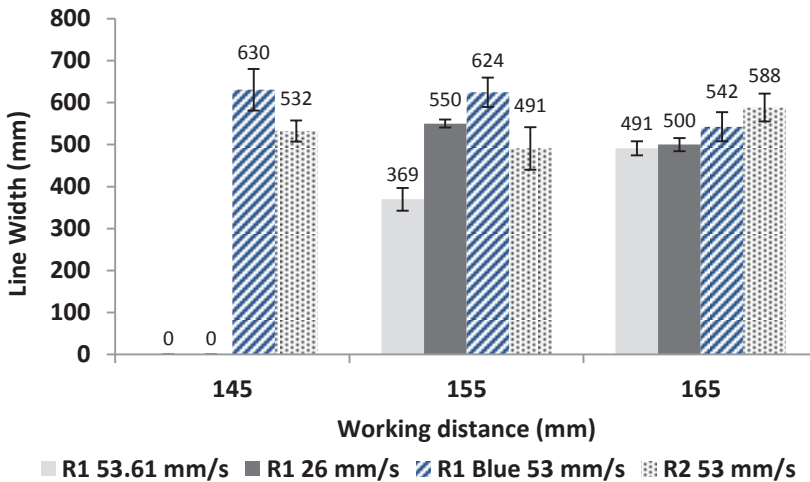


Figure 13: Effect of beam velocity and focal distance on the melted line width after 50 beam scans.

CONCLUSIONS

This present article is part of the common effort of two institutions to study the potential use of lasers in the restoration of glazed ceramics and dwells upon on the effect of the CO₂ laser irradiation on the glazed surface of historic tiles.

The laser was able to melt the irradiated areas while in certain cases undesired affects such as increased glossy appearance, crazing and in some cases yellowing was observed in the irradiated areas associated mainly with accumulated energy density.

In general the lines irradiated with higher accumulated energy (slower speeds and closer to the focus) are wider but the composition and presence of pigments of the glaze (due to differences in the melting point) are shown to also greatly affect the melted pool. The number of scans seems to be determinant up to a certain point (15- 50 scans) after which no substantial gain is observed. Advanced methods would need to be tested to decrease and ideally eliminate the resulting crazing.

The results obtained show that great care should be put in the selection of the laser parameters; the distance to the glaze surface plays a great role, but also velocity and number of scans. This optimization of parameters varies however when applying the irradiation on variations of types of glaze and even in different pigmented areas of the same glazed tile. An initial optimization would need to be made and the laser parameters adapted to the specific glaze on and pigments of the substrate.

Notwithstanding the necessary optimizations, CO₂ laser welding is a promising technique to treat ceramic tile and is a methodology that needs and deserves to be better researched.

Acknowledgements

The research has received funding from LASERLAB-EUROPE (grant agreement no. ulf-forth 002342, EU’s Horizon 2020 research and innovation programme). S. Pereira acknowledges FCT for her Post-Doc Grant (SFRH/BPD/116807/2016).

We acknowledge support of this work by the project “Advanced analytical, diagnostic, surveying and documentation technologies in Cultural Heritage (POLITEIA-II)” (MIS

5002478) which is implemented under the “Action for the Strategic Development on the Research and Technological Sector”, funded by the Operational Programme "Competitiveness, Entrepreneurship and Innovation" (NSRF 2014-2020) and co-financed by Greece and the European Union (European Regional Development Fund).

The authors thank Mrs Alexandra Manousaki for performing the SEM analysis and Dr Aggelos Philippidis for performing the Raman examination.

Bibliographic references

- [1] MIMOSO, J. M.; PEREIRA, S. R. M. - *Sobre a degradação física dos azulejos de fachada de Lisboa*. Relatório 303, LNEC-NPC, 2011.
- [2] MENDES, M.T.; PEREIRA, S. R. M.; FERREIRA, T.; MIRÃO, J., CANDEIAS, A. - *In Situ Preservation and Restoration of Architectural Tiles*. Materials and Procedures: Results of an International Survey, International Journal of Conservation Science, 6, 2015, 51-62.
- [3] MENDES, M. T.; TENNENT, N. H.; ESTEVES, L.; FERREIRA, T. A.; CANDEIAS, A.; DELGADO RODRIGUES, J.; PEREIRA, S. R. M. - *Lacunae infills for in situ treatment of historic glazed tiles*. Applied Physics A, 2016, 122(5).
- [4] MENDES, M. T. - *Conservação e Restauro de Azulejo: Metodologias de Intervenção vs Indicadores de Compatibilidade*. PhD Thesis, Évora University/LNEC, 2015.
- [5] FOTAKIS, C.; ANGLOS, D.; ZAFIROPULOS, V.; GEORGIU, S.; TORNARI, V.; - *Lasers in the Preservation of Cultural Heritage: Principles and Applications*. Taylor & Francis, New York, USA, 2006.
- [6] STRATOUDAKI, T.; MANOUSAKI, A.; ZAFIROPULOS, V. HUET, N.; PÉTRÉMONT, S., VINÇOTTE, A.. - *Cleaning of Ceramics Using Lasers of Different Wavelength., Optics and Lasers in Biomedicine and Culture*. Volume 5 of the Series of the International Society on Optics Within Life Sciences, 213-217, 2000.
- [7] HUET, N.; TANGUY, E.; VINCOTTE, A.; ZAFIROPULOS, V. - *Using lasers for cleaning ceramic and plaster patrimonial objects*. 19th Congress of the International Commission for Optics: Optics for the Quality of Life, Aug 2003, Florence, Italy. pp. 83, 2003
- [8] BROCKWAY, M.; Walters, C. - *Laser treatment method for imparting increased mechanical strength to glass objects*. US4338114 US Patent, 1980.
- [9] PETITBON, A. - *Method of surface-treating ceramic workpieces using a laser*. US Patent 4,814,575, 1987.
- [10] MURNICK , D. E. - *Localized surface glazing of ceramic articles*. EP patent EP 0 610 556 A1, 1993.
- [11] OSVAY, K.; KÉPÍRÓ, I.; BERKESI, O. - *Laser treatment of white china surface*. Applied surface Science, 252, 2006, 4516-4522.
- [12] KÉPÍRÒ I., Osvay, K ; Divall, M. - *Correction of small imperfections on white glazed china surfaces by laser radiation*. Applied Surface Science 253, 2007, 7798-7805.
- [13] GUGGER, H.; HERREN, F.; HOFMANN, M.; Pugin, A. - *Laser marking of ceramic materials, glazes, glass ceramics and glasses*. US Patent 4,769,310, 1988.
- [14] HARRISSON, P. - *High contrast surface marking using metal oxides*. US Patent 6, 313,436, 2000.

-
- [15] HORY, A. - *Method and device for marking objects with sintered mineral powders*. US patent application n° 20030012891, 2003.
- [16] RIECK A. S. - *Laser marking process for vitrification of bricks and other vitrescent objects*. US Patent 6,064,034, 2000.
- [17] HERREN F. - *Laser marking of ceramic materials, glazes, glass ceramics and glasses*. US Patent 5030551, 1990.
- [18] FERNANDEZ-PRADAS, J. M.; RESTREPO, J. W.; GÓMEZ, M. A.; SERRA, P.; MORENZA, J. L. - *Laser printing Enamels on tiles*. Applied surface Science 253, 2007, 7733-7737.
- [19] RISTIĆ, S.; POLIĆ, S.; RADOJKOVIĆ, B.; STRIBER, J. - *Analysis of ceramics surface modification induced by pulsed laser treatment*. Processing and Application of Ceramics 8 [1], 15-23, 2014.
- [20] POLIĆ, S.; RISTIĆ, S.; STASIC, J.; TRTICA, M.; RADOJKOVIĆ, B. - *Studie of the Iranian medieval ceramics surface modified by pulsed tea CO₂ and Nd:YAG lasers*. Ceramics International, 41, 2015, 85-100.
- [21] CHATZIGIANNAKIS, K.; POULI, P.i; MELASSANANKI, K.; BERNIKOLA, M. E.; MIMOSO, J. M.; PEREIRA, S. R. - *Restoration of vitreous surfaces using laser technology*. PCT/GR2016/000011, WO/2017/158390, 2016.
- [22] CHABBAN, A.; PEREIRA, S. R. M.; ESTEVES, L.; PEDDIS, F.; MIMOSO, J. M. - *Restoration of semi-industrial glazed ceramic tiles by re-firing*. GlazeArch 2015 conference Proceedings, 2015.
- [23] CHABAN, A. - *Restoration of semi-industrial glazed ceramic tiles by re-firing*. Master Thesis, Bolonha University/LNEC, 2015.
- [24] PEREIRA, S. R. M.; MIMOSO, J. M.; SANTOS SILVA, A. - *Physical chemical characterization of historic Portuguese tiles*. 23, NPC/NMM LNEC report, 2011.
- [25] HEINEKEN A. H.; BAUMERT, R.; GAAR, H.; HOFFMANN, U.; ROTH, U.; SCHWAMMLEIN, W. - *Method of, and apparatus for, repairing mechanical and/or chemical damage to the surface of bottles destined for re-use*. US Patent 4,731,254, 1988.

Validation of contactless vibro-acoustic imaging for the detection of glaze delamination in glazed ceramic tiles

Paola Calicchia

Institute of Marine Engineering CNR-INM, Rome, Italy, paola.calicchia@cnr.it

Sara De Simone

Institute of Marine Engineering CNR-INM, Rome, Italy, sara.desimone@idasc.cnr.it

Simone Privitera

University of Rome Tor Vergata, Rome, Italy, privi.simone@hotmail.it

SUMMARY: For glazed ceramic tiles, glaze delamination is a decay problem greatly demanding for effective risk-based preventive conservation. The present study faces the problem of the early detection of adhesion failure between the glaze and the clay substrate, exploring the potential of a vibro-acoustic imaging (VAI) technique in helping to prevent the glaze falls off and lacunas. The imaging technique is based on the Laser Doppler Vibrometry (LDV) joint to a contactless acoustic excitation of the tiles in the frequency interval (1 - 20) kHz. The results on historical Portuguese azulejos and laboratory models demonstrate that hidden cavities, a few hundreds of microns deep, are correctly identified and characterized.

KEY-WORDS: Preventive conservation; Glaze delamination; Vibro-acoustic imaging

INTRODUCTION

Painted glazed ceramics and particularly architectural ceramics, such as the traditional Portuguese azulejos, transmit the distinctive value of the culture in which their use has been developed during centuries. Although azulejos are a durable architectural finishing, very often they are at risk because many forms of deterioration progress leading to the final loss of the painted glazed layer and impair the comprehension of the related pictorial program. The integrity of the tangible assets as well as the knowledge of the intangible aspects have been at the centre of the scientific and cultural debate, that led in 1994 to the Nara Document on Authenticity [1] and continued in the successive decades. Within the Nara's framework, the understanding of the information regarding the original characteristics and the subsequent modifications are fundamental elements for assessing authenticity and so acknowledging the significance of those heritage assets of outstanding value. This specific knowledge must be considered in the heritage management, in the conservation and restoration planning, as well as within the inscription procedures to the World Heritage List.

These principles are also supported in the Australia ICOMOS Burra Charter for Places of Cultural Significance, 2013, where the conservation aim is stated to retain the cultural significance and identity value of a place [2]. Within its vision, the understanding and interpretation of the cultural significance of a place, including the analysis of the tangible and intangible assets, comes before the definition of the policy and the management of that place. Within very structured approaches in the cultural heritage management, also the concept of risk is considered as fundamental. For instance, in the manual for heritage risk management of the Canadian Conservation Institute [3] the risk is defined as “the possibility of a loss of value to the heritage asset”, and the measure of

the integrity of both tangible and intangible assets contributes to its assessment. The risk-based approach helps the most appropriate heritage management to accomplish preventive conservation actions, or to face the uncertainties and lack of knowledge that may arise. Therefore, all of the above considerations mean that any analysis, operation and intervention aiming at the conservation of a good must be done in the awareness that preserving the matter also means to preserve significance and values that the good represents.

For glazed ceramics, glaze delamination and spalling is a severe problem for the conservation and the preservation of their value. The high sensitivity of these assets to water-related deterioration is mainly associated to their structure characterized by the co-existence of the porous ceramic substrate, which may absorb water, and the glazed painted layer, which constitutes a barrier to water and to evaporation. Beside the difference of the hydric expansion coefficients of glaze and substrate, quite often the crystallisation of soluble salts is also present enhancing the damage. Another cause of damage is related to the presence of manufacturing defects such as an unsuitable difference in the thermal expansion coefficients of glaze and substrate [4]. The early detection of adhesion failure between the glaze and the ceramic substrate can improve the understanding of the damage progression before the glaze falls off and the lacunas impair the visual integrity of the artwork. Specific tools for accomplishing this task should identify hidden cavities a few hundreds of microns deep, when the appearance suggests integrity and the presence of detachments is still invisible to the naked eye. During the initial phase of the decay process, there might be too poor evidences allowing to correctly evaluate the actual state of the glazed ceramics, thus underestimating the rate of deterioration. A little decay advancement may lead to an abrupt increase of damage level to the heritage asset with an undesirable loss of materials, in particular the glaze, and a great loss of value. For this reason, specific technical tools should also indicate how the delamination expands, and if the probable stage of deterioration is incipient or advanced.

The present study explores the potential of a vibro-acoustic imaging (VAI) technique to help conservation actions in preventing the loss of glaze and the formation of lacunas. The imaging technique is based on the Laser Doppler Vibrometry (LDV) joint to a contactless acoustic excitation of the tiles in the frequency interval (1 - 20) kHz. In recent researches, the authors gathered interesting experimental evidences that vibro-acoustic techniques in the audio frequency interval can reveal thin glaze delamination both in historical tiles and in laboratory models with artificial cavities [5]. The present study extends the limits of these previous results, restricted to a few representative points, moving towards the imaging technique.

The main topic regards the laboratory validation of the proposed method to: i) reveal hidden cavities with different depth and shape; ii) correlate the cavity depth to characteristic features of the target acoustic response; iii) provide indications about the decay evolution in real tiles. For this purpose, two historical Portuguese azulejos and five laboratory models are analysed.

The experimental methods and procedure, the samples, the data analysis and the results will be discussed in the following paragraphs, with the purpose to show that the most appropriate use of the vibro-acoustic imaging technique for glazed ceramic tiles lays within the initial levels of materials damage, when no loss or modest loss of glaze is occurred.

VIBRO-ACOUSTIC IMAGING TECHNIQUES

Compared to other techniques, vibro-acoustic methods are particularly effective when applied to laminated materials and layered structures, affected by detachments and delaminations. Any part presenting a non-perfect adherence between adjacent elements may vibrate when exposed to acoustic waves. Among the most effective tools Laser Doppler Vibrometry is a well-known and widely assessed technique to reveal vibrations, adopted in many applicative fields with a great

variety of configurations [6]. Due to its high spatial resolution and non-invasiveness, laser vibrometry is successfully applied to cultural heritage objects (frescoes, mosaics, ceramics and different typology of paintings) to detect damage, and to verify the effectiveness of restoration interventions [7]. Moreover, when it is employed with a contactless acoustic excitation source, it provides accurate information with a higher level of non-invasiveness, particularly suitable for fragile artworks.

For a better understanding of the samples behaviour, we recall that a delamination forms a sub-surface air cavity that vibrates at specific frequencies when it is excited by a suitable external acoustic pressure field. Any such system has a number of preferred ways to vibrate that are called the normal modes of vibration, the fundamental mode and the high-order modes, whose characteristic frequencies depend on the geometrical and physical properties of the sub-surface cavity. For cavities having regular geometrical characteristics, approaching ideal systems, the frequencies of the normal modes are calculated and the displacement of the surface follows characteristic vibration patterns [8]. Conversely, in many real cases the irregular shape of the detached areas requires numerical methods for performing the vibration analysis [9]. However a hidden cavity can be represented as a *mass - air spring* system, where the mass M is concentrated in the superficial layer and k_{air} is the spring rigidity of the air volume inside the cavity. For this system the frequency of the fundamental mode of vibration f_0 (the mode with the lowest frequency) depends on the density of air ρ_0 , on the density of the surface layer ρ_s and its thickness t , and on the depth of the air cavity d , as expressed in Equation 1

$$f_0 = (1/2\pi)\sqrt{k_{\text{air}}/M} = (c_0/2\pi)\sqrt{\rho_0/(\rho_s t d)} \quad (1)$$

where c_0 is the velocity of sound in air. The density ρ_s and the thickness t of the surface layer may vary from object to object, while the air cavity depth d is related to the stage of the decay process, from an early stage thin delamination to an advanced stage thick delamination. Equation 1 shows the inverse proportionality between the characteristic vibration frequency f_0 and the cavity depth d , thus as a general rule of thumb it can be stated that:

- an incipient thin delamination will vibrate at a high frequency (low d value and high f_0 value),
- conversely an advanced thick delamination will vibrate at a lower frequency (high d value and low f_0 value).

Laser Doppler Vibrometry with contactless acoustic excitation

Laser Doppler Vibrometry allows the contactless measurement of vibration velocity and displacement of a surface, based on the optical interferometry. A critical issue is the choice of the excitation source, used to induce the desired vibration in the analysed object. In literature, many studies can be found where different excitation tools are adopted, such as impact hammers, piezoelectric actuators and loudspeakers [6 - 7]. Laser vibrometry joint to a contactless acoustic source, that induces the desired vibration in the analysed object, becomes a powerful tool for non-destructive evaluation and non-invasive diagnostics.

The main element of the Laser Doppler Vibrometer (LDV) is the optical sensor head that englobes the interferometer [10]: the laser source emits the *primary beam* that is divided into two coherent beams of equal frequency and phase, one is the *reference beam* and the second is the *measurement beam*. The *measurement beam* is focused at the surface of the investigated object, is reflected back inside the optical sensor head, again into the interferometer where it is re-combined to the *reference beam*. The *reflected beam* carries the information about the target movement, i.e. its vibration velocity. After re-combination of the two beams, the difference between them is processed by the LDV controller processor in order to extract the target velocity and displacement. In particular, the velocity output from the controller provides an output voltage U

directly proportional to the velocity v of the vibrating surface; according to Equation 2 the vibration velocity is obtained by multiplying U by a constant σ (expressed in mm/s/V) that depends on the selected range setting:

$$v \text{ [mm/s]} = \sigma \text{ [mm/s/V]} \times U \text{ [V]}. \quad (2)$$

In this work the velocity amplitude was measured by means of a Polytec Single Point LDV, composed of the optical sensor head OFV303 and the controller processor OFV-3001-S.

A commercial Parametric Acoustic Array PAA, the Audio Spotlight by Holosonics (HAS8), was selected as contactless acoustic excitation source for its interesting features: a flat and small sized transducer (20 cm × 20 cm) characterized by a very narrow audio beam. The HAS8 source is equipped with a control unit that delivers an acoustic wave towards the analysed surface, and allows to regulate the output level and to balance the low frequency and high frequency content of the emitted wave. The properties and stability of the HAS8 emission were verified/monitored by measuring the Sound Pressure Level SPL in the audio frequency interval at the target position, i.e. at a distance of 60 cm from the source along its central axis.

The optical sensor head of the LDV operated in the horizontal plane, while the acoustic source and the analysed sample were mounted vertically with their central axis in the horizontal plane; furthermore, all these elements were individually fixed on an antivibration table as schematically shown in Figure 1 (a, b).

The acoustic source and the laser sensor head were located at 60 cm from the sample's surface, this last mounted on a motor controlled linear guide allowing its positioning in front of the measuring system. A National Instruments 16-bit multifunction data acquisition board (NI-USB6221) and a personal computer completed the measuring system, performing the acoustic wave generation, the acquisition of the vibration velocity and its processing.

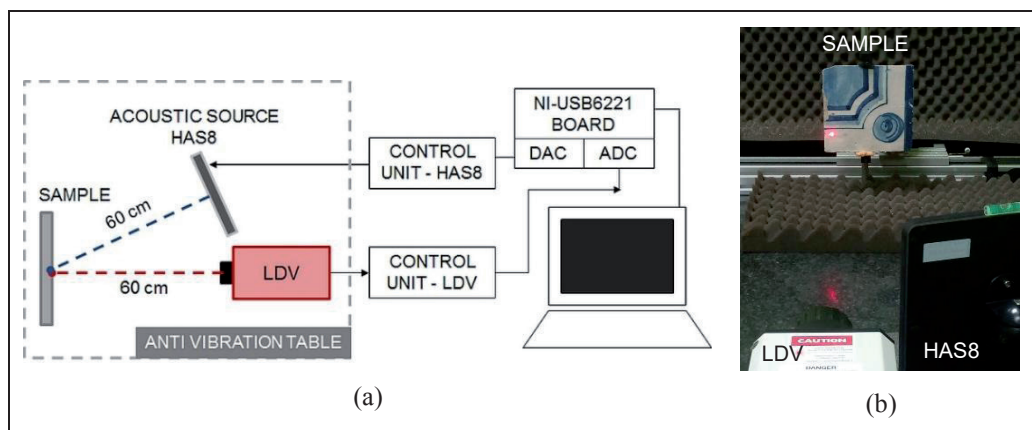


Figure 1: Scheme of the experimental setting (a), and image of the equipment during measurement (b).

THE SAMPLES

A collection of heterogeneous tiles constitutes the set of samples analysed in the present work, among which both historical Portuguese azulejos and manufactured laboratory models are included. The set of tile samples is presented in Figure 2: the laboratory models are shown on the left while the azulejos are on the right. The samples A1 and T3, in the upper part of the figure,

were selected for their apparent integrity and used as reference tiles in the comparison with the other samples, shown at the bottom of the figure. The relevance of the vibrational response of the samples needs to be interpreted in the comparison with the behaviour of the reference tiles that is expected to present no vibration, or at least very little ones. Belonging to a little collection of azulejos dated between the 17th and the 18th century, the two samples A1 and A7 were considered suitable for the present study due to their presumed conservation states, very different at the visual inspection. A1 was selected as reference azulejo because no evident glaze delamination appears and an overall good conservation state can be inferred; conversely, A7 was selected because of the presence of an evident glaze delamination and a lacuna, while the decay process is likely to progress around it.

The laboratory models include four samples with different in shape and depth artificial cavities, T1 - T11 - T12 - T13, and one without defects T3. The models were manufactured assembling thin technical glasses of the type SCHOTT D 263[®] LA eco (having thickness 0.7 mm, and density 2.51 g/cm³) [11] on small clay substrates using epoxy glue. The physical properties of these technical glasses and of the epoxy glue allowed simulating the physical properties of real tiles in vibro-acoustic phenomena. The manufacturing process was carried out at room temperature using epoxy glue with medium drying time (30 min) to prevent cracks during the drying process. The main features of the samples are summarized in Table 1.

In particular, T3 was assembled fixing only one thin glass on the clay substrate, spreading the glue over the entire surface. T3 does not present any cavities, so that it represents the suitable reference tile for the set of laboratory models.

For the model T1 few pieces of ordinary microscope glass, 0.8 mm thick, were cut and fixed on the clay substrate in order to build the side walls of a square cavity. Successively, the thin D 263 glass was fixed as capping layer upon the previous one, thus forming a hidden cavity having a resulting thickness of 1.3 mm.

In order to minimize the cavity thickness, for the other three models a different manufacturing process was adopted, building up the cavity's walls only with the epoxy glue. Specifically, for T11 a first uniform layer of glue was spread over the back surface of the thin technical glass used as cap layer, masking a little area to shape the cavity; after drying, a second layer of epoxy glue was uniformly spread over the first layer, in order to fix the whole to the clay substrate. It resulted a hidden square cavity having a final thickness of 0.8 mm. For T12 a similar procedure was followed, but only one layer of epoxy glue was spread on the back of the thin glass and suddenly fixed to the clay substrate before drying. Thus, it resulted a thinner square cavity having a final thickness of 0.4 mm. T13 was built following the two steps procedure like T11, masking a triangular area to shape the cavity. It resulted a hidden triangular cavity having a final thickness of 0.6 mm. The manufacturing process was essentially a handmade procedure, however particular attention was paid during any single phase in order to uniform each model's thickness, and obtain flat surfaces and regular cavities as much as possible.

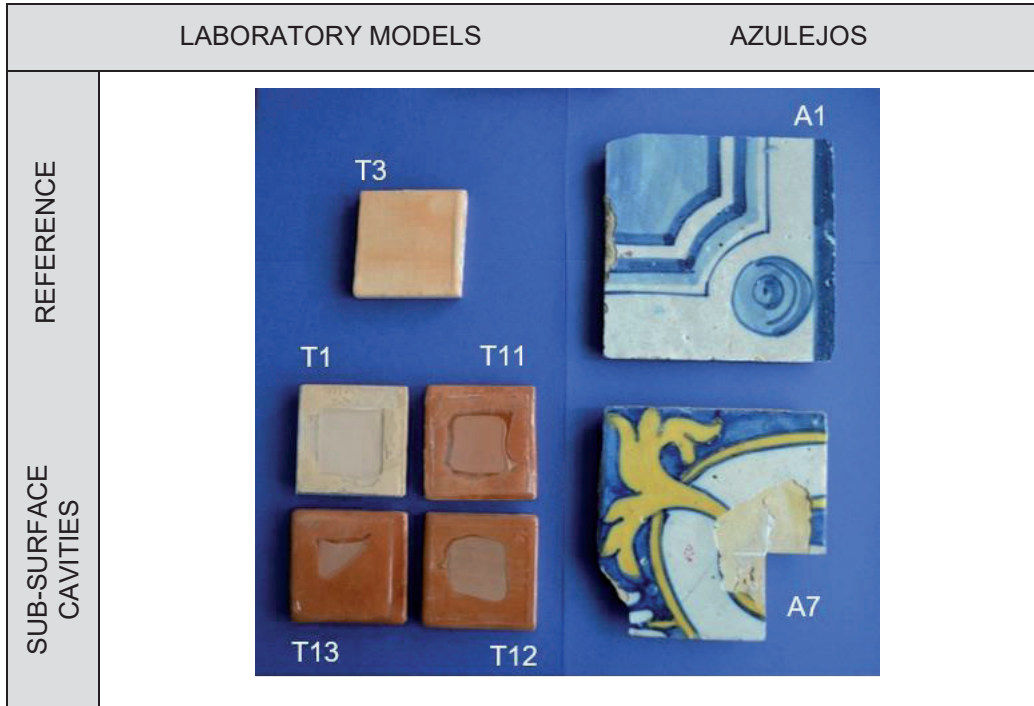


Figure 2: Collection of tile samples including five laboratory models T1 - T3 - T11 - T12 - T13 on the left, and two antique azulejos A1 and A7 on the right.

Table 1: List and details of tile samples under study.

ID	MATERIALS and SIZE (mm3)	CAVITY (mm3)	NOTES
A1	clay with white and blue glaze 143 × 143 × 11.6		Tile with no apparent delamination
A7	clay with white, yellow and blue glaze 140 × 140 × 14.3		Tile with significant delamination, and lacuna
T1	clay substrate and glass 68.0 × 68.0 × 9.6 substrate 68.0 × 68.0 × 11.6 substrate + glass	42 × 42 × 1.3 square cavity	0.8 1st layer glass 0.7 cap layer glass 2 layers of glue
T3	clay substrate and glass 68.0 × 68.0 × 9.6 substrate 68.0 × 68.0 × 11.2 substrate + glass		0.7 cap layer glass 1 layers of glue
T11	clay substrate and glass 70.0 × 72.0 × 10.5 substrate 70.0 × 72.0 × 11.9 substrate + glass	34 × 37 × 0.8 square cavity	0.7 cap layer glass 2 layers of glue
T12	clay substrate and glass 71.8 × 70.6 × 10.8 substrate 71.8 × 70.6 × 11.8 substrate + glass	37 × 37 × 0.4 square cavity	0.7 cap layer glass 1 layer of glue
T13	clay substrate and glass 72.6 × 70.8 × 10.7 substrate 72.6 × 70.8 × 12.2 substrate + glass	35 × 28 × 0.6 triangular cavity	0.7 cap layer glass 2 layers of glue

EXPERIMENTAL PROCEDURE AND DATA ANALYSIS

The experimental setup depicted in Figure 1 was adopted for testing the entire collection of samples. After alignment with the laser beam, the sample under study was moved along the vertical and horizontal axes, in the XY plane orthogonal to the laser beam, to build a 2D matrix of analysed points over its surface. The acoustic source and the LDV sensor head were kept fix. For each point of analysis, the measuring procedure consisted in feeding the acoustic source with pure tones of audible frequencies, in the wide interval 1 kHz up to 20 kHz depending on the sample, radiating the acoustic wave towards the sample and acquiring the velocity output voltage from the LDV controller. Details of the measurement settings used for each sample are schematically reported in Table 2.

Table 2: Measurement settings used for the different samples.

ID	MATRIX	FREQUENCY RANGE	LDV RANGE
T1	5 × 5; 25 points; 15 mm step	(1 – 10) kHz; 100 Hz step	5 mm/s /V
T3	5 × 5; 25 points; 13 mm step	(1 – 10) kHz; 100 Hz step	5 mm/s /V
T11	5 × 5; 25 points; 13 mm step	(1 – 16) kHz; 100 Hz step	10 mm/s /V
T12	5 × 5; 25 points; 13 mm step	(1 – 20) kHz; 100 Hz step	10 mm/s /V
T13	6 × 6; 36 points; 10 mm step	(1 – 20) kHz; 100 Hz step	10 mm/s /V
A1	7 × 7; 49 points; 20 mm step	(1 – 16) kHz; 100 Hz step	10 mm/s /V
A7	9 × 9; 81 points; 15 mm step	(1 – 16) kHz; 100 Hz step	10 mm/s /V

The single point measurement provided the vibration velocity expressed as function of frequency $v_i(f)$, in mm/s, where the index indicates the i-th point. A suitable data post-processing was applied to the set of functions in order to transform them into a set of matrices useful to provide the images in specific frequency bands. The main steps of this data processing are described hereafter, and schematically reproduced in Figure3.

For a specific sample, the starting dataset is the collection of functions $v_i(f)$ for the number of measuring points:

- a) After a background noise subtraction, to improve the quality of the resulting images, the functions $v_i(f)$ are processed in the following way: the whole frequency interval is divided into narrower bands Δf (nominally 1/3 octave bands that are commonly used in many acoustics applications) represented by their central frequency f_{cn} ; inside each frequency band the maximum velocity value v_i^{max} is extracted and associated to f_{cn} . The use of the maximum value guarantees that all velocity profiles are well reproduced without any loss of information, also those profiles presenting very narrow peaks.

At this stage the intermediate dataset is a collection of discrete functions $v_i^{max}(f_{c1}, f_{c2}, \dots, f_{cn})$ reproducing the same profile of the original functions through a smaller number of data points.

- b) The successive step consists in the arrangement of the new values v_i^{\max} in the final 2D matrix corresponding to each frequency band f_{cn} .

The output dataset is a collection of matrices $V^{\max} [f_n]$:

- c) These matrices are displayed as vibro-acoustic images (after the application of a bi-cubic interpolation to improve the final image quality), thus representing the response of the analysed sample in the different frequency bands. The experimental results are presented as colour maps superimposed on the sample photograph. For the sample under study, the colour scale of the map is specifically selected in order to range from blue (zero vibration velocity) to red (corresponding to the highest vibration velocity value).

This procedure gives the advantage of dealing with a small number of images that represent the entire and potentially meaningful frequency interval.

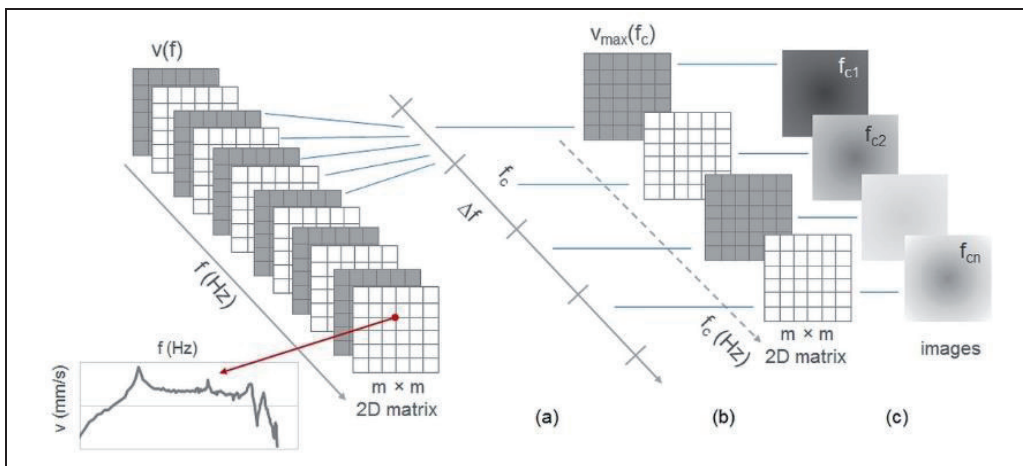


Figure 3: Scheme of the data post-processing, from left to right, transforming the initial datasets of vibration velocity in simpler matrices, finally displayed as vibro-acoustic images.

RESULTS AND DISCUSSION

In the present paragraph the sequence of vibro-acoustic images are reported for each sample from Figure 4 to Figure 10. The sequences report the most significant frequency bands, covering the entire extension of the frequency interval used in the tests and evidence the bands where the normal modes of vibration are clearly visible. The frequency resolved images are presented in the small format, while the most relevant one, where the velocity peak falls, is bordered in white and also reproduced in wide format. The velocity peak and its corresponding frequency band are also reported aside as an additional information.

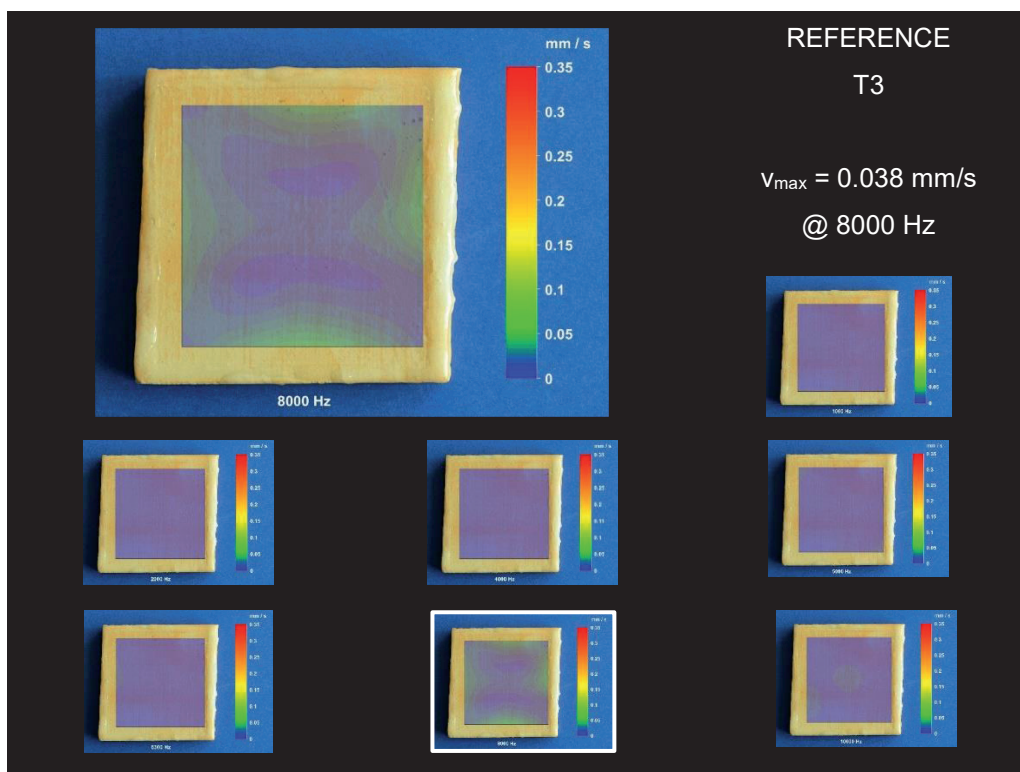


Figure 4: Vibro-acoustic images on T3, in the most significant frequency bands. The velocity peak falls in the 8000 Hz image, bordered in white and reproduced in wide format.

The colour scale used for T1, T3 and T13 ranges from 0 mm/s (bleu) to 0.35 mm/s (red), that is near the velocity peak value found on the samples with cavities, while the values for the intermediate levels (green and yellow) have been selected to correctly visualize the behaviour of other relevant points. Similarly, the colour scale used for T11 and T12 ranges from 0 mm/s to 0.7 mm/s, with the intermediate levels scaled according to the same principle. Again, the colour scale used for A1 and A7 ranges from 0 mm/s to 0.35 mm/s, as for the first models, but with slightly different values for the intermediate levels.

As expected, the reference model T3 (Figure 4) does not present much relevant features compared to the other samples: the velocity values are one - two orders of magnitude lower than the values found in the other models, and this issue confirms its correct behaviour as reference.

The images obtained on the laboratory models with hidden cavities (Figure 5 to Figure 8) indicate a considerably different behaviour with respect to the reference model T3. The fundamental vibration mode is clearly visible (at the lowest frequency band with non-zero vibration velocity), together with some higher modes in the images corresponding to the multiple frequency bands.

They also show the discrimination of the hidden cavity from those points, on the same sample, where the glass is glued to the ceramic body and presents a perfect adherence. The availability of models with cavities a few hundreds of microns deep allows to demonstrate that the vibro-acoustic imaging in the audio frequency interval successfully reveals the position of thick and thin delaminations, and approximately identifies their shape and extension. As expected, the significant frequency band grows as the cavity depth decreases.

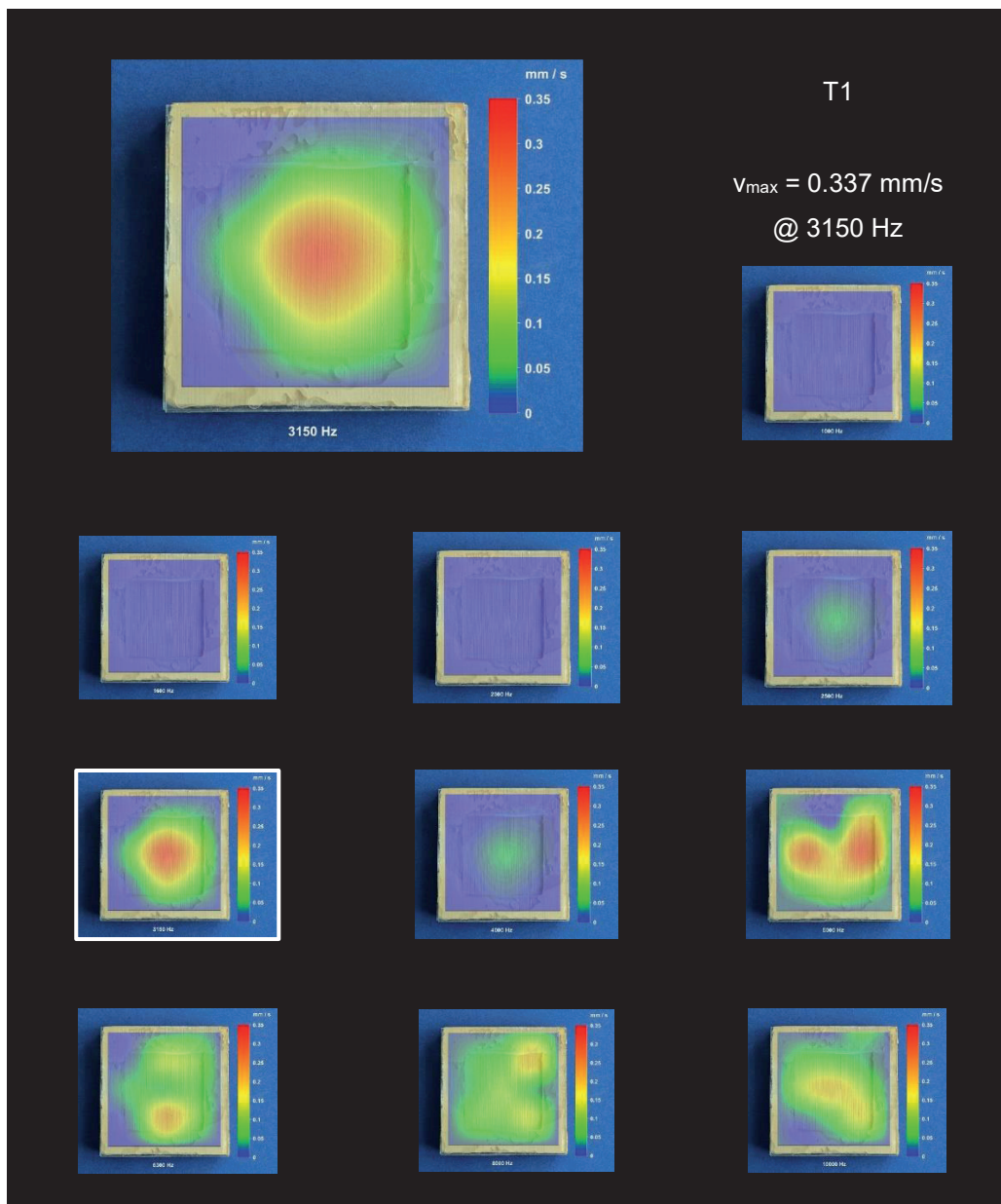


Figure 5: Vibro-acoustic images on T1, in the most significant frequency bands. The velocity peak falls in the 3150 Hz image, bordered in white and reproduced in wide format.

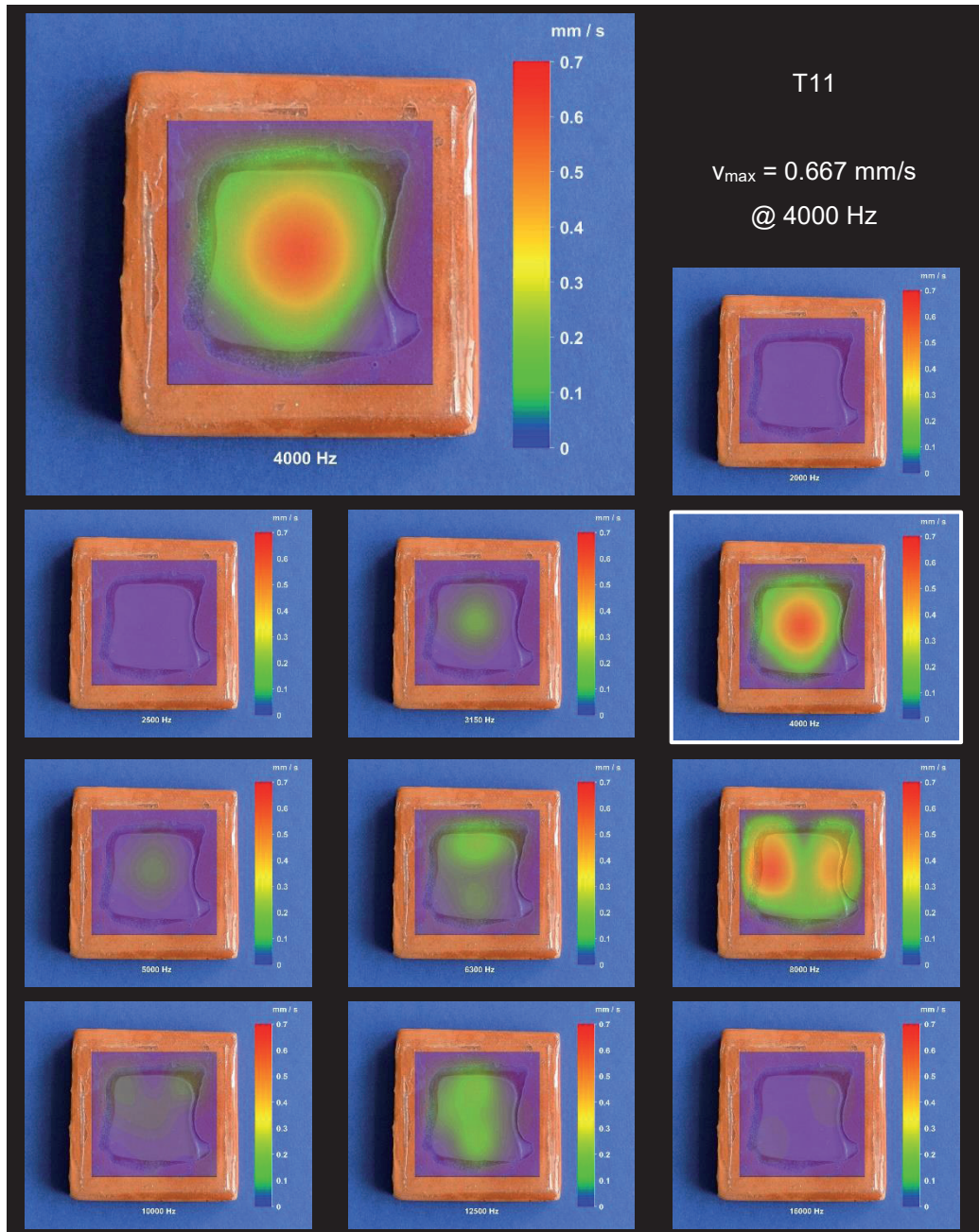


Figure 6: Vibro-acoustic images on T11, in the most significant frequency bands. The velocity peak falls in the 4000 Hz image, bordered in white and reproduced in wide format.

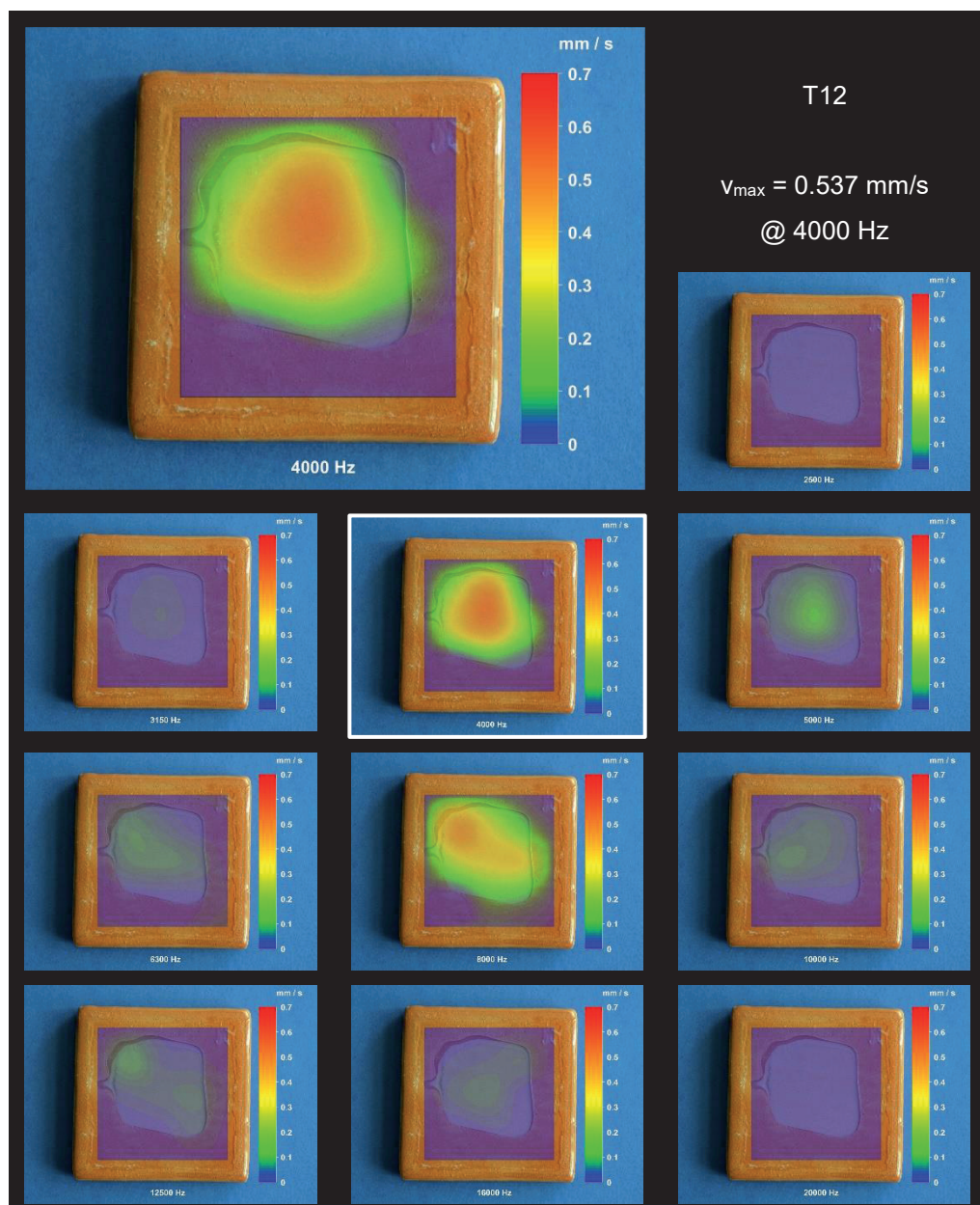


Figure 7: Vibro-acoustic images on T12, in the most significant frequency bands. The velocity peak falls in the 4000 Hz image, bordered in white and reproduced in wide format.

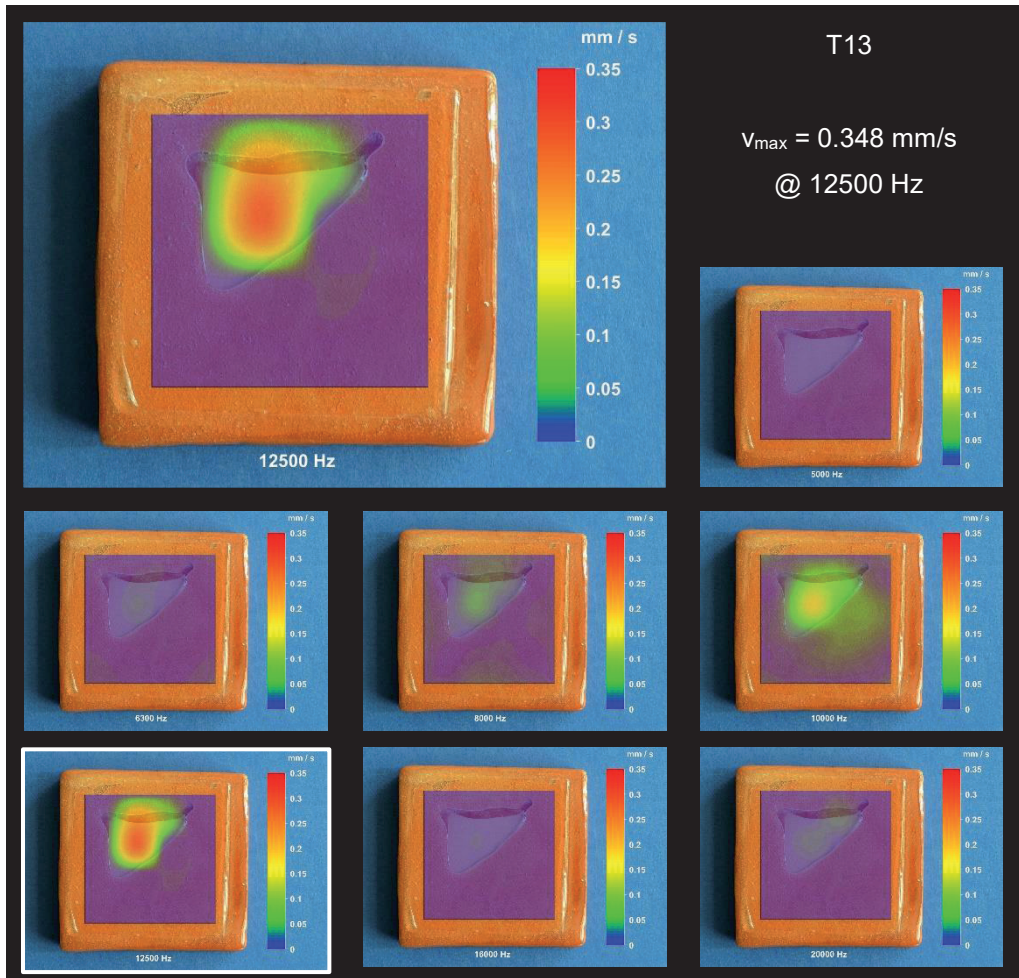


Figure 8: Vibro-acoustic images on T13, in the most significant frequency bands. The velocity peak falls in the 12500 Hz image, bordered in white and reproduced in wide format.

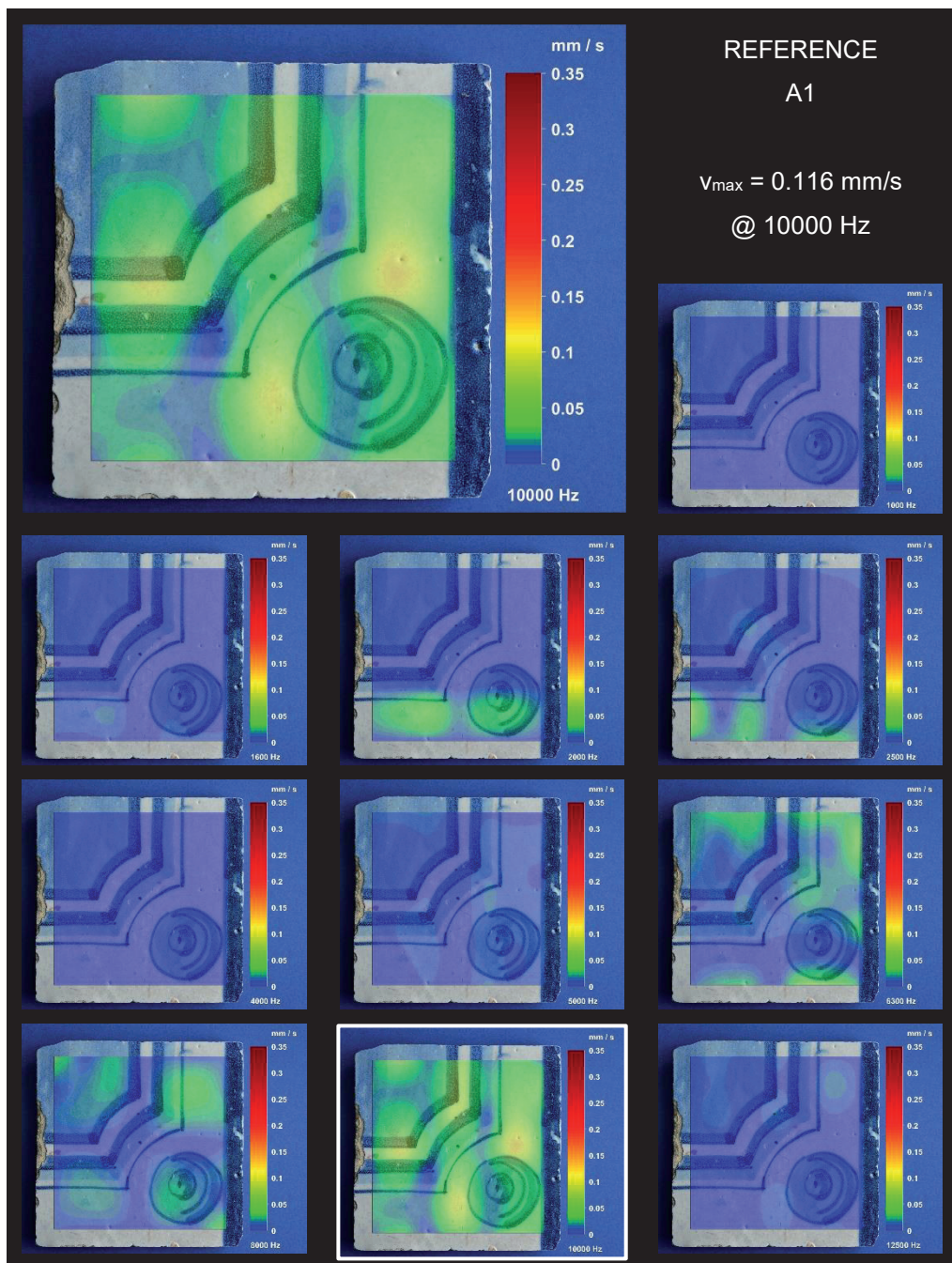


Figure 9: Vibro-acoustic images on A1, in the most significant frequency bands. The velocity peak falls in the 10000 Hz image, bordered in white and reproduced in wide format.

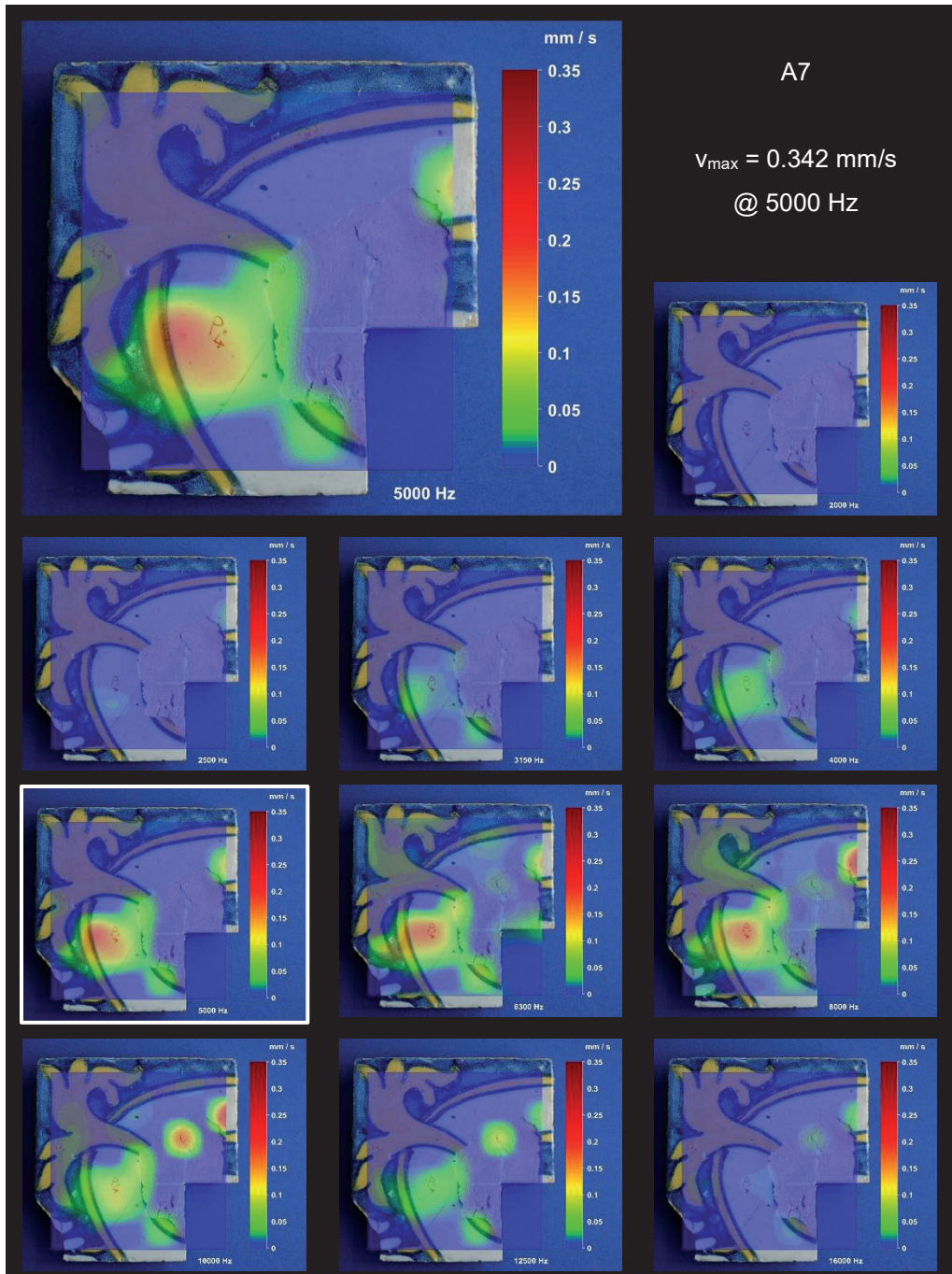


Figure 10: Vibro-acoustic images on A7, in the most significant frequency bands. The velocity peak falls in the 5000 Hz image, bordered in white and reproduced in wide format.

The evidences derived from the vibro-acoustic images are integrated by another comparative analysis of the samples. For the laboratory models, Figure 11 shows the function $v(f)$ acquired on the most representative points, i.e. the centre or the cavity's centre for T13, and allows us to examine the main features of these curves. Firstly, we notice the low T3 profile (black line) along with its proximity to the background level (grey line; it is obtained from a standard measurement on any point, without activating the acoustic excitation). The four models with cavities, displayed with coloured lines, present velocity peak values two orders of magnitude higher than the T3 level. Finally, we observe the expected shift of the main velocity peak towards higher frequency values as the cavity depth decreases, according to Equation 1, and already evidenced in the vibro-acoustic images of the four models.

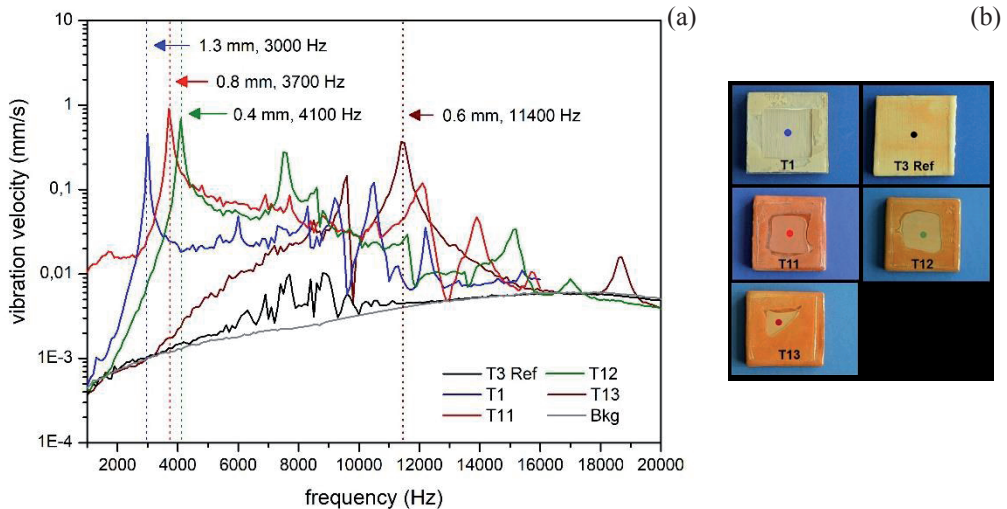


Figure 11: Comparison of the vibration velocity (a) corresponding to the most representative points of the five laboratory models (b). The nominal values of the cavity thickness and the measured frequency of the main peaks are also indicated for each model.

Regarding the two azulejos, we notice in Figure 9 the absence of relevant vibrations in A1 in all frequency bands, except in a relatively high frequency band (10 kHz). The sample A1 does not present any other relevant feature, although the light vibration evidenced in the 10 kHz image denotes the presence of a thin delamination and suggests the potential effect of an incipient decay process. For the purposes of this study, A1 still constitutes a *good reference* in the comparison with A7, although not a *perfect reference* (i.e. zero/negligible vibrations in all analysed frequency bands). Conversely, the sample A7 presents a number of critical areas, shown in Figure 10: despite the equal probability that the delamination progresses all around the lacuna's perimeter, the images indicate that the decay process is mainly advancing in the third quadrant, at the bottom-left sector of the tile, with another critical point in the first quadrant along the narrow stripe near the upper-right border.

As for the laboratory models, the function $v(f)$ acquired on the most representative points of the two azulejo samples are shown in Figure 12. Due to the irregular shape of the delaminated areas, the A7 curves do not present any narrow peak, but more irregular profiles. Also in this case two orders of magnitude separate the A7 curves from the A1 curve, except at 10400 Hz where the narrow peak of A1 reaches a significant value.

Considering all these aspects, in real cases a vibration in the high frequency bands can be reasonably ascribed to very thin cavities due to early stage delamination process, as for the sample

A1. A vibration in the low frequency bands can be related to severe damage and relatively thick cavities; in this case, higher modes of vibration should also be visible in the images corresponding to the multiple frequency bands, as for the sample A7. It follows that the method seems a useful tool for following the evolution of the decay process, from early stage to advanced decay. This task can be done:

- at a specific time, analysing the complete set of images looking for vibrations visible only at high frequency (*early stage decay*), and those spreading at low frequency (*advanced decay*);
- over a suitable period of time, periodically repeating the experimental test on the same area looking for significant changes: the widening of an existing delamination, or the enhancement of its thickness indicated by the main velocity peak shifting towards lower frequency values, according to Equation 1.

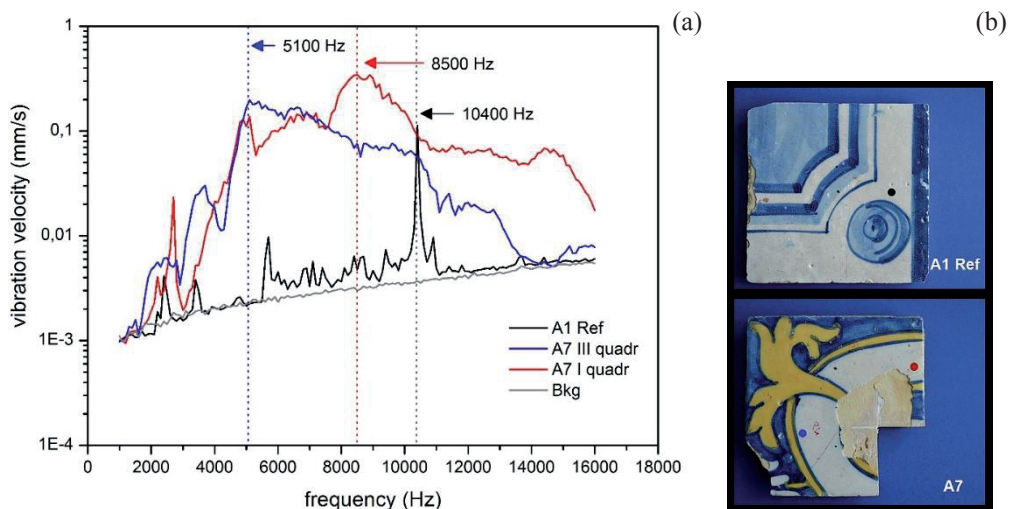


Figure 12: Comparison of the vibration velocity (a) corresponding to the most representative points of the two azulejo samples (b). The frequency of the velocity peaks are indicated.

Finally, the relevant parameters characterizing the seven samples and their behaviour are schematically reported in Table 3.

Table 3: Characteristic quantities relative to the samples and their behaviour.

ID	VELOCITY PEAK	FREQUENCY	CAVITY DEPTH
T3 Ref	0.038 mm/s	8900 Hz	
T1	0.337 mm/s	3000 Hz	square 1.3 mm
T11	0.667 mm/s	3700 Hz	square 0.8 mm
T12	0.537 mm/s	4100 Hz	square 0.4 mm
T13	0.348 mm/s	11400 Hz	triangular 0.6 mm
A1 Ref	0.116 mm/s	10400 Hz	
A7	0.195 mm/s; 0.342 mm/s	5100 Hz; 8500 Hz	

CONCLUSION

The proposed imaging method based on Laser Doppler Vibrometry was validated on laboratory models, simulating the physical response of real glazed tiles, and on historical Portuguese azulejos. Four laboratory models were purposely manufactured with artificial air cavities of different shape and depth, ranging from 0.4 mm to 1.3 mm, while a reference model was prepared without any cavity. The experimental results provide a clear picture of the cavities vibration induced by the acoustic excitation. The cavities were correctly localized, and characterized in relation to their shape and thickness showing the enhancement of the vibration frequency as the cavity thickness decreases. Additionally, the results obtained on the historical azulejos confirmed the localization of a significant delamination in one sample, while disclosing an unexpected vibration at high frequency in the second sample. Although the appearance of this second antique azulejo suggests a state of integrity, the instrumental analysis calls the attention to a potential decay process at an early stage of development. Thus the two azulejo samples seem positioned at two different stages of the glaze delamination process: one at an advanced stage with visible glaze loss, and the other at an incipient stage invisible to the naked eye.

The opportunity to detect hidden glaze delaminations a few hundreds of microns deep opens up new questions concerning both technical and theoretical issues. One issue regards the meaning of *early detection* in terms of *cavity depth*, corresponding to an initial phase of decay. The implications of this issue lead to other problems, for conservators-restorers and heritage scientists, related to the possible interventions on the asset. If a starting delamination process is detected, the subsequent issue regards the best conservation actions aiming to prevent its progression or slow down its rate of development. Other questions concern the integration of this knowledge with other information, within sustainable monitoring solutions.

Actually, the laboratory analysis realized for the present investigation can be also carried out onsite on extended surfaces, on real azulejo panels, with the enhancement of its benefit. Despite the powerfulness of the LDV due to its high spatial resolution and the non-invasiveness, some drawbacks concern the relatively high cost, the need for highly accurate device-target alignment and for expert operators. Further efforts are required to move towards simpler and low-cost configurations to plan more sustainable preventive conservation. The present study constitutes an important knowledge base also for the implementation of other and low-cost technique, such as the acoustical imaging method based on the acoustic energy absorption evaluation, developed by the same authors, already employed in explorative studies on glazed ceramic tiles.

Some final considerations lead us to recognize the most effective use of this diagnostic tool during the phase when the potential decay effect on the heritage asset is still little, and no-loss or modest modest loss of glaze is occurred. This is widely true for those heritage assets, like painted glazed ceramics, for which the preservation of their tangible integrity and authenticity are a pre-requisite for the acknowledgement of their outstanding value.

Bibliographic references

- ¹ *The NARA Document on Authenticity*, 1994. <https://www.icomos.org/en/179-articles-en-francais/ressources/charters-and-standards/386-the-nara-document-on-authenticity-1994> (accessed 12.07.18).
- ² *The Burra Charter: The Australia ICOMOS Charter for Places of Cultural Significance*, 2013. <https://australia.icomos.org/wp-content/uploads/The-Burra-Charter-2013-Adopted-31.10.2013.pdf> (accessed 10.10.2018).
- ³ MICHALSKI, Stefan, PEDERSOLI, José Luiz Jr. - *The ABC Method: a risk management approach to the preservation of cultural heritage*. Canadian Conservation Institute, Ottawa, 2016.

http://publications.gc.ca/collections/collection_2017/pch/CH44-157-2016-eng.pdf (accessed 12.07.18). ISBN 978-0-660-04134-6.

⁴ MIMOSO, João Manuel, PEREIRA, Silvia, SILVA, António Santos - *A research on manufacturing defects and decay by glaze loss in portuguese azulejos*. Relatório LNEC 24/2011. LNEC, Lisbon, 2011.

⁵ CALICCHIA, Paola, TRIVELLI, Renan, DE SIMONE, Sara, DI MARCOBERARDINO, Lucilla, VERARDI, Patrizio - *Non destructive evaluation of glaze delaminations in glazed ceramic tiles: laboratory tests*. In Proc. of the International Conference Glazed Ceramics in Architectural Heritage - GlazeArch2015, LNEC – Lisbon, 2015, 133-152.

⁶ ROTHBERG, S.J., ALLEN, M.S., CASTELLINI, P. et al. - *An international review of laser Doppler vibrometry: Making light work of vibration measurement*. Optics and Lasers in Engineering, 99, 2017, 11-22.

⁷ CASTELLINI, Paolo, ESPOSITO, Enrico et al. *New applications of Scanning Laser Doppler Vibrometry (SLDV) to non-destructive diagnostics of artworks: mosaics, ceramics, inlaid wood and easel painting*. Journal of Cultural Heritage Volume 4, Supplement 1, 2003, 321-329.

⁸ KINSLER, L.E., FREY, A.R., COPPENS, A.B., SANDERS, J.V. - *Fundamentals of Acoustics*, Wiley India Pvt. Limited, 2009. ISBN: 0471847895.

⁹ FANTUZZI, Nicholas, TORNABENE, Francesco, VIOLA, Erasmo - *Generalized Differential Quadrature Finite Element Method for vibration analysis of arbitrarily shaped membranes*. International Journal of Mechanical Sciences, 79, 2014, 216-251.

¹⁰ A simple description to the principles of Laser Doppler Vibrometry can be found in the Polytec website:

[https://www.polytec.com/eu/vibrometry/technology/\\$laser-doppler-vibrometry/](https://www.polytec.com/eu/vibrometry/technology/$laser-doppler-vibrometry/) (accessed 12.07.18).

¹¹ SCHOTT D 263[®] LA eco thin glass (LA = low-alpha) is a colorless borosilicate glass. It is available on the market in thicknesses ranging from 0.1 mm to 1.3 mm, and presents a number of advantages such as some physical properties similar to ceramics and it's easy to cut. More details are available on the website:

https://www.schott.com/advanced_optics/english/products/optical-materials/thin-glass/thin-glass-d-263-la-eco/index.html (accessed 12.07.18).

The implementation of computer-match pigment selection for overcoming metamerism in ceramic glaze reinstatement

Norman H. Tennent

University of Texas, Dallas, USA, normantennent@yahoo.co.uk

Holly V. Daws

West Dean College, West Dean, UK, s16hd@westdean.org.uk

Isabelle Garachon

Rijksmuseum, Amsterdam, NL, i.garachon@rijksmuseum.nl

James H. Nobbs

Colour4Free, Leeds, UK, james.nobbs@gmail.com

Mandy Slager

Restauratieatelier Mandy Slager, Leiden, NL, mslager@conservering.nl

Bouke J. de Vries

De Vries Conservation, London, UK, bouke@boukedevries.com

SUMMARY: This contribution concerns research conducted to assess the use of computer-match pigment selection (CMPS) in order to overcome illuminant metamerism. During the reinstatement of missing glazes, metamerism is a common troublesome feature faced by ceramic conservators. The colour of restored glaze areas (predominantly those with blue hues), in-painted using pigment mixtures in a polymer medium, often matches the original glaze under the lighting of the conservation studio but appears different in other lighting conditions. Previous research has demonstrated the potential of CMPS to provide non-metameric pigment combinations which match the original glazes for all light sources but the implementation of this in practice has necessitated further experimentation in conjunction with conservators.

The resultant research findings centre on the evaluation of a range of CMPS matching recipes for two blue standards, carried out by four ceramics conservators. The blue standards consisted of a monochrome blue glazed tile and a glossy blue paint sample from a commercial paint company's swatch colour fan. The results reported cover:

- *the ease of achieving a good colour match from the CMPS recipe pigment percentages,*
- *comparisons of the CMPS colour matches with corresponding results using conservators' own pigment choices,*
- *the potentiality for selection of a small palette of the most suitable pigments for non-metameric matches of blue ceramic glazes,*
- *the factors which need further development to facilitate implementation of the CMPS approach for glaze restoration.*

KEY-WORDS: metamerism, colour-matching, in-painting, blue glazes

INTRODUCTION

Although the principles and usefulness of computer-match pigment selection (CMPS) for ceramic glazed restoration have been described in previous publications [1,2], the success of CMPS relies on the ability of conservators to implement the approach routinely. Ease of implementation depends on several issues, all of which were explored in a Dutch research project, *Delftglaze* [3]. This project combined experimentation by ceramics conservators with relevant support from conservation and colour scientists in order to investigate the following topics:

- methods for measurement of reflectance spectra of ceramic glazes,
- the consistency of reflectance spectral data obtained by different instruments,
- the ease of sharing reflectance spectral data transmitted between researchers using the internet,
- the refinement of the CMPS software,
- the ease by which conservators can achieve good visual replication of ceramic glazes by means of pigment recipes suggested by the CMPS software.

In this paper, only the last of these topics is addressed in a bid to advance our long-term goal, namely to provide ceramic conservators with widespread and easy access to the benefits of CMPS and in so doing to render obsolete concerns about metamerism for ceramic glaze restoration. In order to accomplish this it has been necessary for the research to focus only on one essential component of an ideal pigment/polymer glaze restoration, namely that the hue of the restored area matches that of the glaze in all lighting conditions (i.e. does not suffer from illuminant metamerism).

In this context, it is important to stress that, in order to achieve a perfectly matching glaze restoration using pigmented polymers, ceramic conservators must replicate not only the hue but also the depth of shade, lightness, translucency, gloss and other features of the original fired glaze. To achieve success in matching all of these prerequisites requires conservation skills developed through extensive experience. For a full appreciation and scientific understanding of the relevant descriptive terms of visual appearance the monograph by Johnston-Feller [4] is invaluable, especially when supplemented by two more recent texts [5,6] which in combination successfully demystify the complexities of colour science.

In relation to the present research, it is of interest that, from the practitioner's point of view, the colorimetric terms describing colour differences dL^* , dH^* , dC^* - differences in lightness (lighter/darker), hue (redder/yellower/greener/bluer) and chroma (stronger/weaker) - are supplemented by workers in the paint, printing and dyeing industries by other descriptive terms with a more immediate relevance to the achievement of coloration in practice. These terms include the dyeing descriptors 'fuller/thinner' in place of stronger/weaker and the corresponding terms 'more or less pigmented' in the paint and printing fields. Associated industrial colorists' terms include the designation 'cleaner/dirtier' which reflects the notion of the effect of changing the colorimetric terms L^* and C^* simultaneously. The theoretical relationships between these terms have been described [7,8].

In the research described below, we are particularly concerned with variations in hue, dH^* , the colorimetric term primarily associated with metamerism. In the experimental testing of the non-metameric pigment recipes generated by the CMPS computer program, the team's conservators focused on achieving a matching hue and were less concerned with optimising the lightness, L^* , and chroma, C^* , as well as the other features such as translucency which are essential for optimal glaze reinstatement.

For glaze reintegration, ceramic conservators used a wide palette of pigments and individual pigment choices are very much a matter of personal preference. In conjunction with these colorants, a small range of polymers, notably acrylic and epoxy resins, are used as suitable glazing or filling mediums into which the colorant is blended. For health and safety reasons, acrylic aqueous emulsions are currently favoured over solvent-based systems and in recent years the availability of pigmented commercial retouching glazes avoids the necessity for conservators to blend dry pigments with a clear polymer glazing medium.

Within this framework, an experienced ceramic conservator can match the glaze appearance perfectly but has, unfortunately, no guaranteed control over one essential feature, namely that the match be non-metameric. Illuminant metamerism occurs when the in-painted zone matches the glaze hue in some but not all forms of illumination. Countless pigment combinations will match the glaze's hue perfectly in daylight, the most common illumination for restoration, but many of these combinations will be metameric.

The avoidance of metamerism is also important in other branches of conservation and has been most commonly addressed in publications with reference to easel paintings. This topic was well tackled by Staniforth in practice-oriented research which proposed suitable pigments for avoiding illuminant metamerism in painting restoration [9]. For ceramic restoration, the situation is more complex since conservators must use pigments to match not a paint layer but a fired glaze, with all the subtle variations in appearance that results from kiln glaze chemistry. No published information exists on pigments which achieve good non-metameric colour matching in ceramics conservation. Nonetheless, guaranteed avoidance of metamerism is possible in principle by the use of computer-match pigment selection, CMPS [1,2].

The CMPS methodology involves the measurement of the reflectance spectrum of the glaze in question and the selection of pigments from a computer database by means of specially-designed computer software which can predict the appearance of both the glaze and all possible matching pigment recipes under three diverse lighting conditions. The CMPS software selects non-metameric pigment recipes based on the three illuminant sources; D65 (daylight), F11 (fluorescent) and A (tungsten). The software judges the recipe to be non-metameric when, for each of the three illuminants, the overall colour difference (dE^*) is predicted to be low enough for a visual colour match to the standard.

EXPERIMENTAL

The assessment of ease of implementation of CMPS recipes focused on two different blue samples. Firstly, in order to provide a challenging test for the CMPS colour-matching trials, a monochrome tile was chosen with what was considered to be a difficult-to-match glaze colour because of the purple tint of this blue. Since there were different fragments of the same tile, these could be distributed by mail to the conservators for matching. Secondly, a glossy swatch card sample from the Jotun paint company was selected in order to explore possibility of distributing easily-available, glaze-like, uniformly blue-coloured standard samples to many conservators in future colour matching trials. This sample nicely complemented the tile in that its printed blue colour was judged by the participating conservators as more easy to match.

Colour measurements were made using a handheld spectrophotometer. Colour measurements and pigment recipes were prepared by the team's colour scientist (JN) using the CMPS software. Four conservators (IG, MS, BdV, HD) were involved in making matches using the computer-generated recipes as well as those judged by eye using the pigments and binding mediums with which they were most familiar. Coordination of the testing programme was undertaken by NT. This collaboration thus involved a varied partnership of a colour scientist, a conservation scientist and four conservators, working in five locations in the United Kingdom

and the Netherlands. Discussions took place on a face-to-face basis and by Skype and e-mail communication, resulting in extremely fruitful exchanges over the issues discussed below. Throughout the many months of the study, these interactions gave rise to small revisions in the computer software to create a more helpful version of both the recipe print-out and the presentation of the relevant colorimetric parameters for the results of the trials.

Apparatus, computer software, and materials

The spectrophotometric measurements were made using an X-Rite SP68 integrating sphere portable spectrophotometer. Measurements, made with specular reflectance included and a 5mm aperture, were the average of three readings on 6 different spots of the painted patches and 3 different spots for the standards. Photography was undertaken with a Nikon D800 camera with 105mm Nikon macro lens, ISO 100, aperture f10 using Profoto flash units with light box diffusers. For each match, the standard and painted patch were photographed in one shot. All shots were supported by inclusion of a GretagMachbeth mini 24 colour checker.

The CMPS program and the colorant database with which it is associated have been previously described [1]. This database of colorants comprises dry pigments favoured by ceramic conservators as well as a selected set of colorants which had been previously tested for good lightfastness in epoxy resin [10]. The Cromophtal range used consists of pigments pre-dispersed as a paste in di-octylphthalate [10].

Three commercial polymer resins, all supplied for conservation-restoration, were used for preparation of the test paint matches, namely two acrylic polymer emulsions (Golden Porcelain Restoration Glaze and Rustins Quick-drying Water-borne Acrylic Ceramic Glaze) and one epoxy resin (Fynebond).

Preparation of CMPS recipes

The CMPS standard recipes were all prepared by the developer of the software (JN) using the X-Rite SP68 reflectance spectra of the monochrome blue tile and the blue Jotun RAL5010 blue swatch card shade. In order to explore the usefulness of different colorants in the database, several non-metameric CMPS recipes for each standard were produced for the conservators to use in the colour matching testing (Table 1).

Preparation of the matching paint patches

The CMPS recipe gives the precise relative weight percentages of the pigment which should be used to achieve a non-metameric match with the standard. Since it is extremely difficult to carry out precise weighings of the very small amounts of pigment needed to prepare a single batch of the mixture for an individual test, the following variations were evaluated: i) use of precisely weighed amounts (to 3 decimal places) of pigments, ii) use of a coloured pie chart to represent the required proportions of the pigments, iii) mixing the pigments by eye, using the conservators' colour-matching skills to achieve a good match. Additionally, for comparison with normal practice, a variant of iii) involved the conservators' usual range of pigments instead of the CMPS database pigments.

Table 1: Computer match pigment selection recipes (Matches 1, 2 and 4) and conservators' pigment recipes (Matches 3 and 5) for the monochrome tile and Jotun paint sample RAL5010.

Standard	Match	Recipe				
		Pigment A	Pigment B	Pigment C	Pigment D	Pigment E
Monochrome tile	1	Cromophtal Blue A3R (Ciba-Geigy)	Carbon Black	Orasol Red BL (Ciba-Geigy)		
Monochrome tile	2	Cromophtal Blue A3R (Ciba-Geigy)	Prussian Blue (Kremer)	Cromophtal Violet B (Ciba-Geigy)	Orasol Red 395 (Kremer)	Zinc White (Cornelissen)
Monochrome tile	3	Dark Ultramarine (Cornelissen)	Ultramarine Violet (Cornelissen)	Irgazine Ruby DPP (Kremer)	Titanium White (Kremer)	
Jotun paint RAL5010	4	Cromophtal Blue 4GNP (Ciba-Geigy)	Carbon Black	Cromophtal Violet B (Ciba-Geigy)		
Jotun paint RAL5010	5	Ultramarine Blue (Golden)	Cobalt Blue Turquoise Dark (Kremer)	Synthetic Indigo (Cornelissen)	Lemon Yellow (Cornelissen)	Titanium White (Golden)

Assessment of the quality of the painted matches

The closeness in hue between the standard and the painted pigment/polymer patch was assessed from spectrophotometric measurements made using the X-rite SP68 instrument. The various reflectance spectra are illustrated in Figures 1-5. Because the lightness was not a criterion that the conservators took pains to match, the measured reflectance spectra of the painted patches were mathematically adjusted so that they simulated the lightness value, L^* , of the standards. This simulation was made by a change in the relative thickness of the paint layer by means of a Lambert's law type of calculation. Figures 1-5 depict these adjusted spectra and the parameters in Table 2 are derived from these spectra. The CMPS software enables colorimetric parameters for three standard illuminants (D65, A and F11) to be derived from the spectral reflectance measurements, thereby enabling the quality of the conservators' trial paint formulations to be compared to the standard in all three lighting conditions.

There are several different methods of producing a metamerism index (MI), i.e. a numerical quantification of illuminant metamerism [11]. As well described by Badcock [12], equations and methods of assessing metamerism have been produced based on two approaches, either on the colour differences of the samples under different light sources or on the differences in the reflectance curves of the pair of samples. The present conservation research has the aim to assess the success of the trial paint patches in avoiding metamerism. We have chosen to quantify this, not by a conventional MI but, more straight-forwardly, by the value of the difference in hue, dH^* , between the standard and the painted patch for each of the three illuminants.

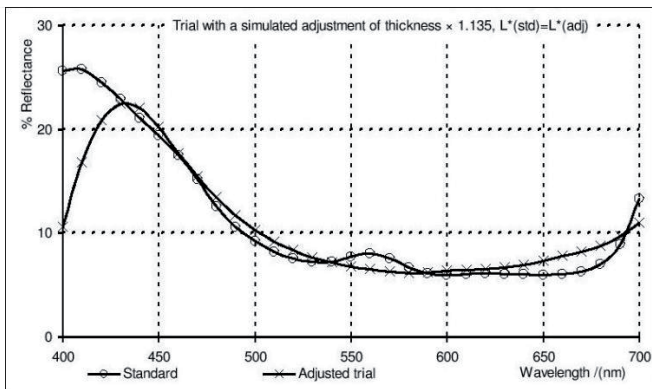


Figure 1: Reflectance spectra for the monochrome tile and pigment match 1, adjusted to a uniform lightness for the standard and the conservator's matching paint.

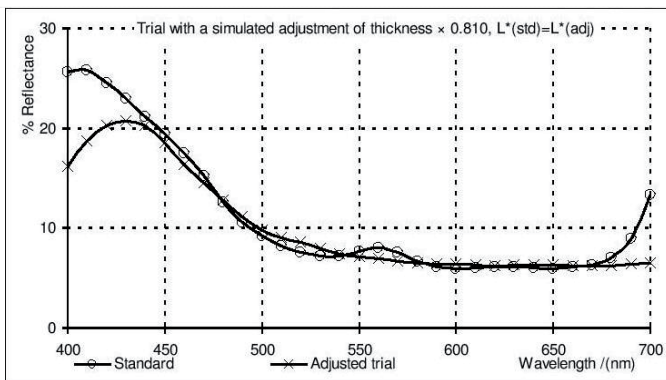


Figure 2: Reflectance spectra for the monochrome tile and pigment match 2, adjusted to a uniform lightness for the standard and the conservator's matching paint.

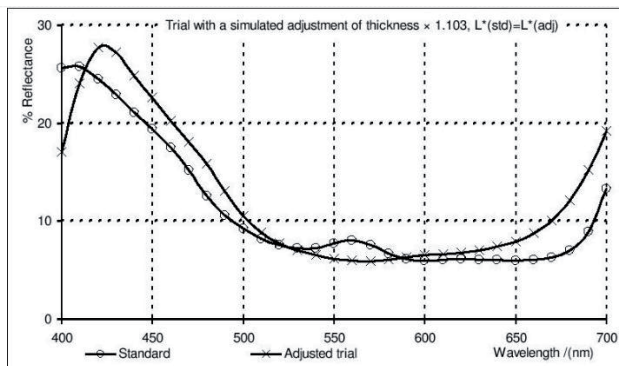


Figure 3: Reflectance spectra for the monochrome tile and pigment match 3, adjusted to a uniform lightness for the standard and the conservator's matching paint.

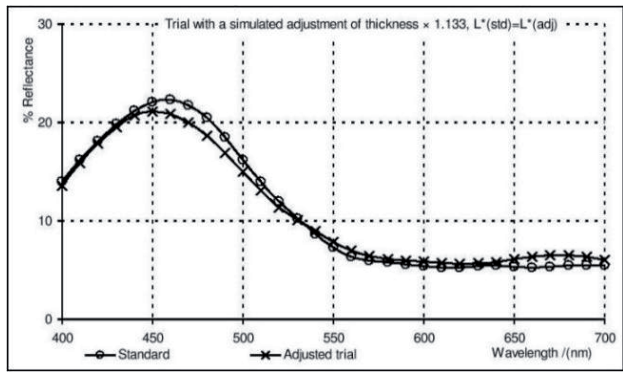


Figure 4: Reflectance spectra for the Jotun paint sample RAL5010 and pigment match 4, adjusted to a uniform lightness for the standard and the conservator’s matching paint.

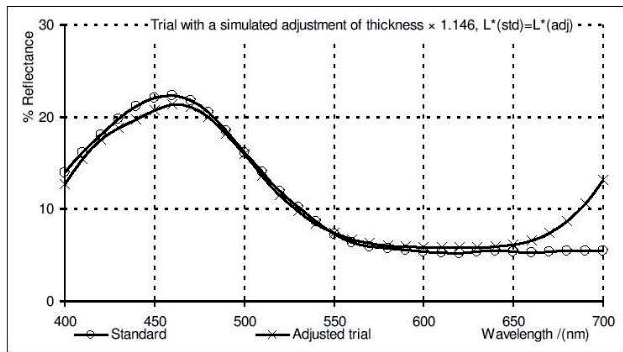


Figure 5: Reflectance spectra for the Jotun paint sample RAL5010 and pigment match 5, adjusted to a uniform lightness for the standard and the conservator’s matching paint.

Table 2 L^* a^* b^* (D_{65} , 10°) and dH^* values for conservators’ paint matches for the two standards; the monochrome tile and Jotun paint sample RAL5010. $dH^*(max)$ and $dH^*(min)$ represent the maximum and minimum differences in hue between the standard and paint match under illuminants D_{65} , A and F_{11} . $dH^*(D_{65})$ is the difference in hue between the standard and paint match under illuminant D_{65} .

Samples/Match	L^*	a^*	b^*	$dH^*(max)$	$dH^*(D_{65})$	$dH^*(min)$
Monochrome tile, match 1	34.03	8.67	-27.59	1.07, A	-0.74, D65	0.49, F11
Monochrome tile, match 2	34.03	6.65	-25.13	-1.97, D65	-1.97, D65	-0.57, F11
Monochrome tile, match 3	34.03	13.73	-33.66	4.12, A	1.89, D65	1.89, D65
Jotun paint sample RAL5010, match 4	36.78	-2.83	-25.27	1.32, D65	1.32, D65	0.68, F11
Jotun paint sample RAL5010, match 5	36.78	-3.51	-25.27	1.46, A	0.62, D65	0.39, F11

Table 2 reports $dH^*(\max)$, the maximum difference in hue from the standard. Also listed in this column is the illuminant with which that value is associated. In the final column of Table 2, $dH^*(\min)$ is reported to indicate the closest match in hue between the standard and the painted patch along with the illuminant that gives rise to this.

RESULTS AND DISCUSSION

The results reported represent a relatively small but representative sub-set of the pigment recipes derived for the two blue standards and the many conservators' attempts to match the colour of the standards with these CMPS recipes and with their own pigment choices. This sub-set of results allows attention to be focused on the main conclusions arising from the testing campaign's primary goal; to evaluate the success and the ease of implementation of the CMPS recipes by a range of conservators with different backgrounds and experience, in comparison to the pigments they normally use for colour matching during glaze reintegration.

The reflectance spectra in Figures 1-5 illustrate the painted patch matches for the two standards; the monochrome tile, Figures 1-3, and the Jotun commercial paint sample, Figures 4,5. (The corresponding pigments in the five recipes are given in Table 1.) These spectra provided the reflectance data from which the colorimetric parameters in Table 2 were derived using the CMPS software.

In no case is there a perfect overlap between the reflectance spectrum of the standard and that of the matching painted patch but the pair of spectra in Figure 4 match very closely indeed. The similar pair in Figure 5 also match exceedingly well throughout most of the visible spectrum but display a significant mismatch at the red end of the spectrum, above 650nm. Table 2 reports the corresponding numerical values which can be used to gauge the quality of the match and the tendency to display illuminant metamerism for the standard *vs* each painted patch. For the former pair, the maximum difference in hue, $dH^*(\max)$, is 1.32 whereas $dH^*(\max)$ for the latter pair is 1.46. Both pairs can be considered as good non-metameric matches. The first was prepared using a CMPS recipe, the second with the conservators' own choice of pigments. The appearance of these matches is illustrated in the photographic comparisons of Figures 6E and 6F.

In contrast, the corresponding $dH^*(\max)$ parameters for the monochrome tile matches in Figures 1 and 3 demonstrate the not only the value of CMPS but also the highly metameric results that can occur with conservators' own pigment matches. These matches were prepared by the same conservator. Match 3 utilised personal-choice pigments whereas for Match 1 the CMPS recipe was used. In both cases the pigment blends were gauged by eye. The respective $dH^*(\max)$ values were 4.12 and 1.07. The very discordant appearance of the Match 3 in tungsten light and the acceptable appearance of the same match in daylight are illustrated in Figures 6C and 6D.

The monochrome tile Match 2, prepared with a different CMPS pigment recipe by a different conservator, also displayed an acceptable, though rather less good, hue match under all three lighting conditions, with a $dH^*(\max)$ value of -1.97 in daylight (see Figure 6B).

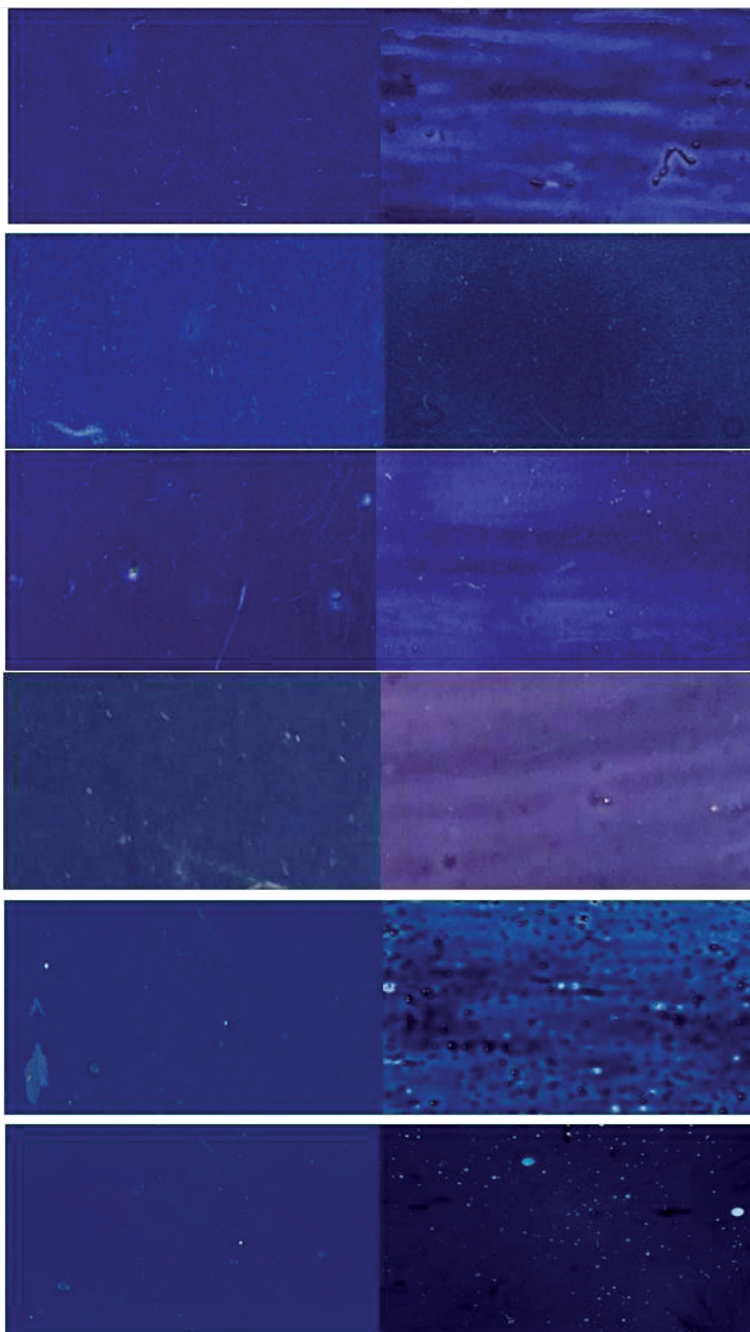


Figure 6: Photographic comparisons of the standards and paint matches. From top to bottom: A. Monochrome tile and pigment match 1 in daylight. B. Monochrome tile and pigment match 2 in daylight. C. Monochrome tile and pigment match 3 in daylight. D. Monochrome tile and pigment match 3 in tungsten light. E. Jotun paint sample RAL5010 and pigment match 4 in daylight. F. Jotun paint sample RAL5010 and pigment match 5 in daylight.

CONCLUSIONS

The conclusions from the four conservators involved in the trial was that CMPS offers a valuable means to achieve close, non-metameric matches in hue to the standards. A helpful feature is the restriction of the recipe to a small number of pigments which modify the hue of the selected principal blue component. However, implementation of the CMPS recipes was not totally straight-forward, partly because the team's conservators were unfamiliar with some of the CMPS pigments and their working properties. For example, although the low reflectance at the red end of the visible spectrum make the Chromophthal blue pigments a very useful addition to ceramic conservators' palette of pigments, the pre-dispersed versions give very intense coloration thereby making it difficult to moderate their impact in achieving the correct matching blend of the computer-generated pigments. In addition, not all colorants in the database blend equally easily with currently-preferred acrylic emulsion retouching formulations. This database was set up before the general preference, as a result of health and safety considerations, for aqueous polymer emulsions. Complete dispersion, an essential factor for the success of the CMPS recipes, is less easily achieved with aqueous systems. In particular, Orasol red did not easily provide an immediate total coloration with the acrylic emulsions. Better dispersion was achieved with epoxy resin but, nonetheless, there was a tendency for the recipes mixed by weight to be deficient in the red component. This was less troublesome when the conservators used their colour matching experience to gauge the ratios of the CMPS pigments. It was a general conclusion that the final hue was most accurately reached by small modifications, judged by eye, of the initial blend of the CMPS pigments based on the precise percentages given in the CMPS recipe.

Since the main weakness in ease of implementation of the CMPS methodology is associated with the measurement and blending of the pigment recipe, future research will focus on minimising these difficulties by means of especially pre-mixed pigment/polymer medium blends for a restricted set of database pigments of optimal usefulness.

Acknowledgement

The authors are grateful to Jim Dunn for photography.

Bibliographic references

1. TENNENT, Norman, NOBBS, James, BINNS, Malcolm and LAWTON Samuel, *The use of computer-match colour prediction in the restoration of ceramics*, In Preprints of ICOM-CC 14th Triennial Meeting, The Hague, 2005, 146-153
2. TENNENT, Norman, NOBBS, James, LAWTON Samuel and PUGH Samantha, *Developments in colour measurement for the restoration of blue and white Dutch tiles*, In Couleur & Temps. La Couleur en Conservation et Restauration, Preprints, SFIC Meeting, Paris, 2006, 259-265
3. <http://www.nicas-research.nl>
4. JOHNSTON-FELLER, Ruth, *Color Science in the Examination of Museum Objects Nondestructive Procedures*, The Getty Conservation Institute, Los Angeles, 2001
5. BERNS, Roy, *Principles of Color Technology*, 3rd Edition, John Wiley & Sons, Inc, New York, 2000
6. BERNS, Roy, *Color Science and the Visual Arts: A Guide for Conservators, Curators, and the Curious*, Getty Publications, Los Angeles, 2016
7. SMITH, Ken, *Partitioning Colour Differences into Dyers' Components: The 'DBH' Model*, Coloration Technology, 123, 2007, 170-177
8. SMITH, Ken, *Colour-order systems, colour spaces, colour difference and colour scales*, In Colour Physics for Industry, 2nd Edition, Ed R. McDonald, Society of Dyers and Colorists, 1997, 163-166

9. STANIFORTH, Sarah, *Retouching and colour matching: the restorer and metamerism*, Studies in Conservation, 30, 1985, 101-111
10. TENNENT Norman, *Clear and Pigmented Epoxy Resins for Stained Glass Conservation: Light Ageing Studies*, Studies in Conservation, 24, 1979, 153-164
11. KUO, W G, and LUO, M R, *Methods for quantifying metamerism. Part 2- Instrumental methods*, JSDC, 112, 1996, 354-360
12. BADCOCK, Tracey, *Accuracy of metameric indices in relation to visual assessments*, JSDC, 108, 1992, 31-41

Biodeterioration of glazed tiles: case studies and novel laboratory-based approaches

Mathilda L. Coutinho

Research Unit VICARTE – Glass and Ceramics for the Arts, Faculdade de Ciências e Tecnologia, Universidade NOVA de Lisboa, Caparica, Portugal, mathildal@gmail.com

Ana Z. Miller

Instituto de Recursos Naturales y Agrobiología de Sevilla (IRNAS-CSIC), Seville, Spain, anamiller@irnas.csic.es

Maria Filomena Macedo

DCR (FCT-UNL) e Vicarte – Vidro e Cerâmica para Artes, Caparica, Portugal, mfmf@fct.unl.pt

SUMMARY: When Glazed wall tiles are exposed outdoors, biological colonization and consequently biodeterioration may occur. Due to the lack of knowledge on the biodeteriogens affecting these assets, the characterization of microbial communities growing on Portuguese glazed tiles from Pena National Palace (Sintra) and Casa da Pesca (Oeiras) was carried out by culture and molecular biology techniques. A laboratory-based colonization experiment was then designed based on the results obtained in the case studies. Bioreceptivity and biodeterioration patterns of glazed wall tile models produced in laboratory were evaluated. Finally, mitigation strategies were tested in the field, specifically on glazed tiles from Casa da Pesca. This work sums up and analyses the results obtained in the case studies and laboratory experiments previously published by the authors.

KEY-WORDS: glazed tiles, ceramic, microorganisms, biodeterioration and bioreceptivity

INTRODUCTION

Glazed wall tiles, in Portuguese designated as “azulejos”, are ceramic plaques usually covered by a vitreous coating (glaze). Glazed tiles are architectural ceramic materials which are employed as a facing over another building material. Besides other advantages, glazed tiles increase impermeability, cleanability and mechanical resistance of surfaces and have low maintenance cost. However, the application of tiles goes far beyond practical purposes; their aesthetic function has particular relevance which explains their artistic and historic value. The variety of colours, glosses and iconography of these ceramic elements make their usage associated with an aesthetic intention. Throughout history glazed tiles were applied worldwide. In Europe their application was more extensive in countries such as Portugal, Spain, Italy, France and Holland, being today considered important cultural heritage assets ^[1–3].

Living organisms can interact with the surface of inorganic building materials on which they develop, altering their physical and chemical properties ^[4,5]. These undesirable alterations, defined as biodeterioration can result in physical, chemical and aesthetical damages affecting the value of cultural heritage assets. The interaction between organisms and substrate are complex mechanical, physical and chemical processes, which often occur simultaneously. The general mechanisms of biodeterioration of some inorganic building materials, such as stone have been investigated by several authors ^[5–9]. However, little is known about ceramic biodeterioration in

comparison with stone biodeterioration. In fact, few studies have dealt with glazed tile biodeterioration, as shown in the literature review on biodiversity, biodeterioration and bioreceptivity of architectural ceramic materials [10].

Understanding the relation between material properties and biological colonization is a crucial aspect in order to determine how microbial colonization can be mitigated. Guillitte (1995) proposed the concept of “bioreceptivity” which is the ability of a substrate to be colonized by organisms based on its intrinsic properties: (i) primary bioreceptivity refers to colonization of new material based solely on its intrinsic properties, (ii) secondary bioreceptivity refers to the colonization ability after a substrate has undergone a process of ageing and (iii) tertiary bioreceptivity refers to the colonization after a substrate has been submitted to a conservation treatment [11]. Yet, bioreceptivity of glazed tiles with traditional composition had not been analysed.

In order to deepen the knowledge on glazed wall tile biodeterioration and to start answering some of the crucial questions, namely which microorganisms colonize tiles? How and to which extent are these microorganisms affecting the substrate? How can glazed wall tiles be protected from these deterioration agents? A multiphase approach was designed.

METHODOLOGICAL APPROACH

A multiphase approach was outlined in order to start answering the above mentioned questions (Fig. 1). First, biodeteriogens and biodeterioration patterns in real case studies were investigated to identify the microbial communities dwelling over glazed wall tiles and understand their impact on the tiles. Second, a laboratory biodeterioration and bioreceptivity experiment was carried out so as to determine the after-effect of microbial colonization on glazed tiles. Third, three commercial biocides and a TiO₂ nanoparticles treatment were tested on densely colonized majolica tiles from *Casa da Pesca* (Oeiras). The effectiveness was evaluated in terms of inactivation of the microorganisms and long-term effect.

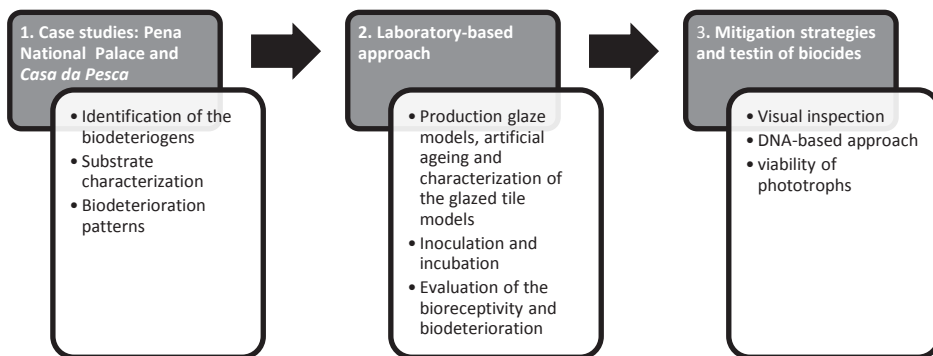


Fig. 1: Scheme of the methodological approach outlined to study glazed tile biodeterioration.

CASE STUDIES: PENA NACIONAL PALACE (SINTRA) AND CASA DA PESCA (OEIRAS)

Two monuments with tiles showing evident biological colonization were selected to be studied: Pena National Palace (Sintra, Portugal)^[12] and *Casa da Pesca* (Oeiras, Portugal)^[13]. Both the selected tile claddings presented dense microbial biofilms covering the tiles 'glazes' (Fig. 2).

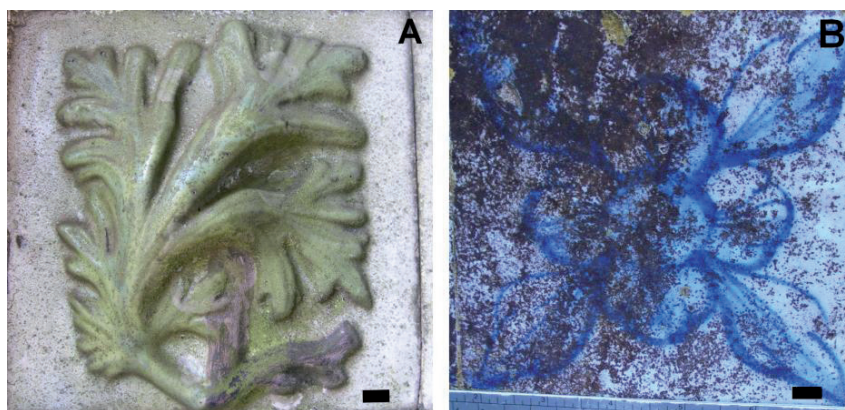


Fig. 2: Glazed tiles with biological colonization. Tile from Pena Nacional Palace with dark green microbial biofilme (A) and Tile from *Casa da Pesca* in Oeiras with dark dense microbial biofilm (B) (black line 1 cm).

The aesthetic biodeterioration caused by the development of these microbial biofilms on the tiles severely compromised its visual appreciation (Fig. 2). The historical tiles from Pena National Palace are located in the Triton tunnel being an unique example of nineteenth century glazed wall tiles attributed to the ceramist Wenceslau Cifka (Fig. 2A)^[14]. The ceramic wall tiles from *Casa da Pesca* (formerly a part of the Marquis de Pombal Palace) represent a more common typology of Portuguese glazed tiles (Fig. 2B).

Characterization of the microbial communities

A polyphasic approach, combining traditional culture and molecular biology methods was applied for microbial characterization. Currently, the characterization of the colonizing organisms is achieved combining: i) cultivation and classical taxonomy for identification of the culturable microorganisms and allows the identification of new species^[15] and molecular biology techniques widely applied in the field of cultural heritage for microbial diversity assessment, including non-culturable microorganisms^[16].

In both case studies the results revealed a biological patina consisting of fungi, microalgae, cyanobacteria and bacteria^[12,13]. The fungi composing the biofilms presented some resemblance. Actually, both biofilms had abundant dematiaceous fungi with brown hyphae. Many of these isolated fungal strains belonged to the same family, the recently described *Neodevriesiaceae* family that includes of the former *Devriesiaceae* family^[17]. In fact, the first described members of the *Devriesia* genus which are now part of the *Neodevriesiaceae* family were heat-resistant fungi isolated from heat treated soils^[18]. Indeed, glazed surfaces exposed to direct sunlight during hot seasons can achieve relatively high surface temperatures. The heat and drought resistance of these organisms and other rock-inhabiting fungi that can develop in desert areas could explain their ability to colonize glazed wall tiles.

In the case study regarding the Pena National Palace biofilm, some of the fungal strains that were isolated by culturing methods and grown in laboratory belonged to an unknown species. These fungal strains were later described and classified, as a new species named *Devriesia imbrexigena* A.J.L. Phillips & M.L. Coutinho [19]. Other fungi were also detected on the artistic tiles of the Pena National Palace, but only by DNA based methods which belonged to the phyla Ascomycota (*Capnobotryella* sp., *Stigmina* sp., *Capronia* sp., *Umbilicaria calvescens*, *Hortaea thailandica* and *Saccharata* sp.) and Basidiomycota (*Fellomyces sichuanensis* and *Kockovaella schimae*) [12].

The culture and DNA-based analyses of the biofilm from *Casa da Pesca* revealed the presence of fungi namely *Neodevriesiaceae* sp. 1. (close related to *Neodevriesia xanthorrhoeae*), *Devriesia modesta* and *Neodevriesiaceae* sp. 2. Only a minor proportion of the DNA sequences corresponded to unclassified *Ascomycota* from the *Capnodiales* order [13].

In general, the biodiversity of photoautotrophs in the biofilms collected from *Casa da Pesca* tiles [13] was lower in comparison to the microbial diversity detected on the glazed tiles from Pena National Palace [12]. According to Macedo et al. (2009) [20], environmental conditions and site-specific characteristics, such as solar irradiation, rain and wind exposure have a strong influence on the development of photosynthetic communities when compared with the substrate properties. The analyses of the biofilm from Pena National Palace revealed the presence of a high variety of phototrophic microorganisms belonging to Cyanobacteria (*Nostoc* sp., *Tolypothrix* sp. and *Chroococciopsis* sp.) and Green algae (*Oocystis solitaria*, *Chlorella saccharophila*, *Chlorella ellipsoidea*, *Apatococcus lobatus* and *Trentepohlia* sp.). In contrast, the phototrophic diversity was low in the brown biofilm from *Casa da Pesca*, which included the chlorophyta *Phycopeltis* sp. and the cyanobacterium *Iphinoe* sp.

Microscopy observations of the biofilm samples were also conducted, light microscopy of the biofilm samples from Pena National Palace tiles revealed the presence of species of green algae, which were not detected by molecular methods. A close interaction was observed between the *Trebouxia* cells with hyaline fungal hyphae (Fig. 3A), suggesting a lichen-forming process. However, no well-developed lichens were observed on the wall tiles. The dematiaceous fungi with brown hyphae which had similar morphologic features to the *Neodevriesiaceae* specimens identified by DNA-based analyses. These fungi were surrounding dead cells of green algae (Fig. 3A).

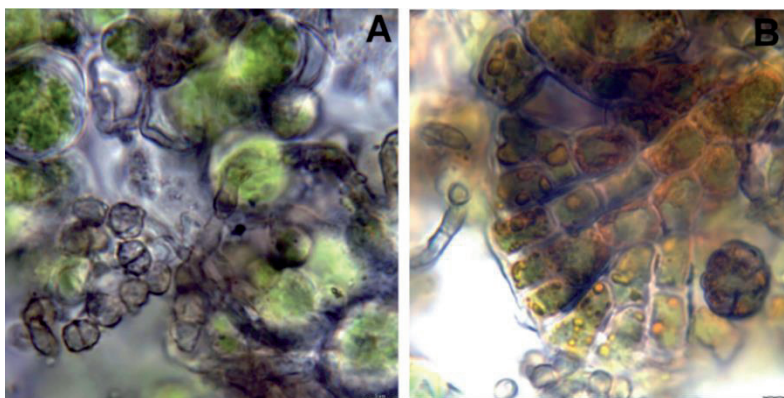


Fig. 3: Micrographs of the biofilm samples observed by light microscope. (A) Pena National Palace samples with dematiaceous fungi with brown hyphae and (B) *Casa da Pesca* samples with *Phycopeltis arundinacea* cells and brown hyphae of a dematiaceous fungi.

In the biofilm samples collected from the *Casa da Pesca* tiles, the green alga *Phycopeltis arundinacea* (Montage) De Toni ^[21,22] was observed in large quantities, as also detected by molecular biology methods. The *Phycopeltis arundinacea* cells were surrounded by dematiaceous fungi with brown hyphae (Fig 3.B). Although a close interaction between fungi and algae was observed, no lichens or lichenization process were identified in this biofilm^[13].

The direct microscopic observations of photosynthetic microorganisms and fungi allowed the recognition of pre-lichenization processes, interactions among microorganisms and an estimation of the organisms' proportion in the biofilm. Additionally, culture and molecular methods allowed the individual identification of the members of the biofilm. The three step methodological approach involving direct microscopy observations, culture and molecular methods provided an accurate identification of the tile colonizing microorganisms.

Biodeterioration Patterns

In both case studies not only dense colonization was observed over the glaze surface, but colonization also occurred within fissures (Fig. 4). The colonization within fissures, named chasmolithic colonization, may cause the disintegration of the substrate as a result of volume changes, penetration in the ceramic matrix and release of metabolic substances, such as organic and inorganic acids ^[23]. Although the observed colonization within fissures could be related with the flaking of the glaze observed on the wall tiles from Pena National Palace and Casa da Pesca, no conclusions can be drawn without further laboratory testing.

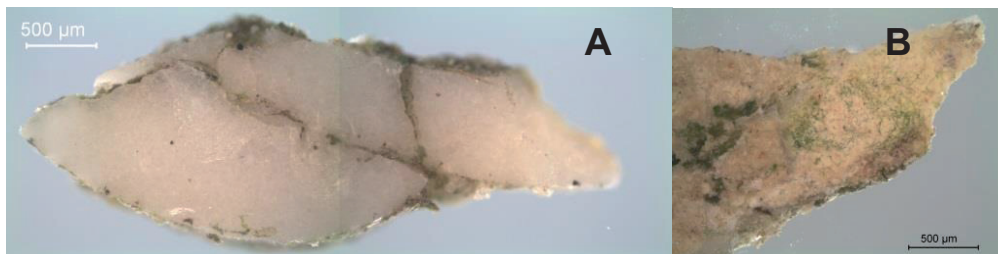


Fig. 4: Micrograph of a glaze sample from Pena National Palace. (A) glaze with colonization within the fissures. (B) under view of the same fragment with biological colonization in the ceramic body.

The high diversity of microorganisms on what seems to be an inhospitable substrate, such as lead-based glazed tiles, confirms the importance of understanding the relationship between substrate and microorganisms.

The analysed case studies demonstrated that the development of biofilms over glazed surfaces is influenced by specific environmental conditions, such as surrounding vegetation, shelter from rain, low solar irradiance (facing north) and surface relief. For both case studies, the walls facing south showed less colonization or even no colonization on the glazed tile surface.

LABORATORY-BASED EXPERIMENTS

To understand the role of phototrophic microorganisms and fungi on the deterioration of the majolica glazed tiles, the laboratory biodeterioration experiment was performed. New tile models were produced in laboratory and used as test substrate to assess the biodeteriogenic action of these microorganisms on the glazed tiles.

In the field of conservation sciences understanding how the conservation state influences bioreceptivity is extremely relevant. Therefore, half of the produced glazed tile models were artificially aged.

Tile Models

Glazed wall tiles models were produced in laboratory with a commercial ceramic paste (PF, SIO-2 CERÁMICA COLLET S.A., Spain) was kneaded manually, rolled-out and cut into squares (approximately 2.5x2.5 cm). At the center of each square a concentric circular depression was made to better sustain the microbial suspension that would be inoculated. After air-drying the ceramic body was fired at 950 °C (100 °C per hour and 1 hour dwell). The lead–tin majolica model glaze was prepared by adjusting the composition of the commercial frit TR29 (Ferro) and pure raw laboratory materials. The glaze was applied by pouring the raw glaze suspension over the dry ceramic body. After 24 hours air-drying tiles were fired at 980 °C (100 °C/h heating rate with 1 h dwell at 980 °C). The ageing to study the secondary bioreceptivity [11,24] was achieved by chemically corroded by immersion into alkaline NaOH solution (pH 10) during 10 days. Afterwards, the samples were rinsed with distilled water and air-dried. To simulate mechanical decay, the samples were submitted to thermal shock, though cycles (n=3) of heating (150 °C) during 20 minutes and directly followed by immersion into ice-cold water. A more detailed described is made in previous Coutinho et al. [25].

The chemical composition of the pristine and aged glaze is presented in Table 1 [25]. The characterization of tiles from Pena National Palace showed a glaze composition of an alkali-lead silicate glaze, commonly applied in the majolica production technique [26]. The main difference was related to the proportions of some oxides, namely Na₂O, K₂O and Al₂O₃.

Table 1: Chemical composition (wt. %) of the glaze analyzed by μ-PIXE in pristine (n = 3) and aged (n = 3) tile model samples. Mean values are presented together with the standard deviation (SD) and ANOVA results [25].

Oxides (wt. %)	Pristine (mean ± SD)	Artificial/Aged (mean ± SD)
Na ₂ O	0.3 ± 0.04	0.3 ± 0.06
MgO	0.4 ± 0.03	0.4 ± 0.01
Al ₂ O ₃	3.4 ± 0.30	3.2 ± 0.10
SiO ₂	47.0 ± 2.70	45.2 ± 5.20
Cl	0.1 ± 0.05	0.1 ± 0.10
K ₂ O	1.5 ± 0.10	1.3 ± 0.01
CaO	1.0 ± 0.08	1.1 ± 0.10
TiO ₂	0.1 ± 0.02	0.1 ± 0.01
Fe ₂ O ₃	0.2 ± 0.01	0.2 ± 0.03
SnO ₂	10.2 ± 0.10	10.0 ± 1.00
PbO	35.7 ± 2.50	38.0 ± 4.50

Values in the same row were not significantly different by the Tukey HDS test at p < 0.05.

The main intrinsic physical features, namely hydric properties viz. water absorption by capillarity and water vapor permeability, capillary coefficient and surface roughness (Ra), of the pristine and aged tile models are summarized in Table 2 [25].

Table 2: Average and standard deviation (\pm SD) of capillarity coefficient (Q), water vapour permeability coefficient (Δ) and surface roughness (Ra) of pristine ($n=3$) and aged ($n=3$) samples [25].

Model tile	Q (g.m-2.s-1/2)	Δ (Kg/m.h.Pa)	Ra (Å)
Pristine	1.3 \pm 1.4(a)	1.5 \times 10 ⁻¹⁰ \pm 4.6 \times 10 ⁻¹¹ (a)	12.6 \pm 3.2(a)
Artificial/Aged	10.8 \pm 6.1(a)	3.9 \times 10 ⁻¹⁰ \pm 1.3 \times 10 ⁻¹⁰ (b)	13.0 \pm 1.4(a)

Values followed by the same letters in brackets in the same column are not significantly different by the Tukey HDS test at $p < 0.05$.

The artificial ageing of the tile models promoted changes in the microfissures network[25]. Although the glaze is an impermeable coating, the presence of surface flaws, such as pitting or fissure network on the glaze results in some permeability even in the pristine glazes (Table 2). However, a higher density of microfissures and wider fissures were visible on the surface of the aged tile models due to the ageing process (Fig. 5). Consequently, the main differences in water permeability though the glazed surface of the pristine and aged tiles could be justified by the differences in the fissure network of the glazes.

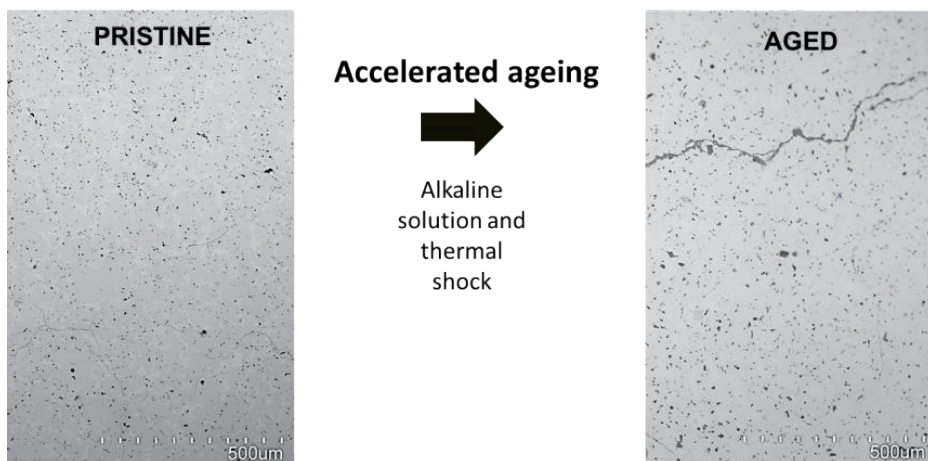


Fig. 5: Illustration of the pristine and aged tile models surface with an example of the micrograph of the surface obtained by SEM.

Inoculation of tile models

The biodeterioration and bioreceptivity experiment with the pristine and artificially aged glazed tile models was performed by inoculating half of the samples with a multi-species photoautotrophic culture (*Trentepohlia laginefera*, *Chlorella ellipsoideia*, *Apathococcus vulgaris*, *Nostoc microscopicum*) and another set of samples with an axenic culture of the fungus *D. imbrexigena*. This fungus was previously isolated from glazed tiles from Pena National Palace [19]. The experiment described in Coutinho et al. (2016) [25] was made with two sets of inoculated pristine and aged tile samples and a third set which was used for control samples without inoculation (Fig. 6). All samples (inoculated and control samples) were kept under the same laboratory environmental conditions (22–23 °C and 75–95% RH) during the incubation period (12 months).

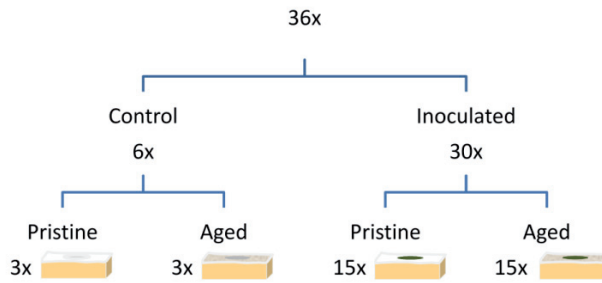


Fig. 6: Experimental design of the bioreceptivity and biodeterioration experiment

Post-experiment observations and results

For determining bioreceptivity it is necessary to quantify the extent of colonization. Growth of organisms was estimated by quantifying the extent of biofilm surface coverage area using digital image analysis, the chromacity by measuring the colour and calculating the biomass by measuring *chlorophyll* a fluorescence [25].

Results showed that the pristine tile samples inoculated with phototrophic microorganisms showed lower bioreceptivity than the aged tiles, as expected. Other studies with phototrophic microorganisms also concluded bioreceptivity can be correlated to properties related with water movements though the substrate [27]. For the samples inoculated with fungi, no significant differences could be detected regarding the bioreceptivity of the pristine and aged tiles. Considering that fungi are heterotrophic microorganisms, their development on inorganic substrates without any input of organic matter may have hinder their growth.

Scanning electron microscopy (SEM) observations showed dense microbial colonization growing over the glazed surfaces on both pristine and aged tiles samples. Regarding the experiment with phototrophic microorganisms, chasmoendolithic growth within glaze fissures was observed in both types of inoculated samples (Fig. 7).

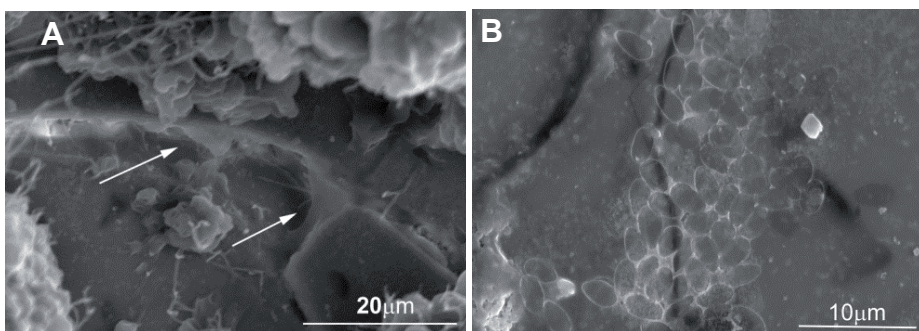


Fig. 7: SEM images of majolica tiles models after the biodeterioration experiment. (A) Growth of microorganisms within a fissure of a pristine model glaze with EPS indicated by arrows and (B) fingerprints of oval shaped cell on the glaze surface after removal of the biofilm.

The adhesion of phototrophic microorganisms by extracellular polymeric substances (EPS) to the glaze and their penetration into fissures was noteworthy (Fig. 7A). After the removal of the biofilms with cotton swabs soaked with a water-ethanol solution, imprints of rod-shaped cells were observed, indicating the etching of the glaze by the inoculated phototrophic microorganisms

(Fig. 7B). The chasmolithic growth and release of organic acids could lead to glaze detachment as observed on the tiles from Pena National Palace.

Regarding the fungi inoculated samples, no penetration was observed on the glaze fissures. However, calcium oxalate, a mineral of biological origin, was detected over the glaze surface on both pristine and aged samples. Fungi seemed to be less invasive colonizers; however the detection of oxalates indicated that this compound could chemically interact with the glaze substrate inducing chemical biodeterioration^[28].

The laboratory-based experiments demonstrated the damage potential of the tested microorganisms (Phototrophs and fungi) on the tile surfaces.

BIOCIDAL TREATMENTS ON THE MICROBIAL COMMUNITY FROM CASA DA PESCA




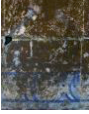
Four different treatments were tested in situ on the biofilms growing over the glazed wall tiles from Casa da Pesca^[13]. A photocatalyst compound, Titanium dioxide P25 nanocrystalline anatase (TiO₂) with a specific surface area of 50 m² g⁻¹ and particle size of approximately 20 nm (Degussa, Frankfurt, Germany), treatment was prepared in an aqueous suspension 1% (w/v), which was previously tested on an outdoor cultural heritage asset^[29]. The three commercial biocides, commonly applied conservation and restoration interventions of monuments were: i) Preventol[®] RI 80 (hereinafter Preventol), composed of alkyl-benzyl-dimethyl-ammonium chloride and isopropyl alcohol (Lanxess, Leverkusen, Germany); ii) Biotin[®]T (hereinafter Biotin), which contains alkyl-benzyl-dimethyl-ammonium chloride, octyl-isothiazolone and 3-iodo-2-propynyl-butylcarbamate (C.T.S., Spain), and iii) Albilex Biostat[®] (hereinafter Albilex), containing alkyl-benzyl-dimethyl-ammonium chloride and dihydroxide chromium (H₂Cr₂O₇) (2:1) (Albishausen, Usingen, Germany). All commercial biocides were applied using the concentrations specified in the manufactures' instructions: 2% (v/v) for Biotin, 2% (v/v) for Preventol and 1% (v/v) for Albilex. Each treatment was applied directly to 3 tiles with a paint-brush until soaking as previously described in Coutinho et al. (2016)^[13].

The evaluation of the efficacy of the biocides was based on several parameters: (i) the biofilm-covered area, colour and opacity of the biofilm to evaluate the efficacy in removing the biofilm from the tile surface; (ii) the microbial diversity before and after the biocide treatments to evaluate the effect of biocides on microbial community; and (iii) the viability of the photosynthetic components of the biofilm by monitoring the Chlorophyll a fluorescence by epifluorescence in order to monitor the biocidal effect.

Preventol was the most effective biocide against the detected microorganisms followed by Biotin at the concentration tested (Table 3). Both biocides had also as a result lowering the opacity of the biofilm which allowed to see the underlying drawing. However, the biofilm was not removed from the surface, a thin layer of biofilm debris continued attached to the glazed surface. Albilex seemed to have little or no effect on the microbial biofilm under the tested conditions. However, it must be highlighted that even the most efficient tested biocides showed no long term protection as recolonization by phototrophic microorganisms was detected 6 months after biocidal application both by DNA-based methods and by epifluorescence^[13]. These results are demonstrative of the limited time scale effect of the tested biocides. Lixiviation by rain and consequent decrease in concentration of Preventol and Biotin might have allowed the recolonization of the treated substrates by microorganisms.

The TiO₂ nanoparticles were not effective in the inactivation of the microorganisms, although their antimicrobial mechanisms have been recently described^[30]. However, TiO₂ had a physical action on the biofilm causing its detachment from the substrates without the aid of any mechanical method.

Table 3: Resume of the results obtained in the biocide experiment^[13].

Biocide	6 months	Visual inspection			Viability (Epifluorescence)		Microbial communities			Interaction with substrate (SEM)
		Visibility of underlying tile	Removal of biofilm	Longterm effects	4 months	6 months	Cyano-bacteria	Fungi	Algae	12 months
nano TiO ₂		•	***	***	*	•	•	•	•	•
Preventol		***	•	*	***	*	**	***	***	•
Biotin		**	•	*	***	*	***	**	**	•
Albalex		•	•	•	•	•	*	•	•	•

Degree of change: •-not detectable; *- few; **- significant and ***-drastic.

FINAL REMARKS

This work provides the first comprehensive approach on the bioreceptivity and biodeterioration of majolica glazed tiles combining field surveys (case studies) and laboratory-based experiments. Glazed tile biodeteriogens were identified in two cases studies (Pena National Palace and Casa da Pesca) and tile biodeterioration observed in colonized samples were reproduced under laboratory conditions.

An integrated approach of the complex microbial communities found on glazed wall tiles was achieved. Microscopy techniques combined with culture and molecular methods allowed the identification of the microorganisms forming the biofilms from Pena National Palace and *Casa da Pesca*, as well as the recognition of interactions among different microbial groups.

The primary bioreceptivity of tiles to phototrophic microorganism and fungi was evaluated on tile models produced in laboratory by inoculating them with a culture of phototrophic microorganism and an axenic culture of fungi, respectively. Secondary bioreceptivity to photoautotrophic colonization revealed that aged tile samples had higher bioreceptivity compared to pristine tiles, which was mainly due to the physical properties of the aged tile models, such as higher capillary coefficient and water vapour permeability coefficients. The evaluation of the primary and secondary bioreceptivity of glazed tiles to fungi showed no significant differences.

The laboratory-based biodeterioration experiments have demonstrated the damaging potential of phototrophic microorganisms on glazed wall tiles. The most evident change of the tested microorganisms was physical due to the chasmoendolithic growth on fissures. This might led to physical damage on the substrate, like the deterioration patterns observed in Pena National Palace. In contrast, fungi were not able to cause physical damage on the substrate, but their exudates, particularly oxalic acid was able to react with calcium leading to formation of calcium oxalate.

The cleaning and inactivation of a biofilm is a complex issue, since the inactivation of microorganisms depends on several factors. Our data on the *in situ* application of biocides on

colonized wall tiles from *Casa da Pesca* revealed that the most efficient tested biocides (Preventol RI 80 and Biotin T) showed no long term efficiency. However, the combined application of TiO₂ nanoparticles would represent a promising strategy for biofilm removal as this photocatalyst compound caused the detachment of the biofilms without the aid of any mechanical method.

Acknowledgements

Monte da Lua, S.A. and Estação Agronómica Nacional – INIAV are acknowledged. This study was supported by *Fundação para a Ciência e a Tecnologia* (FCT) under the Vicarte project UID/EAT/00729/2013 and doctoral grant no. SFRH/BD/46038/2008.

Bibliographic references

- [1] VAN LEMMEN, H. - *Tiles 1,000 Years of Architectural Decoration*, Harry N. Abrams, New York, 1993.
- [2] BERENDSE, A., KEEZER, M. B., SCHOUBYE, S., SANTOS SIMÕES, J. M., TICHELAAAR, J. - *Tiles a general history*, Faber and Faber, London, 1967.
- [3] BANDINI, G., LE BRETON, J.-M., ROSSILLON, P., MECO, J., BALANDA, É., URIBE ECHEVERRÍA, A. - *Les metamorphoses de l'azur, l'art de l'azulejo dans le monde latin, ars latina*, Paris, 2002.
- [4] HUECK, H.J. - *The Biodeterioration of Materials as Part of Hylobiology* MaterOrg 1, 1965, 5–34.
- [5] WARSCHEID, T., BRAAMS, J. - *Biodeterioration of stone: a review*. International Biodeterioration & Biodegradation 46, 2000, 343.
- [6] KUMAR, R., KUMAR, A. *Biodeteriogens: Characteristics and Biodeterioration Mechanisms*. In: Biodeterioration of stone in tropical environments an overview A. S. Agnew N, Berland D (Eds), The getty conservation institute, Los Angelos, 1999, 12–32.
- [7] SAND, W. - *Microbial Mechanisms of Deterioration of Inorganic Substrates_A general Mechanistic Overview* International Biodeterioration & Biodegradation 40, 1997, 183.
- [8] PINNA, D., SALVADORI, O. - *Processes of biodeterioration general mechanisms In Plant biology for cultural heritage*. Biodeterioration and conservation, G. Caneva, M. P. Nugari, O. Salvadori (Eds), The getty conservation institute, Los Angeles, 2008, 15–34.
- [9] BADALYAN, A.G., GORBUSHINA, A.A., KRUMBEIN, W.E., KUZMEROV, Y.A., PANINA, L.K., and VLASOV D.Y. - *Physical and Microbiological Investigations of Rock Weathering at Hellenic Excavation Sites on the Crimean Peninsula*. In: Proceedings of the 8th International Congress on Deterioration and Conservation of Stone : Berlin, 1996 / Josef Riederer (Eds), vol. 1 1996, 671–79.
- [10] COUTINHO, M.L., MILLER, A.Z., MACEDO, M.F. - *Biological colonization and biodeterioration of architectural ceramic materials: An overview*. Journal of Cultural Heritage, 16, 2015. 759-777
- [11] GUILLITTE, O. - *Bioreceptivity: A New Concept for Building Ecology Studies*. Science of The Total Environment 167 (1–3) 1995, 215–20.
- [12] COUTINHO, M.L., MILLER, A.Z., GUTIERREZ-PATRICIO, S., HERNANDEZ-MARINE, M., GOMEZ-BOLEA, A., ROGERIO-CANDELERIA, M.A., PHILIPS, A.J.L., JURADO, V., SAIZ-JIMENEZ, C., MACEDO, M.F. - *Microbial communities on deteriorated artistic tiles from Pena National Palace (Sintra, Portugal)*. International Biodeterioration & Biodegradation 84, 2013, 322-332.

- [13] COUTINHO, M.L., MILLER, A.Z., MARTIN-SANCHEZ, P.M., MIRÃO, J., GOMEZ-BOLEA, A., MACHADO-MOREIRA, B., CERQUEIRA-ALVES, L., JURADO, V., SAIZ-JIMENEZ, C., LIMA, A., PHILLIPS, A.J.L., PINA, F., MACEDO, M.F. - *A multiproxy approach to evaluate biocidal treatments on biodeteriorated majolica glazed tiles*. Environmental Microbiology 18, 2016, 4794-4816.
- [14] COUTINHO, M.L., VEIGA, J. P., ALVES, L.C., MIRÃO, J., DIAS, L., LIMA, A. M., MURALHA, V.S., MACEDO, M. F. - *Characterization of the Glaze and In-Glaze Pigments of the Nineteenth-Century Relief Tiles from the Pena National Palace, Sintra, Portugal*. Applied Physics A 122 (7), 2016, 696.
- [15] OTLEWSKA, A., ADAMIAK, J., GUTAROWSKA, B. - *Application of Molecular Techniques for the Assessment of Microorganism Diversity on Cultural Heritage Objects*, Acta Biochimica Polonica 61 (2), 2014, 217–25.
- [16] DIAZ-HERRAIZ, M., Jurado, V., Cuezva, S., Laiz, L., Pallecchi, P., Tiano, P., Sanchez-Moral, S., Saiz-Jimenez, C. - *Deterioration of an Etruscan Tomb by Bacteria from the Order Rhizobiales*, Scientific Reports 4 2014, 3610.
- [17] QUAEDVLIEG, W., BINDER, M., GROENEWALD, J. Z. Z., SUMMERELL, B. A., CARNEGIE, A. J., BURGESS, T. I., CROUS, P. W. - *Introducing the Consolidated Species Concept to resolve species in the Teratosphaeriaceae*. Persoonia - Mol. Phylogeny Evol. Fungi 33, 2014, 1.
- [18] SEIFERT, K. A., ICKERSON, N. L., CORLETT, M., JACKSON, E. D., & LOUIS-SEIZE, G. - *Devriesia*, a new hyphomycete genus to accommodate heat-resistant, cladospore-like fungi. Canadian Journal of Botany 2004, 82, 914.
- [19] CROUS, P. W. W., SHIVAS, R. G. G., WINGFIELD, M. J. J., SUMMERELL, B. A. A., ROSSMAN, A. Y. Y., ALVES, J. L. L. ET AL. - *Fungal Planet description sheets: 128-153*. Persoonia 29, 2012, 146.
- [20] MACEDO, M. F., MILLER, A. Z., DIONÍSIO, A., SAIZ-JIMENEZ, C. - *Biodiversity of cyanobacteria and green algae on monuments in the Mediterranean Basin: an overview*. Microbiology 155, 2009, 3476-3490.
- [21] RINDI, F., & GUIRY, M. - *The genus Phycopeltis (Trentepohliaceae, Chlorophyta) in Ireland: a taxonomic and distributional reassessment*. Phycologia 41, 2002, 421.
- [22] RINDI, F., MENENDEZ, J. L., GUIRY, M. D., RICO, J. M., MENÉNDEZ, J. L., GUIRY, M. D., RICO, J. M. - *The taxonomy and distribution of Phycopeltis (Trentepohliaceae, Chlorophyta)*, Cryptogamic Algae, 25(1), 2004, 3–17.
- [23] GORBUSHINA A. A. - *Life on the rocks*, Environmental microbiology 2007, 9, 1613-31.
- [24] MILLER, A. Z., ROGERIO-CANDELERA, M.A., DIONÍSIO, A., SAIZ-JIMENEZ, C., MACEDO, M. F. - *Assessing the Influence of Surface Roughness on the Epilithic Colonisation of Limestones by Non-Contact Techniques*. Materiales de Construcción 62 (307), 2012, 411–24.
- [25] COUTINHO, M.L., MILLER, A.Z., ROGERIO-CANDELERA, M.A., MIRÃO, J., CERQUEIRA-ALVES, L., VEIGA, J.P., ÁGUAS, H., PEREIRA, S., A. Lyubchik, A., MACEDO, M.F. - *An Integrated Approach for Assessing the Bioreceptivity of Glazed Tiles to Phototrophic Microorganisms*. Biofouling 32 (3) 2016, 243–59.
- [26] TITE, M. S. - *The Production Technology of Italian Maiolica: A Reassessment*. Journal of Archaeological Science 36 (10). 2009, 2065–80.
- [27] MILLER, A.Z., SANMARTÍN, P., PEREIRA-PARDO, L., DIONÍSIO, A., SAIZ-JIMENEZ, C., MACEDO, M.F., PRIETO, B. - *Bioreceptivity of Building Stones: A Review*. Science of The Total Environment 426 2012, 1–12.

[28] COUTINHO, M.L., PHILLIPS, A.J.L., MILLER, A.Z., MARTIN-SANCHEZ, P.M., MIRÃO, J., DIAS, L., CERQUEIRA-ALVES, L., JURADO, V., SAIZ-JIMENEZ, C., PINA, F., MACEDO, M.F. - *Biodeterioration of Majolica Glazed Tiles by the Fungus Devriesia Imbrexigena*. Construction & Building Materials (Under revision).

[29] FONSECA, A.J., PINA, F., MACEDO, M. F., LEAL, N., ROMANOWSKA-DESKINS, A., LAIZ, L., GÓMEZ-BOLEA, A., SAIZ-JIMENEZ, C. - *Anatase as an Alternative Application for Preventing Biodeterioration of Mortars: Evaluation and Comparison with Other Biocides*. International Biodeterioration & Biodegradation 64 (5). 2010, 388–96.

[30] KUBACKA, A., SUÁREZ DIEZ, M., ROJO, D., BARGIELA, R., CIORDIA, S., ZAPICO, I., ALBAR, J.P. ET AL. - *Understanding the Antimicrobial Mechanism of TiO₂-Based Nanocomposite Films in a Pathogenic Bacterium*, Scientific Reports 4 2014, 4134.

A first approach to the tile collection from the *Convento de Santana* (Lisbon, Portugal)

Mariana Almeida

Instituto de Arqueologia e Paleociências da Universidade Nova de Lisboa (Portugal), Instituto de História Contemporânea da Universidade Nova de Lisboa (Portugal) and Doctoral fellow SFRH/BD/100982/2014 of the Fundação para a Ciência e Tecnologia (Portugal), Lisbon, Portugal, mariana.brit.almeida@gmail.com

Rosa Varela Gomes

Instituto de Arqueologia e Paleociências da Universidade Nova de Lisboa, Lisbon, Portugal, rv.gomes@fcsh.unl.pt

Mário Varela Gomes

Instituto de Arqueologia e Paleociências da Universidade Nova de Lisboa, Lisbon, Portugal, mv.gomes@fcsh.unl.pt

SUMMARY: The remains of the Santana Convent, Lisbon, which was founded in ca 1562 and active until the end of the 19th century, underwent two major excavation campaigns in 2002 and 2009/2010, which revealed several structures and a vast amount of archaeological materials. Amongst those, a collection of almost ten thousand tile sherds stand out. This assemblage comprises the entire chronology of the convent occupation, with examples from every different evolution stage in Portuguese tile production during the convent's long history.

KEY-WORDS: Lisbon's Convento Santana, Early Modern Archaeology, Pattern tiles; Figurative tiles

CONTEXT OF THE FINDINGS

This paper stems from the study of the numerous archaeological materials unearthed in the excavations of the Santana Convent in Lisbon. Given the sheer size of the collection, the task of studying this assemblage is laborious and time consuming and, therefore, still unfinished, despite the efforts of a multidisciplinary team. Thus, the data presented here is preliminary, and the overall numbers or some details may be further rectified.

To comprehend this tile assemblage is important to bear in mind the chronology of foundation, abandonment and refurbishing of this convent. The year of 1562 marks the entrance of the first nuns and the convent was occupied until the death of the last one in the late 19th century in the wake of the dissolution of the monasteries in Portugal. The convent was then partially demolished and turned into the Real Instituto Bacteriológico de Lisboa (Royal Bacteriological Institute of Lisbon) and later on Instituto Bacteriológico Câmara Pestana (Câmara Pestana Bacteriological Institute, from now on referred to as IBCP), after the proclamation of the Portuguese Republic in 1910.

Through the available documentation, we know of at least three large construction and reformulation campaigns, in 1674-1681, 1707 and 1729. Another campaign took place after the earthquake of 1755, since it affected the buildings greatly [1].

In 1880, after the dissolution of the convent, a great number of tiles from Santana were taken to the Madre de Deus convent, in Xabregas (the future Museu Nacional do Azulejo, MNAz, the National Tile Museum), which was itself undergoing a process of remodelling, with the contributions of other convents [2].

The excavation in the Santana Convent took place in two different campaigns in the context of the transformation of the former IBCP space into new facilities for the Faculdade de Ciências Médicas da Universidade Nova de Lisboa (Nova Medical School). The first occurred in 2002, focusing on an area already cleared of buildings, and acted almost as a preliminary survey for archaeological potentiality. The second campaign took place between 2009 and 2010, encompassing the remaining area of the IBCP, at the same time as the actual construction works. Several original structures of the convent were found, such as part of the cloisters (with graves within it), three wells, rooms and garden constructions, part of a subterranean water conducting channel and several cess pits formed from the 17th to the 19th century.

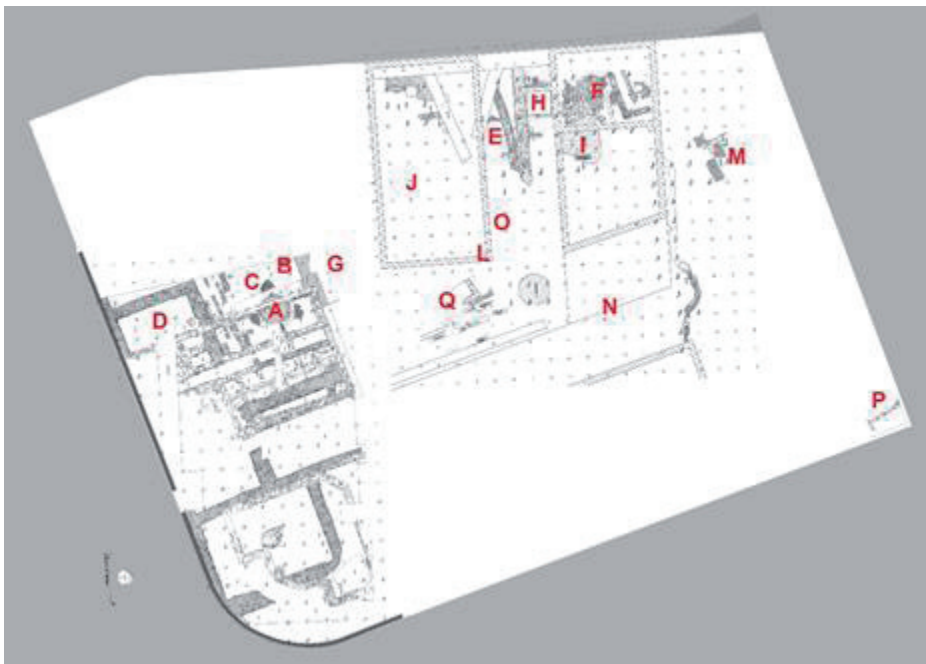


Figure 1: Plant of the exhumed structures.

The first archaeological campaign (2002)

The first work focused on an area mainly corresponding to the cloister and part of the church, which explains the large amounts of tiles collected, some of them whole. Most of them were found inside a large well, which was partially filled during the IBCP conversion works, although made sometime during the convent's occupation. That information is presented more thoroughly in table 1, with the amount of tile fragments per place (or locus) identified during the excavation. The description "grid squares" concerns an area with some, hard to identify and overall not noteworthy, structures of the convent, which was excavated according to a pre-defined grid system, following a serial numeration.

Thus, none of the tiles of this campaign were found *in situ*, nor directly associated to any structures, so their original placement within the convent is almost impossible to ascertain.

<u>Locus</u>	<u>Map location</u>	<u>Number of fragments</u>	<u>%</u>
Well 1	A	5938	89.37
Pit 4	B	23	0.35
Pit 5	C	1	0.02
Grid squares	N/A	439	6.61
Surface finds	N/A	243	3.66
Total	N/A	6644	100

Table 1: Amounts of tile fragments, per *locus*, found during the first excavation campaign.

The second archaeological campaign (2009/2010)

As mentioned above, the second archaeological campaign accompanied the construction works and encompassed all the remaining area of the IBCP.

3271 tile fragments were recovered during this campaign period, but this number is not closed since the treatment and analysis of these materials is not yet concluded, with a substantial number of materials still to be washed. Among those, there may be some tile fragments.

<u>Locus</u>	<u>Map location</u>	<u>Number of fragments</u>	<u>%</u>
Sector II	D	129	3.94
Channel area	E	98	3.00
Stable	F	894	27.33
Cistern	G	98	3.00
Compartments	H	46	1.41
Pits (6 and 7)	I and J	234	7.15
Ossuary under the arch (Pit 11)	L	52	1.59
Tiled floor area (Qs 271-274)	M	974	29.78
Well 2	N	567	17.33
Well 3	O	2	0.06
Reception area	P	7	0.21
Necropolis area, graves and ossuary	Q	110	3.36
Surface finds	N/A	60	1.83
Total	N/A	3271	100

Table 2: Amounts of tile fragments, per *locus*, found during the second excavation campaign.

The *loci* with the highest number of tiles are a paved indoor area underneath the Institute's parking lot and a garden range under the stable (identified as M and F in the map, respectively). Both were not greatly affected by the conversion of the convent into the IBCP, since the buildings on top of them had no basement, and that is why these were also the only places where *in situ* tiles were found.

According to the plants of the convent from 1871 and 1910, these spaces were devoid of constructions. Nevertheless, the excavation revealed some structures we have interpreted as gardens and/or a “*casa de fresco*”, both very popular features in baroque architecture, in the stable area (F in the map, Figure 2.3) and the tiled floor area beneath the IBCP parking lot (M in the map, Figure 2.1 and 2.2).

The other *loci* mentioned in table 2 either have residual numbers of tile fragments, or are clearly filled with debris at a later date, such as well 2, (identified as N in the map) or even the result of soil disruption, the case of pit 11, which was purposefully created during the construction of the IBCP and placed under a loadbearing arch (identified as L in the map). It was originally an ossuary fashioned by human bones, coming from the disruption of the cemetery, and a debris pit with a large amount of materials on top of that.

The number of farmsteads in and around big cities in Portugal is significant, reflecting the high-society taste for the countryside. We should keep in mind that this particular convent was inhabited by the daughters of the nobility and they were certainly used to a high standard of living. Convent gardens reminded the community of the pleasures of profane life, not necessarily with the goal of spiritual salvation, but they were also a space for introspection and the encounter with God.

There are several examples of tiles used in garden benches, flowerbeds and other architectural elements in different points in the country, such as the Nossa Senhora do Desterro Convent, in Monchique [3], or the recreational farmstead of the Archbishop of Braga [4].

DIACHRONY OF THE DECORATIONS

The tile assemblage from Santana Convent spans the entire chronology of its occupation, indicating the change in taste in society and, above all, the economic capacity of the monastic community.

For the time being, only the data from the second campaign regarding tile types and decoration is available but it is assumed to be representative of the whole collection. The amounts of fragments for each type are presented below, in table 3.

In addition to the tile fragments gathered during the excavation works, we will also be including information regarding tile panels we safely know were once placed in the Santana Convent and were taken to Madre de Deus Convent in Xabregas in the late 19th century, during its refurbishing to become the IBCP. This information is clearly stated in a report written in 1907, listing and describing these tiles, and the places where some of them were later placed in Xabregas [9].

We believe this information is vital to comprehend the overall tile decoration of the convent, because there are some types of tiles we have not found during the excavations, but were taken. Each case will be presented in its chronological timeframe.

<u>Tiles typologies</u>	<u>Number of fragments</u>	<u>%</u>
Hispano-Moresque tiles	1	0.03
Checkered geometric (<i>enxaquetado</i>) tiles	386	11.80
17 th -century polychromous pattern tiles	205	6.27
17 th -century monochrome pattern tiles	197	6.02
18 th -century blue and white figurative tiles	242	7.48
<i>Albarrada</i> tiles	194	5.93
18 th -century frame tiles	945	28.89
Single figure tiles	279	8.53
Sponged tiles	61	1.86
Polychromous 18 th and 19 th -century figurative tiles	5	0.15
Indeterminate	756	23.11
Total	3271	100

Table 3: Amount of tiler per decorative type, from the second archaeological campaign.

16th century

Only one small Hispano-Moresque tile fragment was found (Figure 2.4). It was produced with the *cuerva seca* technique and was unearthed on a pit created by overturned soil during the 19th-century works (as were most pits).

Given its production type, it is most likely Spanish in origin, from Seville (Triana), since there are no known kilns where *cuerva seca* tiles were produced in Portugal. The decoration is phytomorphic and finds an excellent parallel in the Manueline cloister of the Pena Palace, Sintra, although we cannot be sure if those tiles were originally from this palace or applied later in the 19th century by order of King Ferdinand II. [5] However, this kind of tiles are not uncommon in Portuguese church walls and altars from the 16th century.

Two interesting tiles from this period also deserve a mention. These were found in one of the largest pit like deposit of materials (the ossuary under the arch, pit 11) created in the 19th century. They are the earliest examples of tiles in the *maiolica* technique in Santana and present all the characteristics of a 2x2 pattern tile, with a polychromous phytomorphic central motif and a chronology from the second half of the 16th century (see Figure 4.5). They were produced in Talavera de la Reyna, Spain, and are not common in Portugal but were popular in Spain after their use in the Escorial Palace in 1570 [6]. Later on, during the 17th century this pattern was slightly adapted and incorporated into the Portuguese pattern repertoire, in both polychrome and blue on whit. [7].

Blue, white and green geometric checkered (*enxaquetado*) tiles were also found, the first two in higher number. It is plausible to assess that the convent tile wall covering in the 16th century was a geometric scheme, since they comprise 11% of the total amount, as seen in table 3. This conclusion is further supported by the three small sets of *enxaquetado* tiles still held together by mortar (Figure 3.1). These decorations have a chronology from the end of the 16th century until ca 1634-1640, and is quite common on Portuguese churches and monasteries [8].

In addition to the tiles found during the archaeological excavation, we know that several similar tiles were taken to the Madre de Deus Convent in Xabregas in the late 19th century, some of them

were reapplied in the Saint Aute cloister, where they still are today, occupying a total area of 38 m by 3 m [9].

17th century

Panels

It is noteworthy that no fragment from a 17th-century figurative panel was found during the excavations. However, in the list of tiles taken from the Convento Santana to Xabregas in the late 19th century, eight such panels are mentioned. These are described as small, unartistic, the images lacking in proportion and expression, painted in blue, yellow, purple and green, two of them showing the dates of 1635 and 1640. The themes are religious in nature and typical of this period: a monstrance surrounded by angels holding candles, Saint John the Baptist, Holy Family, a sphere with the inscription “IS”, Saint Didacus (better known by his Spanish name Diego) and Saint Anthony, the most venerated Portuguese saint [9].

The first of the panels listed above, the monstrance, has been positively identified and published [10]. The panel with the MNAz inventory number 131, with a monstrance and the caption “LSO SANTISIMO SACRAMTO”, identified by the museum’s researchers as coming from Santana, might match the one described in the 19th-century list as only a monstrance, not mentioning the caption which is quite visible.

The panel with the Holy Family described in the list of tiles taken to Xabregas, in our opinion matches the panel with the inventory number 170 from MNAz, which is presented as having an unknown origin. [11] Although we are aware that this is a very common depiction, we believe that it might have been originally placed in the Santana Convent.

As for the panel showing Saint Didacus, who is not a usual representation in Portugal, it is described as having a religious habit and the inscription “S. Diogo”, which is exactly the same as panel n° 140 from MNAz, and given its rarity, we believe it might have come from Santana Convent. Furthermore, the MNAz panel was first published, in 1995, as originally having been placed in Casa Pia de Lisboa but in 2012 that information was changed to unknown provenance [12].

Patterns

In this study of 17th-century pattern tiles we follow the typology and nomenclature created by Santos Simões in 1971 [13].

Pattern tiles represent 12.3% of the total amount, with 402 examples, divided into two groups: polychromous and monochrome: the first with 205 and the second with 197 individuals. So far 53 distinct patterns were identified, most of them with few copies each, approximately half having less than 5. We have recognized 24 polychromous patterns (P-11, P-43, P-73, P-74, P-84 P-314, P-387, P-388, P-391, P-604, F-10, F-13, F-14, F-22, C-1, C-36, C-43, C-71, C-82, C-91, C-115/118, B-1, B-18 and B-29), 14 monochrome patterns (P-68, P-211, P-212, P-219, P-318, P-376, P-475, P-489, F-19, C-4, C-27, C-66, B-38 and B-59A) and 15 which, despite having been registered as polychromous by Santos Simões, present a monochrome version (P-107, P-119, P-206, P-370, P-389, P-401, F-17, F-39, B-32, C-12, C-69, C-95, C-96, C-97 and C-123) and of these six present both forms (P-206, P-370, P-401, C-96, C-97 and F-39) (see Figures 3.2, 3.3, 3.6, 4.1, 4.2, 4.3 and 4.4).

Similarly, we have found some variations to the patterns listed by Santos Simões. This is not surprising, since this researcher worked in the decades of 1960 and 1970 and he only registered patterns still in place during his travels and inquiries. This fact has been acknowledged by researchers dealing with this type of tiles [14].

Despite the numbers being somewhat similar (see table 3), there are far more polychromous patterns than monochrome patterns in this assemblage. Thus, each blue and white pattern has many more specimens each, especially if we take into account that the pattern examples now in MNAZ we safely know came from the Santana Convent, are 2x2 blue on white, and cover a considerable surface. It is close to the P-206 pattern (Figure 4.2), with a central camellia or magnolia motif, particularly popular during the reign of King John IV (r. 1640-1656) and with a symbology akin to roses, that is a connotation to the Virgin Mary and perfectly adequate for a convent whose invocation is Saint Anne [14]. In fact, this decorative family is the most represented one in this collection.

The large amount of patterns with very few individuals may indicate a deliberate dismantlement of patterns tiles before the 19th-century partial Santana Convent demolition.

As for typologies, we find the entire pattern spectrum in this assemblage, with 28 patterns, 7 friezes, 16 frames and 6 bars, which is the usual proportion.

Most patterns are of the 2x2 type (51 out of 55), two are 4x4 and only one is 6x6. The use of “smaller” patterns may be connected to the place they occupied in the convent, or even to a decorative programme where each pattern was confined to a small area, like only one wall, since 4x4 and 6x6 schemes are meant to cover large spaces [15].

Chronology wise, we also find the entire spectrum of pattern production. It begins with *caixilho composto* compositions, continues with 2x2 patterns which appear around 1620, 4x4 from 1630 onwards, as well as 6x6, both still sporadically used in the 1670's. Blue on white appears around 1680 and continues into the beginning of the next century [16].

18th century

Figurative panels

The largest amount of tiles found in the 2009/2010 campaign relate to 18th-century panels and their frames. Panel tiles represent 7.48% (242 examples) and frames 28.89% (945) of the total amount (see table 3).

Frames present some variations to baroque winding acanthus leaves, but with a certain coherence. There is a degree of diversity of corner elements, with *mascarons* (grotesque faces) (Figure 3.4), flowers and *putti* (Figure 3.5). Most show characteristics of the first half of the 18th century, so we might associate them to the 1707 and 1729 renovation campaigns in the convent.

As for the panels themselves, the tiles are very fractured and the compositions, and overall themes, are very hard to assemble or even understand. Up until now only a small panel from this campaign was put together, found in the stable area. It depicts a lady, richly dressed and holding a martyr's palm branch and standing in front of a tower, with a small lightning bolt to her left side (Figure 5.1). Given these attributes, we believe that the panel represents Saint Barbara. The characteristics of the composition point to a chronology of the second quarter of the 18th century.

The 1907 list we have been alluding, with the tiles taken to Xabregas, mentions the transfer of three small panels of the same size representing Saint Michael, Tobit and the angel and the archangel Raphael [9]. Quite possibly these and the panel found during the archaeological excavations were part of the same set.

Despite not being able to restore any other compositions, we would like to draw attention to two interesting and with high technical quality tiles. The first (Figure 3.8), found in the stable area, presents thin deep blue brushstrokes and depicts part of a building with a portal in the Manueline style, with part of a female religious image to the left side, over a decorated corbel. That lady seems to be sitting on an armchair and holding a small child on her lap, which is the typical representation of Saint Anne, the patron of the convent. The images we have of the convent from

the 19th century show a very different façade than the one showed in this tile, which is closer to the architecture of Madre de Deus in Xabregas, or even that of the Hospital Real de Todos os Santos, Lisbon, whose representation in a tile panel from *ca* 1740, from the famous tile painter P.M.P, now in display in Museu de Lisboa – Palácio Pimenta, closely resembles the tile fragment in this assemblage [17]. The fragment might depict a reality of the Santana Convent we do not know of and was modified later on, or even destroyed by the 1755 earthquake. It may even illustrate an imaginary or idealized space, perhaps narrating a real or biblical event like the panel from the Santa Marta Convent (now a civil hospital) depicting the moment when Saint Clare of Assisi casts out the troops of the Holy Roman Emperor Frederick II, standing in front of the Monastery of San Damiano (Saint Damian) [18].

The other tile worth mentioning, also unearthed in the stable area, shows a male image, slightly less skilfully drawn but still with high quality and detail. It is safe to say that both tiles belong to separate panels. The man portrayed wears a wide brim hat and holds something we cannot see behind his back, possibly being a street vendor (Figure 3.7).

In the first excavation campaign of 2002, some interesting 18th-century panel tiles worth mentioning were found. One shows the head and torso of an angel playing trumpet, it has very thin brushstrokes and delicate features, with a strong contrast of light and dark conveying volume and texture, especially in the wings (Figure 3.9).

Also from that campaign two complementing tiles were found, showing a blue on white composition with a human faced and bird winged *putto* on top of a tulip and other smaller flowers tied with a bow and apparently coming out of what seems to be a bottleneck. Its chronology should be the first half of the 18th century. The tulip is not a usual subject in Portuguese art in general, and finds its way into Portuguese single figure tiles through Dutch influence. This tulip in particular is very realistic and its best parallel is a frieze of 33 polychrome tulips made in Hoorn *ca* 1630-1650, a period known for a tulip craze and might be the inspiration for this panel [19] (Figure 5.5).

Besides the other tile panels taken to Xabregas we have already mentioned, eleven others are also featured in the 1907 list, some of them incomplete and one with a large size 2.70 m x 2.37 m, although not mentioning the decorations. [9] We can speculate if the tiles collected during the archaeological excavations are the missing ones from said list. We cannot but associate this information with the panels displayed in the “D Manuel” room in MNaz, where we find six panels originally from the Santana Convent. In fact, they were cut apart and dismembered to fit the walls and the spaces between the windows, depriving them of their original character [2]. They would probably have a frame, which might have been left in the convent. The large panel in the room far exceeds the measurements mentioned in the list, as it has 2.94 m by 7.56 m since no decorations are mentioned in the list, it is impossible to be sure.

Single figure tiles

The 2009/2010 campaign unearthed 279 single figure tiles, corresponding to 8.53% of the total amount (see table 3). We have established four main motifs, from highest to lowest amount: flowers, animals, boats and anthropomorphic depictions. These are, indeed, the most common themes, alongside buildings and fruit baskets [20].

We have not identified caricatures like the ones found in the São João de Tarouca Monastery, perhaps because that was a male religious institution and those tiles could be considered rude and unladylike [21].

Flowers dominate this production, with carnations, tulips, lilies and daisies in similar proportions (Figures 3.10 and 3.11). As for animals, this assemblage comprises mostly dogs, all of them sleek greyhounds running and with pointed ears, and undefined wading birds in various positions,

perhaps herons (Figure 3.12). One tile shows an owl surrounded by foliage (Figure 3.13), and another a rabbit or hare, with long ears and a short tail (Figure 5.2).

The tiles representing boats all present the same typology: in profile, with two triangular sails and highly stylized (Figure 5.3). Lastly, there are two tiles with human depictions, both incomplete and male (Figure 5.4).

As for the tiles' chronology, the owl seems to be the oldest one, because it does not present any corner element. All the others have them, one is a four-petal flower with a circle in the centre, clearly inspired by Dutch prototypes and slightly earlier than the other corner element, the typical star with a dot at the centre and corners.

Since most of the monastic complex was demolished and occupied by the IBCP, it is difficult, if not impossible, to identify which places within the convent had this type of tiles. We know they were profusely used in kitchens during the reign of King John V (r. 1706-1750) such as the Trinas Convent in Lisbon [22]. From the 1755 earthquake onwards, during King Joseph reign (r. 1750-1777), these tiles were placed in less noble areas such as corridors, walkways and staircases [20].

Albarradas

Lastly, we have to mention the *albarrada* compositions, heirs to the 17th-century polychromous tradition, representing a large trophy like vase, with flowers and fruits, usually surrounded by birds. In the first half of the 18th century, only in blue and white, those compositions were widely used as connecting elements between larger figurative compositions [23].

In the 2009/2010 excavation campaign 194 were found (5.93%) consistent with *albarrada* compositions (see Table 3).

In the 2002 campaign a composition with 4x3 tiles was unearthed, showing a large trophy like high vase, with *mascarons* as handles, over a small pedestal surrounded by wide winding acanthus leaves and *putti* holding an element which would appear in other tiles (Figure 4.6). It is possible that it would be a footer for a larger composition, perhaps even the one on display in MNAz.

We have written information concerning a tile panel with a “trophy” located beside the grave of the poet Camões, placed there by the poet Miguel Leitão de Andrada (1553-1630) [24]. The designation of “trophy”, somewhat vague, might indicate an *albarrada* composition, with a high footed vase and two handles (akin to a volute krater) and similar to the formal model for trophies. This tile typology knows its production peak in the third quarter of the 17th century, but it was already fashionable in the first half of that century. This chronology fits in with the placement of those tiles in the Santana Convent. Even though we do not know the precise date when this panel was placed, it would have to be between the death of Camões in 1580 and the death of Andrada himself in 1630.

This type of compositions could have been used in sequence, creating some kind of frieze, like the one we find in the São Quirino Church, in Sobral de Monte Agraço, dating from 1738, complete with a frame of winding acanthus leaves [25].

ESTIMATE COVERED AREA

Assuming that all tiles obey the standard measurement of 14 cm on each side, that is 0.0196 m² in area, we can estimate the approximate area covered by tiles in Santana Convent.

Thus, the complete 22.000 tiles we know were sent to Xabregas in the late 19th century [9] should cover around 418 m². We do not know if this number includes the panels in display in the “D. Manuel” room in MNAz, but that is unlikely given the lack of information regarding that particular decoration in the 1907 report, so we are estimating that area as well. The large panel

measures 2.94 m x 7.56 m (22.23 m²) and the lower frieze has the same width and 8 tiles in height, so 1.12x7.56 m (8.47 m²). The opposite wall is harder to measure due to its wide windows. Conceptually, for the purpose of this exercise, we assume that the windows take up around 20% of the wall space, which would give a number of around 24.56 m². The third wall of that room presents a panel measuring approximately 11.17 m². All of that added gives an area of *ca* 66.43 m².

The 9.915 tiles (even though we are counting here all tile fragments, that number should not be far from the truth, because an extensive work of collages was made) accounted for as of yet in both archaeological campaigns amount to 188.38 m².

Adding all these areas, we get *ca* 672.81 m² in tile covered area in the Santana Convent. Of course not all tiles were used simultaneously, given the disparity in chronology within the tile collection. However, spaces showing diverse types of tiles, with different chronologies, are not unheard of. Stating that all the tiles we found were in the walls during the late 19th century refurbishing works is probably going too far, but we do know that all the tiles taken to Xabregas were still on its walls [9]. So, tiles with different chronologies would have been on display in the 19th century, with examples from the 16th, 17th and 18th century still in their places.

This exercise is purely theoretical, and is meant provide a perspective on the size covered by tiles in this convent, a feature which is not usually regarded. We believe that this is a viewpoint worth exploring as the research develops.

SOME CONCLUSIONS

At this point in the study of the tile assemblage from the Santana Convent we can draw some conclusions. The purposeful removal of several tile panels during its adaptation to IBCP in the last years of the 19th century greatly conditioned the formation of archaeological strata, which explains the lack of tiles from figurative compositions from the 17th and 18th centuries. This absence is particularly notorious regarding central motifs, since a significant number of frames from those periods were found. It is also true that some tiles might have been stolen during those troubled times in the 19th century, and that matters would have been even worse if the people in charge of renovating the Madre de Deus Convent in Xabregas, the future MNAz, had not taken tiles from Santana Convent for storage [9]. Unfortunately, at the same time several other convents throughout the country were going through the same fate and information got lost and scattered. Maybe one day we will know all the tiles originally placed in Santana Convent. This event, along with the possibility of theft after the dissolution of the convent, or even before that, create an undertone to the study of its archaeological finds, since they might really not correspond to the reality.

The decoration of each space within the convent will probably remain unknown to us due to the changes in the 19th century. What we can surely say is that a wide surface would be covered, and that specimens from different chronologies would be in use simultaneously, as happens in almost all spaces with such a long diachrony.

It would be of great importance if it could be uncovered with certainty which tiles now in the MNAz's old fund came from Santana Convent, in order to create a more realistic panorama of its tile decoration and ideological programme, since, for now, we find a dichotomy between Franciscan and Marianne imagery, as was alluded before, in a clear discourse between the invocation and the religious affiliation of the convent. The efforts of the "*Devolver ao Olhar*" project have been extremely important towards that, by finding the origins of some panels and assembling others, still with an unknown origin, which may well be the Santana Convent, such as the recently rediscovered panel showing the birth of Saint Anne, where a triple reference to her name stands out [26].

The lack of Hispano-Moresque tiles 16th-century tiles and the presence of *enxaquetado* tiles, and the two Spanish majolica tiles lead us to believe that the first tile covering was comprised of *enxaquetado* tiles, certainly a taste-based option, since other possibilities were available at the same time, and the community had the economic means to choose.

In the 17th century the convent was decorated with pattern tiles, punctuated by small evocative tiles depicting saints and religious imagery, which were still in place in the 19th century, when they were taken to Xabregas. Perhaps we can relate this redecoration with the convent's expansion works that took place in the 1670's and 1680's, a period when blue on white was becoming the norm.

The 18th century is the period from which the largest number of tiles was found, although we could only place together a small panel depicting Saint Barbara. The high number of frames would be connected to the purposeful removal of figurative panels in the late 19th century. Also from this period, we found a significant collection of single figure tiles, with different motifs, which would have been placed in less important spaces within the convent. Probably this perceived lack of importance and aesthetic value was the reason they were not taken to Xabregas.

We can safely say that many rooms in this convent had their walls covered with tiles, which would cover more than 650 m², from its foundation until its dissolution and that several changes took place throughout time.

Despite what we do not know regarding the convent's architecture and tile covering, it is important to recognize that, as with several other monastic houses, it would have tiles in its church, garden, cloister and perhaps other common spaces such as the kitchen, refectory, staircases and walkways.

Thus, more than 32.000 tiles were used, creating a valuable collection, not only for its number but also for the quality of many panels, which reflect this particular Portuguese taste, able to transform the architectural austerity of a religious space, bringing life and rhythm to its walls, coolness to warm months. In short, the convent was, in the Portuguese case, a space of social gathering offered by the parlour in European courts [27].



1



2



3



4

Figure 2 – 2.1: Overall view of the tiled floor area (M in the map); 2.2 – Detail of the *in situ* tiles in the tiled floor area (M in the map); 2.3: Detail of the garden area beneath the stable (F in the map); 2.4: Hispano-Moresque tile fragment.

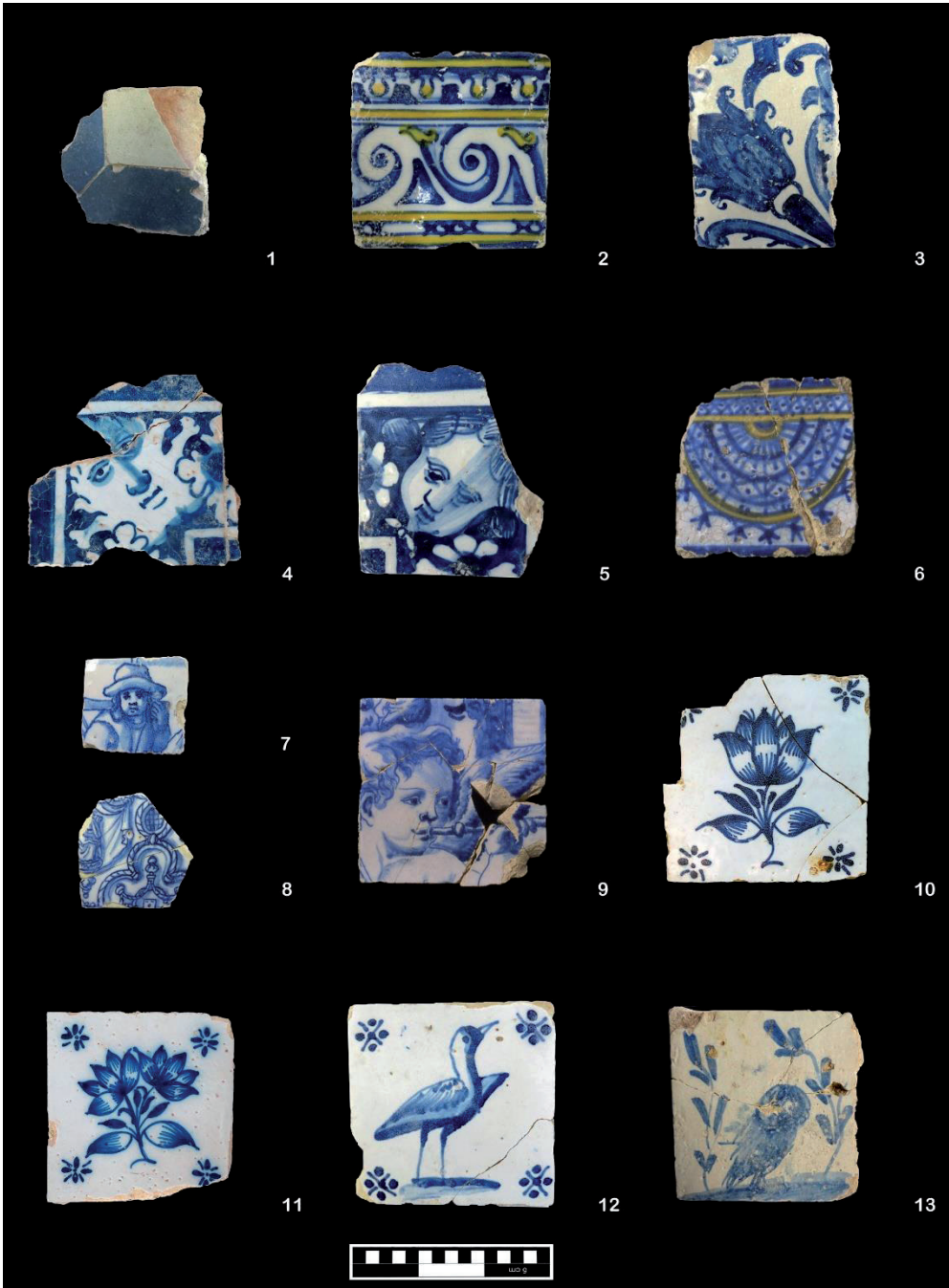


Figure 3 – 3.1: Group of three *exaquetado* tiles still hold together; 3.2 – 17th century pattern tile, C-36; 3.3 – 17th century pattern tile, P- 119; 3.4 –Corner element of a 18th-century frame depicting a *mascaron*; 3.5: Corner element of 18th century frame depicting a *putus* 3.6: 17th century pattern tile, C-43; 3.7: Fragment of a 18th-century panel tile depicting a man; 3.8: Fragment of a 18th-century panel tile depicting part of a building; 3.9: 18th-century tile with a musician angel; 3.10: Single figure tile with a flower; 3.11: Single figure tile with a flower; 3.12: Single figure tile with a bird, possibly an heron; 3.13: Single figure tile with a bird, possibly an owl.



Figure 4 – 4.1: 17th century pattern tile, P-388; 4.2: 17th century pattern tile, P-206; 4.3 –17th century pattern tile, B-29; 4.4: 17th century pattern tile, double F-14; 4.5: Polychromous 16th century tile from Talavera de la Reyna; 4.6: 18th-century composition with an *albarrada* in the centre and flanked by two angels.

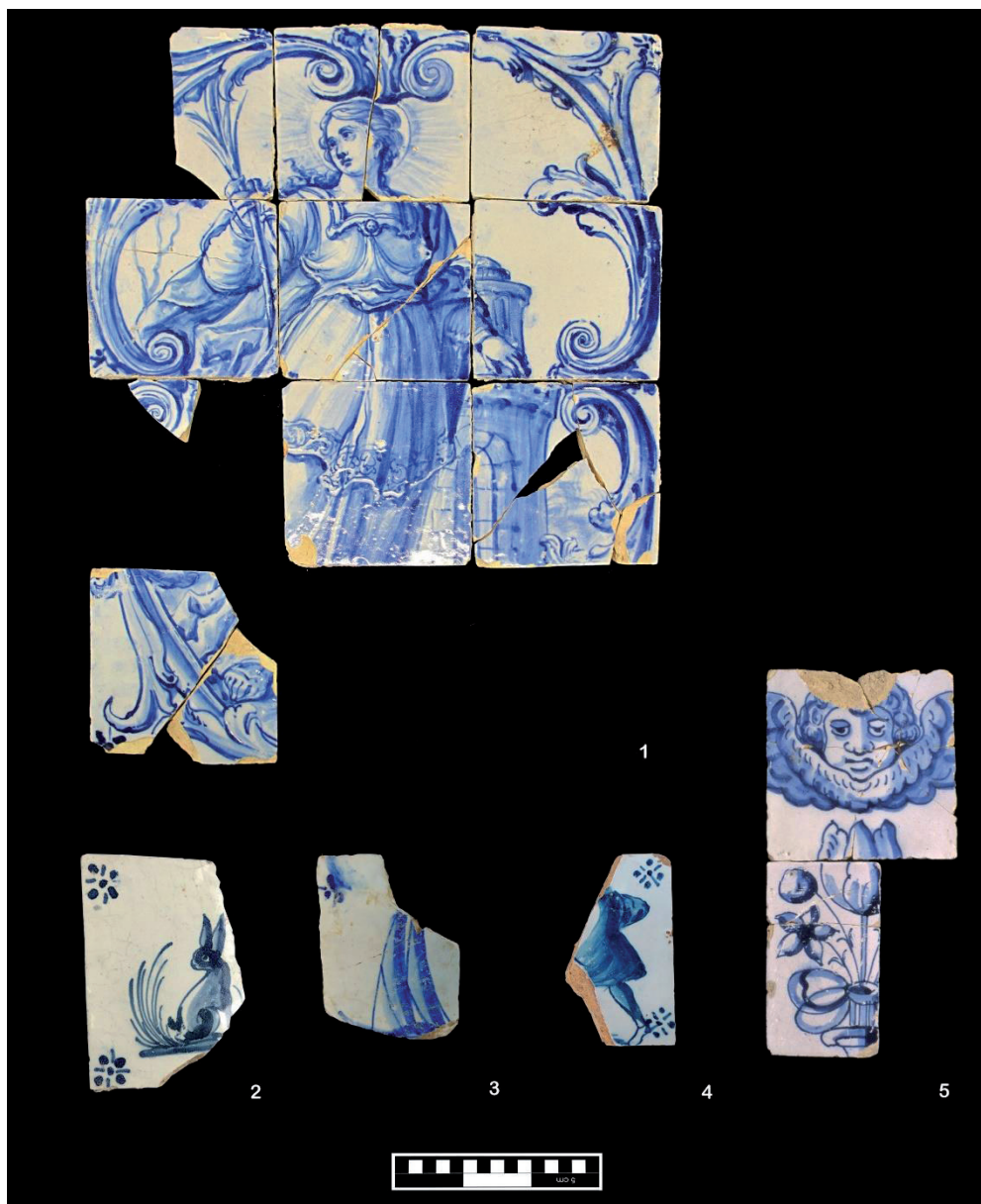


Figure 5 – 5.1: Small panel depicting Saint Barbara; 5.2: Single figure tile with a rabbit or hare; 5.3: Single figure tile with a boat; 5.4: Single figure tile with a man; 5.5: Two 18th-century composition with a tulip and an angel.

Bibliographic references

- [1] For information regarding the history of the convent, see GOMES, Mário Varela and GOMES, Rosa Varela - *Escavações arqueológicas no Convento de Santana, em Lisboa. Resultados preliminares*, Olisipo, nº 27, Lisboa, 2007, pp. 75-92; GOMES, Mário Varela, GOMES, Rosa Varela and CASIMIRO, Tânia Manuel – *Convents, monasteries and porcelain: a case study of Santana Convent*, Lisbon Global Pottery1. Historical Archaeology and Archaeometry for Societies in Contact, Oxford, pp. 93.101.
- [2] MECO, José – *O pintor de azulejos Manuel dos Santos – Definição e análise da obra*. Boletim da Assembleia Distrital de Lisboa, vol. 86, Lisboa, 1980.
- [3] MARADO, Catarina Almeida - *Antigos Conventos do Algarve. Um percurso pelo património da região*. Edições Colibri, Lisboa, 2006, p. 96.
- [4] CARVALHO, Rosário Salema and SILVA, Libório Manuel - *Azulejo em/in Braga – O largo tempo do Barroco*. Centro Atlântico, Braga, 2016, p. 176.
- [5] CARNEIRO, José Manuel and GAMA, Luís Filipe - *Palácio - Nacional da Pena – Roteiro*. Instituto Português do Património Cultural, Lisboa, 1987, p. 30.
- [6] FRANCO, Núria - *De barro y esmalte. La colección de azulejos del Museo de Cáceres*. Amigos del Museo de Cáceres, Cáceres, 2014, p. 44, 57-58 and see also PLEGUEZUELO, Alfonso *La colección Carranza de cerámica en el Museo Comarcal de Daimiel*. Ayuntamiento de Daimiel, Daimiel, 2008, p. 64-65.
- [7] PAIS, Alexandre - *A Monarquia Ibérica. Um Gosto Português – O uso do azulejo no século XVII*, Museu Nacional do Azulejo, Lisboa, 2012, pp. 114-121.
- [8] PAIS, Alexandre - *Painel de azulejos enxaquetados*. Azulejos – Obras do Museu Nacional do Azulejo. Éditions Chandeigne, Lisboa, 2009, p. 24.
- [9] AA. VV - *Azulejos*. Boletim da Real Associação dos Architectos Civis e Archeologos Portuguezes, Tomo XI. Nº 4, 1907, pp. 282-288.
- [10] PEREIRA, João Castel-Branco - *As colecções do Museu Nacional do Azulejo*. Instituto Português dos Museus, Lisboa, 1995, p. 73.
- [11] MONTEIRO, João Pedro - *Registos hagiográficos e painéis narrativos. Um Gosto Português – O uso do azulejo no século XVII*, Museu Nacional do Azulejo, Lisboa, 2012, pp. 264-271.
- [12] PEREIRA - *Op. Cit.*, p. 73 and MONTEIRO, *Op. Cit.*, p. 269.
- [13] SIMÕES, João Miguel dos Santos - *Azulejaria em Portugal no Século XVII*. Fundação Calouste Gulbenkian, Lisboa, 1971.
- [14] PAIS, Alexandre - *Padrões (ainda) imprecisos. A Azulejaria de repetição no século XVII*. O uso do azulejo no século XVII, Museu Nacional do Azulejo, Lisboa, 2012, pp. 83-95.
- [15] SIMÕES - *Op. Cit.*, p. 64.
- [16] SIMÕES - *Op. Cit.*, p. 65; PAIS, Alexandre – *Op. Cit.* p. 93 and MECO, José - *O Azulejo em Portugal*. Edições Alfa, Lisboa, 1989.
- [17] LEITE, Ana Cristina - *O Rossio e o Hospital Real de Todos-os-Santos*, Hospital Real de Todos -os-Santos 500 anos, Museu Rafael Bordalo Pinheiro, 1993, pp. 56, 57, 60, 61.
- [18] VELOSO António José Barros, and ALMASQUÉ, Isabel - *Hospitais Civis de Lisboa, História e Azulejo*. Edições Inapa, Lisboa, 1996, p.101.
- [19] DONGEN, Alexandra Gaba-van - *Painel de azulejos com túlipas*. O Brilho das Cidades. A Rota do Azulejo, Fundação Calouste Gulbenkian, Lisboa, 2013 p.258.
- [20] MECO, *Op. Cit.*, p. 150.

- [21] CASTRO, Ana Sampaio and SEBASTIAN, Luís - *Mosteiro de São João de Tarouca – A faiança de revestimento: séculos XVII e XVIII (intervenção arqueológica 1998-2001)*. Património Estudos, nº 4, 2003, pp. 168-179
- [22] SIMÕES, João Miguel - *O Convento das Trinas do Mocambo – Estudo Histórico Artístico*. Instituto Hidrográfico, Lisboa, 2004.
- [23] SIMÕES, João Miguel dos Santos - *Azulejaria em Portugal no Século XVIII*. Revised and updated edition, Fundação Calouste Gulbenkian, Lisboa, 2010, p. 57.
- [24] AA. VV. - *Azulejos*. Boletim da Real Associação dos Architectos Civis e Archeologos Portuguezes. Tomo X. nº 6, 1906, p. 303-304.
- [25] MECO, *Op. Cit.*, p. 145.
- [26] PAIS, Alexandre and ESTEVES, Lurdes - *Devolver ao Olhar. A Herança de Santos Simões*, Edições Colibri, Lisboa, 2014 p. 83-94.
- [27] TRONI, Joana - *Catarina de Bragança (1638-1705)*. Edições Colibri, Lisboa, 2008, p. 215.

Lead glazed ceramics in Lisbon (16th-18th centuries)

Tânia Manuel Casimiro

IHC/IAP-FCSH, AAP, Lisbon, Portugal, tmcasimiro@fcsh.unl.pt

José Pedro Henriques

IAP-FCSH/Cota 80.86, Lisbon, Portugal, jpedro.henriques@gmail.com

Vanessa Filipe

IAP-FCSH/Cota 80.86, Lisbon, Portugal, vanessafilipe@gmail.com

Carlos Boavida

IAP-FCSH, AAP, Lisbon, Portugal, cmpboavida@gmail.com

SUMMARY: The first documents referring to lead glaze ware production in Lisbon go back to the 16th century with the reference to green glazed pots, mentioned the Lisbon Potter's Regulation. Although no kiln site producing exclusively lead glaze wares was actually found in Lisbon some evidence suggest that these objects may share the same kilns with redware production. The most frequent shapes are large flared bowls, cooking pots, jars, plates and chamber pots, in green and/or yellow, among other forms used in domestic activities. This paper aims to present the types of objects produced by Lisbon potters, discussing production techniques, shapes and function as well as other glazed objects used in Lisbon households based on vessels found in two archaeological excavations in Lisbon, in Carnide and Rossio, reflecting domestic activities from approximately 1580 to 1755.

KEY-WORDS: pottery; lead glaze; green glaze, vessels; domestic consumption

INTRODUCTION

In 1572 the Lisbon Potters' Regulation divides the craft officials between redware, green glazed, white glazed and roof tile officials (*louça vermelha, louça verde vidrada, louça branca vidrada* and *telheiros*). This is one of the first documents in Lisbon mentioning the production of lead glazed wares (Correia, 1926). Older documents are known in other parts of the country such as in Coimbra where a 1556 regulation already mentions the production of lead glaze, calling the craftsman as *malagueiros* (Carvalho, 1921). Based on archaeological evidence the production and widespread consumption of Lisbon lead glaze may have started during the second half of the 15th century although an earlier production of lead glazed green objects should not be put aside, considering it may have occurred in other areas of the country, although further evidence is necessary to interpret this possible phenomenon (Ferreira *et al.*, 2016). In the Tagus valley area kilns producing lead glazes have been found at least in Alenquer (Cardoso, *et al.*, 2016), Mata da Machada (Carmona e Santos, 2005) and Santo António da Charneca (Barros *et al.*, 2012). The majority of these findings correspond to 16th century debris areas although an earlier production could go back to the 15th century.

In some kiln sites in Lisbon, dated from the 15th century, it is not rare to find biscuit fire objects, possibly indicating that those recipients would be glazed afterwards, nonetheless the presence of lead glazed objects in the kiln wasters is rare and it is impossible to determine if those were produced in that particular kiln or not.

The 1572 document, possibly not the first to be made but the one which survived, can in fact give us important information about craft organization and the importance of lead glaze production. The organization of the lead glazed potters is quite similar to the redware and tin glaze potters. Every year two of the craftsmen were chosen to be the craft judges. The role of these two men were to serve as inspectors making sure that production was controlled and followed the established rules. They actually had to be called every time a kiln was opened after fire so they could check if production was being made as ordered by local authorities. If the craft followed the same rules as the Coimbra craft even the amount of clay and sand would be regulated (Carvalho, 1921). This was actually quite possible considering that the document states that sometimes potters did not produce the pots according to their own regulation, suggesting that each craft might have had its specific documents (*irem ver o tal forno se a louça é feita desenganadamente como lhe manda seu regimento por serem informados que os ditos oleiros muitas vezes fazem a louça de maneira que tanto que a poem no fogo estala assi por ser mal cosida como por ter pouca areia*).

All the objects produced in Lisbon had a red micaceous fabric varying from light red (2.5 YR 2/4 MSCC) to dark brown (5YR 5/4 MSCC) in colour. The sherds present a homogenous fabric with small-medium quartz, lime and micaceous inclusions. The pots were all wheel thrown showing rilling marks on the interior surfaces.

One of the main responsibilities of these judges was to examine who was able to become a lead glazed potter by signing a letter. In order to be one any craftsman had to know how to prepare the clay, build the object, prepare the glaze, glaze the recipient and fire it (“*Item saberaa enfornar, vidrar, e cozer*”). But he could just not simply acquire the glaze mixture already prepared since he had to know how to use a small kiln in order to oxidize the lead and transform it into dust (*Item saberaa fundir o chumbo em hua fornalha de modo que se faça em poo muito meudo e se pineire*), he also had to learn to grind and sieve the sand (*Item saberaa moer a area que se lhe bota e peneirala*) and add the right amount of copper oxide to give it a green colour (*Item saberaa deitar lhe o cobre por seu peso*). Although no yellow or brown glazes are mentioned in this document they are frequently found in Lisbon domestic environments and sometimes even associated to kiln wasters (Fig. 1). Paste observation makes us conclude that these were also made in Lisbon, thus although the regiment does not mention yellow glazed pottery. These objects are mostly associated to the second half of the 17th century onwards.

This document is also very specific concerning what type of objects the potters had to do in order to pass the exam: *alguidares grandes e pequenos* (large and small flared bowls), *frigideiras* (frying pans) and *tijellas de fogo* (cooking bowls), but also *panellas de mea arroba cada hua* (large boiling pans) *panellas mais pequenas e de toda a sorte* (smaller boiling pans) *almotolias grandes e pequenas* (large and small bottles), *tachos* (cooking pots) *enfusas de toda a sorte* (all types of jars) *pratos de toda a sorte* (all types of plates) *canos para telhados de cinco palmos* (pipes to be used in roofs), *malegas grandes que chamão vermelha* (large bowls), *escudelas de feição de porcelana* (bowls shaped as porcelain) and *hu servidor* (a pot which could have many functions including being used as a chamber pot).

The majority of these pots has a direct translation into the archaeological record and these were the shapes that Lisbon inhabitants were using when using lead glazed pottery in their daily activities.

However, there are other documents that can actually help to understand what were these glazed pots used for. Inventories, letters and especially recipe books mention the used of glazed pots in many different functions especially cooking, storing and serving. Whenever those documents provide information about the function of these recipients they will be mentioned.

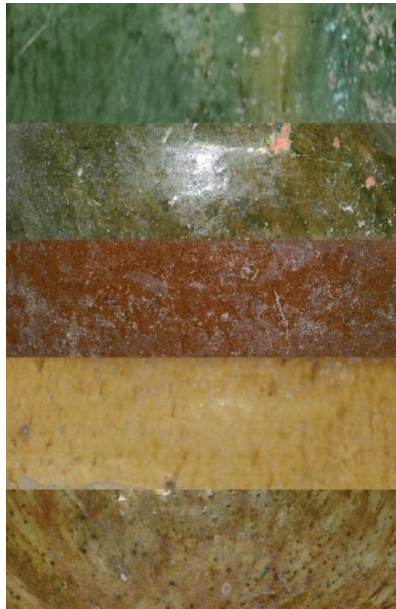


Fig. 1: Different glaze colours from ceramics recovered in Lisbon

The objective of this paper is to present the lead glaze artefacts found in two sites in the Lisbon area, one in Carnide and the other in Rossio square, and try to connect those shapes with the forms mentioned in the potters' regiment, discussing their use in the domestic activities of everyday lives. The different chronologies of both sites permit an overall perspective on what type of lead glazed objects were being used in domestic environments during the Early Modern Age in Lisbon.

Lead glaze pottery is frequent in early modern archaeological sites in Lisbon, however, it is still difficult to understand in what amounts. The quantity present in archaeological contexts has many variations related to chronology, type of site and even site formation. These were the issues which the authors had in mind when selecting the sites.

The sites

The excavation of an area in order to replace sewer systems and general refurbish of a city square in Carnide lead to the discovery of more than one hundred medieval storage pits transformed into dumpsters in the 16th and 17th centuries (1550-1650 approx.) (Fig. 2) (Caessa and Mota, 2014). These reflect the daily use of ceramics and other material culture elements used by that population in what can already be considered a rural area, although associated to important religious houses. Literally thousands of objects, in different stages of conservation, were found inside those abandoned storage pits (Fig. 3). Unfortunately, it was not yet possible to study this collection entirely, meaning that we are not yet able to provide a definitive number of all the ceramics found on site. Some studies are being made. Chinese and European imports and some daily ceramics were already published (Casimiro, Boavida and Moço, 2017; Casimiro, Boavida and Detry, 2017) and painted redwares and tin glazes are in preparation to publish soon.



Fig. 2: Carnide excavation (after Caessa and Mota, 2014)



Fig. 3: Carnide cooking pots

In Carnide, glazed and tin glazed objects, either imported or produced in Portugal, correspond approximately to two thousand recipients. In spite of this large number this does not correspond to more than 10% of the overall collection thus unglazed ceramics seem to correspond to around 90%. The conclusions related to these numbers must bear in mind social and economic background of that population and always aware that this is a dumpster site and reflects the use of ceramics for almost a century in an area in the outskirts of the city. These numbers although corresponding to what people consumed in their households does not mark a specific moment in time and can only be used to state a consumption tendency.

Most of the lead glazed ceramics correspond to recipients used to store, serve and prepare food. No evidence of glazed cooking pots was identified, what in fact can be explained by the amount of unglazed vessels. In fact, boiling pans and frying pans, with no surface treatment or burnished inside are the highest amount of finds together with drinking cups. When analysing the lead glazed ceramics thoroughly we are aware that not all of them present the same fabrics, thus

produced in different areas and possibly not all of them made in Lisbon, with similarities with the finds from Alenquer and Santo António da Charneca (Cardoso, *et al.*, 2016; Barros *et al.*, 2012).

As for the other site an excavation made in the summer of 2017 discovered the remains of a house destroyed on the morning of 1 November 1755, located on the edge of a building's block in the southwest area of the Rossio square. Three compartments were excavated, including an inner yard (Fig. 4). The structures were well preserved on the level floor and while the yard, a private area with a direct exit to a main street and a water well, had a cobbled floor the other two were covered with red floor tiles. One of these inner compartments seems to have been used as a kitchen. The typology of its construction with a well, a tank with the walls covered in tiles, and the material culture found inside, including a knife on the floor and a redware pot close to the well, used as a water container, suggests this use.



Fig. 4: Rossio excavation

The other compartment has no especial feature that would help us recognize its use, however the abundance of objects inside, some of them large storage vases *in situ*, may indicate its use as a pantry or storage area. This site is extraordinary since we are able to understand what type of lead glazed wares were in use in that particular house, in one particular moment. This is a perfect site to study the consumption of glazed pottery in the mid-18th century Lisbon considering that all the objects found were in used the day that house was destroyed. Once again the conclusions made about the pottery found here have to bear in mind that this was located in one of the richest

areas of the city and the type of ceramics found inside suggest a wealthy social background (Casimiro, *et al.*, in press). Green glazed boiling pans and frying pans correspond to the majority of the kitchen ware, although unglazed objects were also in use. That being said the majority of the cooking ware was actually glazed and corresponded to 21% of the overall collection which indicates a clear increase when compared to the Carnide collection. A large complete storage pot, yellow glazed was found *in situ* and possible used as a container for organic domestic garbage.

The objects

Alguidares (Fig. 5A) are among the most frequent lead glazed objects found in Early Modern Portuguese archaeological contexts, and one of the form potters had to know how to do to pass their exam. These have oblique walls, flat bases and everted rims. The inner surface of these robust objects was most of times covered with green or yellow lead glaze although unglazed and burnished objects are occasionally found. Fabric observation reveals that not all of them were made in the same place and several origins have to be considered. In the Carnide excavation red paste *alguidares* were found covered with green and yellow lead glaze as well as objects with light buff sandy fabrics suggesting a southern Spanish Andalusian production. As for the Rossio excavation only three fragments were found, one green and two yellow glazed.

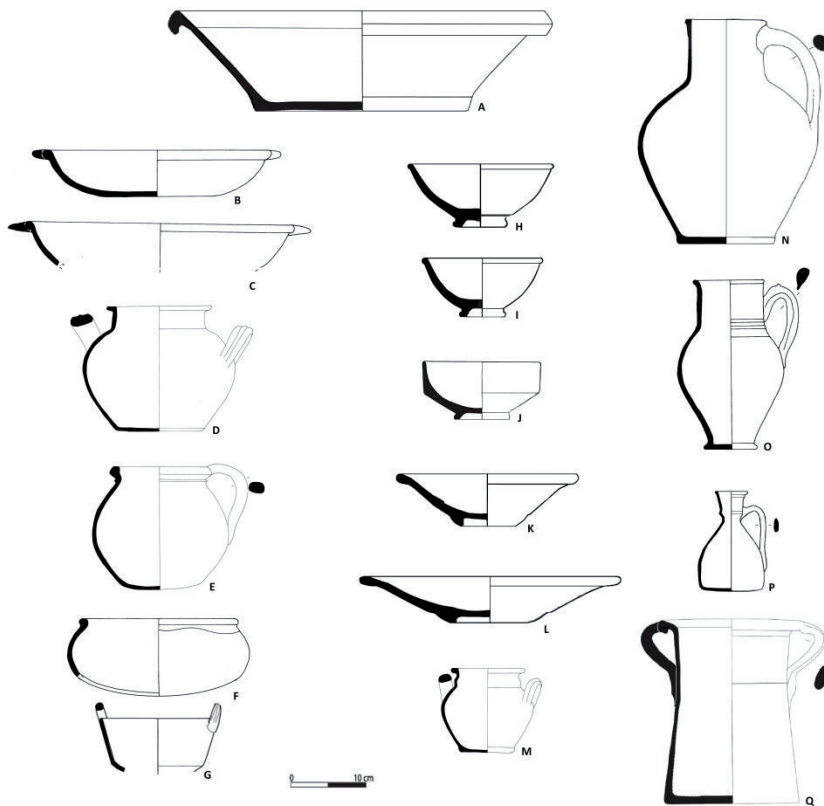


Fig. 5: Glazed objects found in Carnide and Rossio

These were among the most versatile objects in use in any Lisbon dwelling and a true multifunctional object. In the *Livro de Cozinha de D. Maria*, a recipes book written somewhere in mid-16th century these are used to wash fresh cut quinces (“*alguidar de agua fria para colocar marmelos aparados*”) (Manupella and Arnaut, 1967: 87). In another recipes book by *Luís de Távora*, written around the same time, the *alguidar* is used to knead dough in several recipes (Barros, 2016). However, these were not only used in the kitchen. In the *Livro de Contas de D. Catarina* (1571), there is a reference to two glazed objects used in the pharmacy (*alguidares vidrados para a botica - 140rs*) (Cândido, 2013, 186). Although we have no reference to the size of these objects (and the regiment mentions different size *alguidares*) in late 16th century two of these objects cost *140 reis*, which would be a considerable price at that time. Adding to this there are several archaeological examples of repaired *alguidares* with several iron staples revealing that the price of the object justified the time spent in its repair (Boavida, 2017:1824 (Fig. 6).



Fig. 6: Repairs in a large green glazed *alguidar*

Although the 1572 document mentions *frigideiras* (frying pans) and *tijellas de fogo* (cooking bowls) we found no evidence of these glazed objects in the Carnide excavation (all of them were unglazed) although a few of them were in use in the Rossio house (Fig. 5 B-C). These were hemispherical recipients with a flat base and straight walls with different sizes some of them with small triangular handles glazed on both surfaces. In the *Livro de Cozinha de D. Maria*, these pots are mentioned frequently when referring to food which needed to be fried or taken into the oven. In the book *Arte da Cozinha* (1680) the recipient which is used to fry food also goes into the oven in the preparation of *Queijo com Lombo de Porco* (Rodrigues, 1693: 5).

Boiling pots (*panelas*) were used in all different sizes especially with the intent of boiling food. Although shapes tend to slightly vary during the Early Modern Age, especially in rims and handles its shape is quite consistent. A globular body with a short narrow neck sits on a flat base (Fig. 5 D-E), a shape shared by glazed and unglazed pots, though most of them are only glazed on the inside. These are in fact among the most frequent references in cook books and some of the recipes have names such as *Olla podrida* still using the medieval name for cooking pot, possibly copied from the Spanish (Rodrigues, 1693). These pans were used to cook food for long hours in a low fire which could be directly over the house's hearth or using a brazier.

Food was also cooked inside *tachos*. In Carnide although hundreds of tachos were discovered none of them had its walls glazed. Once again the Rossio house had a few of these in use at the time it collapsed (Fig. 5 F-G). These were green lead glazed in both surfaces with a hemispherical shape and flat base and two or four handles. These objects are frequently mentioned in the documentation used to stew food. In the *Livro de Cozinha da Infanta D. Maria* bone marrow is cooked inside these recipients (Gomes, 1996). A note should be made mentioning that in spite of the potential of these recipe books in pottery studies a portion of the mentioned objects may have been made of copper or iron, although metal cooking pots are rare in archaeological contexts, possibly related to their recycling characteristics.

In spite of the number of lead glazed objects used in food preparation and cooking most of them were used to serve food and to eat from. Potters had to learn to do plates (*pratos*) of all types. The presence of these objects in the archaeological record is frequent although their shapes change considerably from the 16th to the 18th century. While in older sites these have a trunco-conical shaped objects with a recessed bottom (Fig. 5 K-L), in the 17th and 18th centuries these are going to evolve to large plates with a ring foot, covered with white tin glaze. While they correspond to a large portion of table ware in the early stage of their production latter these are going to be replaced by tin glazed white objects decorated with blue motifs. Several documents mention the used of plates to eat from or to serve food at the table suggesting these had different sizes.

Bowls (*malegas* or *tigelas*) with or without handles were also frequently used, some of them imitating the shapes of exogenous objects such as Chinese imports. Their shapes are quite variable and they could be trunco-conical carinated bowls with a ring foot, or hemispherical ones also with a ring foot (Fig 5 H-I). These could have different coloured glazes in its surfaces such as green outside and white inside or green and yellow, although the most recurrent are covered in and out with the same colour glaze (Figs 7 and 8). Bowls are among the most variable and culturally influenced forms. In the 16th century these were carinated reproducing the shapes produced in southern Spain which endured from the Muslim period. When the Portuguese reach the Indian Ocean and porcelain starts to invade daily lives in Portugal, and in addition to the traditional trunco-conical shape, the hemispherical shape, similar to porcelain, starts to be largely produced and both are going to coexist at least until mid-17th century. These were used to eat from directly and individually or to serve food. In the several recipes from the *Arte de Cozinha* (1680) a book by Domingos Rodrigues food is served in *tigelinhas* and *covilhetes* (small glazed bowls) while many other dishes are served in normal plates (Rodrigues 1693: 144).

Water containers were preferably done in non-glazed ceramics so the process of evaporation could maintain the water fresh and cold. However occasionally there are some recipients which were glazed either in both surfaces or just in their outer surface which were used to contain liquids including water, or most regularly wine. The potter's regiment mentions *enfusas de toda a sorte*, this is, all types of jars. An *enfusa* is usually interpret as a one handle jar with or without a spout in a lobed rim with a flat or ring foot base (Fig.5 N-O). However, other types of jars or bottles were also made such as *almotolias grandes e pequenas* (large and small bottles). These could be used as containers for several liquids and would serve at the table to contain water, wine

or even olive oil or vinegar. They are small recipients with one handle, a narrow neck and globular body (Fig. 5 P).



Fig. 7: Bowl (*tigela*) found in Carnide



Fig. 8: Bowl (*tigela*) found in Carnide

Finally the potters' regiment mentions that in order to get their letter of craft the potter had to demonstrate to the judges he knew how to make a *servidor* (Fig. 5 Q and 9) . This is actually one of the most difficult objects to understand what was used for. It is generally recognized in the archaeological literature that this pot would have the function of a chamber pot or piss pot, nevertheless it is difficult to state if this was in fact the case. Large and robust pots with flat bottoms and a wide rims with two handles, glazed on both surfaces are usually said to serve this function (Figs. 4). They are recovered with different sizes suggesting that different sized people used them and are very frequent in the archaeological contexts from 15th to early 18th century when they start to be replaced by small sized tin glazed white chamber pots. However, these could actually have different uses inside the household and serve other functions. In the Rossio house, in the room recognized as a storage area, there was one of such large vessels (Fig. 9) which could have been used as a pot to gather some of the domestic garbage.



Fig. 9: Yellow glazed pot found in Rossio

Outside the category of domestic used vessels, the regiment also mentions that potters had to know how to make *canos para telhados de cinco palmos* (pipes to be used in roofs), possible with the objective of draining water. None of the collections recovered either in Carnide or Rossio has any glazed pipes, in spite of the large number of roof tiles found both contexts. However, a fragment of a green glazed pipe found in Loulé and interpret as a gargoyle with serpents could in fact correspond to such object (Oliveira and Gomes-Martínez, 2017: 614-616). Other objects which were not mentioned in the potters' regulation were constantly produced by Lisbon potters and regularly found in the archaeological record or mentioned in other documents.

In the 1507 inventory of Beatriz mother of King Manuel, there are references to green glazed pots to contain sweets and other foods. Archaeologically these are found constantly. Small green glazed pots with a flat base and two handles and even a rilled rim so a string could be passed along the neck so a cloth could cover the sweets (Fig. 10) are believed to fulfil this function. In the *Livro de Receitas da Infanta D. Maria* this cloth is often mentioned as a cover (recipe 89). This preservation solution is seen in many Josefa d'Óbidos paintings (Serrão, 1991).



Fig. 10: Green glazed pots found in Carnide

In 18th century Lisbon wealthy contexts is frequent to find a type of green glazed pottery decorated with human faces of small children or woman. This was found in a type of burner in the Marialva palace (Marques and Fernandes, 2006), in a lid in the Cadaval Palace (Casimiro, Almeida and Barbosa, in press) and in another lid in the Rossio house. We are not yet sure if these were made in Portugal or imported however they seem to mark some sort of fashion item in mid-18th century high society since these were never found in less wealthy contexts excavated in the city or its surroundings (Casimiro, 2011; Casimiro *et al.* in press).

Among the most interesting glazed objects found in 16th and 17th century contexts are zoomorphic whistles shaped as horses with or without a rider (Fig. 11). The identification of a fragment of one of these artefacts in the excavation of a kiln area in Alenquer (Cardoso *et al.*, 2016) may indicate they were being produced outside Lisbon though highly consumed by Lisbon populations. These were found covered with green and yellow lead glazes. These are usually interpreted as toys (Gomes, Gomes and Casimiro, in press) since their only purpose was to make noise.



Fig. 11: Green glazed whistle found in Carnide

DISCUSSION

The purpose of this paper was to discuss the production and consumption of lead glazed ceramics in Lisbon domestic environments in Early Modern age. Since no pottery kiln specifically producing lead glazes was ever found this study has to be based in the archaeological remains obtained which resulted from domestic activities.

The majority of the finds has the surface covered with green glaze. Could this be related to the availability of raw-materials? Were green glazed objects more resistant or was it just a tendency of Portuguese consumers to use such colour in objects?

Associating form with function is always a difficult task. Although the majority of recipients are easy to interpret and a cooking pot was destined to boil, fry or stew food, presenting different shapes, an *alguidar* was a multifunctional object and it is hard to specify what such objects were used for or what type of liquids were kept inside an *almotolia*. However, it is our objective at least to start a discussion on the importance that lead glazed objects had in the overall domestic consumption of lead glazed ceramics.

On the other hand, we should also try to understand how did people reacted to these objects. Were they seen exactly the same way as non-glazed objects? How did people felt when food was served or eaten in a yellow or green glazed bowl? Would they prefer it instead of a redware plate or bowl or even a tin glaze plate? All of these objects share the archaeological context thus all of them were used by the same population. What would make people prefer ones instead of the others? Would food look more appealing inside a yellow or a white plate? Would that make any difference at all?

The first major conclusion while analysing a late 16th /early 17th century context and comparing it to a mid-18th century household is that the consumption of lead glazes seems to intensively change during two centuries. While in the earlier context lead glaze is almost exclusively

associated to table ware and small storage in the mid-18th century context the majority of the lead glaze ceramics is associated to kitchen ware with several cooking pots presenting an interior and sometimes exterior green glaze. Glazed objects continue to be used as tableware although lead glaze is clearly replaced by white tin glaze plates and, for the wealthier groups, porcelain.

The origin of objects also changes over time. While in the earlier contexts the observation of the objects' body reveals a wide range of origins, most of them believed to be produced in the wider region of Lisbon with objects possibly made in Alenquer and the Barreiro area, in the 18th century all the glazed objects seem to be produced locally. The change in these consumption patterns may have motivated the end of several workshops and kilns abandonment in late 16th century, especially with the introduction of white tin glazes massively produced in Lisbon.

Except for the large *alguidares* and possibly the highly decorated objects found in the 18th century wealthy contexts there is no other evidence of imports outside the Tagus area or local workshop productions. These were clearly expensive objects and the type which was not thrown away easily based on the evidence of repairs in several of them.

Except for the glazed pipes used in roofs all the objects mentioned in the potters' regiments can be associated to forms recovered from the Lisbon archaeological record, although potters should be free to vary the shapes. Nevertheless, there are some forms found which do not have a specific association with the mentioned forms, thus potters could actually manufacture everything demanded by the local population, such as all sorts of pots and even ceramic toys.

The number of glazed wares is very variable according to the social and economic background of the population and in some contexts associated to less wealthy social groups in mid-18th century the number of glazed ceramics is rather small when compared to wealthy households indicating that these were not cheap objects (Casimiro *et al.*, in press).

CONCLUSION

Glazed wares are a constant presence in all post medieval archaeological contexts since at least late 15th century. However, the amounts of their presence are quite variable. Not many excavations have a full account of all the ceramics found on site, however the ones who have it demonstrate that lead glazes are never the majority of ceramics, a role which is occupied by unglazed redwares. Most of the times they are not even the majority of glazed wares and from mid-16th century onwards tin glaze wares start to occupy that top place.

The type of glazed ceramics is also variable and while in the 16th and 17th century they are mostly related to table wares with plates and bowls occupying the leading role two hundred years later the majority of lead glazed ceramic is used in food preparation.

When analysing numbers, we should also have in mind that each site corresponds to a specific social and economic background and not all of them can be interpreted the same way. Wealthy sites consume high quality products and the number of glazed wares, based in the available evidence seems to be higher in wealthier contexts, possibly indicating that these were more expensive than non-glazed objects.

Unfortunately, it is not easy to understand the value of objects in early modern Lisbon and except for a few documents there are no references to these daily wares. Nevertheless, a major conclusion has to be drawn and lead glazed ceramics, although in different amounts, were present in poor and rich homes.

Bibliographic references

- BARROS, A. L. (coord.). *As receitas de cozinha de um frade Português do século XVI*. Coimbra: Imprensa da Universidade de Coimbra, Coimbra, 2016.
- BARROS, L.; BATALHA, L.; CARDOSO, G.; GONZALEZ, A. A Olaria Renascentista de Santo António da Charneca - Barreiro, In TEIXEIRA, A.; BETEENCOURT, *Velhos e Novos Mundos. Estudos de Arqueologia Moderna*, Centro de História de Além-Mar, Lisbon, 2012, pp. 699-710.
- BOAVIDA, C. Dos objectos inúteis, perdidos ou esquecidos. Os artefactos metálicos do Largo do Coreto (Carnide, Lisboa), in ARNAUD, J. M.; MARTINS, A. *Arqueologia em Portugal 2017 – Estado da Questão*, Associação dos Arqueólogos Portugueses, Lisboa, 2017, pp. 1821-1834.
- CAESSA, A.; MOTA, N. O núcleo histórico de Carnide: o contributo da investigação arqueológica, In Veiga, C. M.; Reis, M. F (coord.) *Quadros da História de Lisboa. A Freguesia de Carnide*, Academia Portuguesa de História e Junta de Freguesia de Carnide, Lisboa, 2014, pp. 85-104.
- CÂNDIDO, G. *Comer como uma Rainha. Estudo de um livro da Casa de D. Catarina de Áustria*. Unpublished PhD dissertation, Faculdade de Letras da Universidade de Coimbra, Coimbra, 2014
- CARDOSO, G.GOMES, J.; , RODRIGUES, S.; BATALHA, L. A produção oleira renascentista na bacia hidrográfica do baixo Tejo, *Al-Madan Online. IIª Série*, 2016, 20 (2), pp. 54-63.
- CARMONA, R.; SANTOS, C. *Olaria da Mata da Machada: Cerâmica dos Séculos XV e XVI*, Câmara Municipal do Barreiro, Barreiro, 2005.
- CARVALHO, A. T. *A Cerâmica Coimbrã no século XVI*, Imprensa de Universidade, Coimbra, 1921.
- CASIMIRO, T. M. Estudo de espólio de habitação setecentista em Lisboa, *O Arqueólogo Português*, S.5, nr. 1, 2011, pp. 689-726.
- CASIMIRO, T.M.; ALMEIDA, M.; BARBOSA, T.M. Largo Duque do Cadaval. Evidências uma catástrofe, In GOMES, M.V.; CASIMIRO, T.M.; BOAVIDA, C. *Terramoto de Lisboa. Arqueologia e História*, Associação Arqueólogos Portugueses. Lisbom , in press
- CASIMIRO, T.M.; BOAVIDA, C.; DETRY, C. Cozinhar e comer: cerâmicas e alimentação em Carnide (1550-1650), In *Actas do Encontro Diz-me o que comes... Alimentação antes e depois da cidade*, Centro Arqueologia de Lisboa, Lisbon, 2017, pp. 105-116.
- CASIMIRO, T.M.; BOAVIDA, C.; MOÇO, A. Louça “de fora” em Carnide (1550-1625). Estudo do consumo de cerâmica importada, In *Actas do I Encontro de Arqueologia de Lisboa Uma Cidade em Escavação*, Centro Arqueologia de Lisboa, Lisbon, 2017, pp. 56-67.
- CASIMIRO, T.M.; HENRIQUES, J.P.; FILIPE, V.; RAMOS, D. Pottery consumption in 18th century Lisbon. In *Europa Post-Medievalis. Post-medieval pottery between (its) borders*. Archaeopress, Oxford, in press.
- CORREIA, V. *Livro dos Regimêtos dos officiaes mecânicos da mui nobre e sêpre leal cidade de Lixboa (1572)*, Imprensa da Universidade, Coimbra, 1926.
- MANUPPELA, G.; ARNAUT, S. (Eds) *Livro (O) de Cozinha" da Infanta D. Maria de Portugal*, Imprensa da Universidade, Coimbra, 1967
- MARQUES, A.; FERNANDES, L. Palácio dos Marqueses de Marialva. Intervenção Arqueológica na Praça Luís de Camões (Lisboa, 1999-2000). *Património Estudos*, 9, 2006, pp. 195-206.
- FERREIRA, L.F.V.; GOMES, M.V.; PEREIRA, M.; SANTOS, F.; MACHADO, I. A multi-technique study for the spectroscopic characterization of the ceramics from Santa Maria do

Castelo church (Torres Novas, Portugal), *Journal of Archaeological Science: reports*, vol. 6, 2016, pp. 182-189.

GOMES, P. O livro de cozinha da Infanta D. Maria, *Olaria*, 1, pp. 93-104.

GOMES, M.V.; GOMES, R.V.; CASIMIRO, T.M., *Ceramic toys and miniatures from the 16th-18th centuries found in Lisbon*, In *Europa Post-Medievalis. Post-medieval pottery between (its) borders*. Archaeopress, Oxford, in press.

OLIVEIRA, L.F.; GOMES-MARTINEZ, S. Gárgula com serpentes. Séculos. XIV-XVI. In CARVALHO, A.; COITO, L.; ALMEIDA, R.; TOUREIRO, S. (coord.) Loulé. Territórios, memórias, identidades” Lisboa/Loulé: MNA; MMLoulé; INCM, 2017, p. 614.

RODRIGUES, D. *Arte de cozinha* devida em tres partes, a primeyra tratta do... Officina de Manoel Lopes Ferreyra, Lisboa, 1693

SERRÃO, V. *Josefa de Óbidos e o tempo do barroco*, IPPC, Lisbon, 1991

The 17th-century tile panorama in the island of Santiago, Cabo Verde: a first approach to a work in progress

Mariana Almeida

Instituto de Arqueologia e Paleociências da Universidade Nova de Lisboa (Portugal), Instituto de História Contemporânea da Universidade Nova de Lisboa (Portugal) and Doctoral fellow SFRH/BD/100982/2014 of the Fundação para a Ciência e Tecnologia (Portugal), Lisbon, Portugal, mariana.brit.almeida@gmail.com

SUMMARY: Cabo Verde was part of the Portuguese Empire and, as such, the churches and other buildings were decorated accordingly, creating a unity of which tiles were a substantial part. Archaeological excavations in several sites in the island of Santiago have revealed a collection of tiles, most dated to the 17th century, which I discuss in this paper. Sites, decorations, chronology and function are presented, along with some preliminary conclusions stemming from the author's doctoral research on Portuguese tiles in Cabo Verde.

KEY-WORDS: Cabo Verde, 17th century tiles, pattern tiles

INTRODUCTION

The aim of this paper is to present an overview of the 17th-century tiles found in the island of Santiago, Cabo Verde, from an archaeological point of view. The research presented here is part of a larger study conducted in the context of the author's doctoral thesis. As such, this is a preliminary exposition on the subject, with some considerations and suggested approaches for further development.

It is safe to say that the main archaeological efforts in Cabo Verde have been greatly focused on Cidade Velha, the old capital of the Portuguese colony (formerly known as Ribeira Grande), especially since it became a UNESCO World Heritage Site in 2009. This prospect does not necessarily reflect the reality of tile distribution, but rather the biases of research interests and public investment. As shown by the recent archaeological excavations in Alcatrazes, sites with historical roots, even if altered or abandoned over the years, do have surprises lurking beneath the surface. Moreover, the study of place names in the island provides clues on other sites worth investigating in the future.

A comprehensive archaeological study is further hampered by the fact that materials from older excavations are scattered through different institutions and are sometimes hard to locate. Finding the whereabouts of some materials is still a work in progress, nothing short of detective work in some cases, and only possible with the priceless aid from the colleagues of the Instituto do Património Cultural (hereinafter, IPC – the Institute for Cultural Heritage, in charge of managing archaeology and historical sites in Cabo Verde, among other functions), to whom I express my gratitude.

For the sake of clarity, when referring to decorations and positioning of tiles within the pattern scheme I follow the terminology and typology created by Santos Simões in 1971 [1].

Recently, the Archaeology Museum of Praia received a large collection of archaeological materials, including a substantial number of tiles. Some of them are tagged, so we know their

specific provenance, but in general they all undoubtedly came from excavations in Cidade Velha. As regards 17th-century tiles, all the tagged tiles belong to the 1999 excavation season at the cathedral and will be dealt with accordingly. The untagged tiles, which date mostly to this century, will be analysed as a whole, in an attempt to provide them with some context, although with great limitations.

HISTORICAL CONTEXT

The islands of Cabo Verde were discovered by the Portuguese in 1460, and the Island of Santiago soon became a busy commercial outpost. In an effort to attract and establish a European population, its inhabitants were given special trading privileges by the Portuguese crown. The geographic position of the island enabled a dynamic slave trade between Europe and the African mainland which fuelled the economy and development of the island. This also contributed to making the archipelago a stopping point for ships heading for India and Brazil. [2].

The capital, Ribeira Grande, grew exponentially, gaining the status of municipality and episcopal see, and saw the building of infrastructures such as churches and chapels, a customs house, a hospital or the episcopal palace [3].

This climate of prosperity lasted until the 17th century, its ending roughly coinciding with the beginning of the Iberian Union (1580-1640), when most authors identify an economic decline. This decline was brought upon by the end of the inhabitants' exclusivity in slave trade with the Guinea coast, direct commerce between the African mainland and other outposts, competition of foreign powers and a growing number of devastating pirate attacks. There was a brief recovery driven by the need of unskilled workforce in the West Indies from the 1650s through the 1670s, but otherwise the economic situation was steadily declining [4].

There was an effort to mitigate these conditions, with the construction of several forts and a large fortress to protect the harbour of Ribeira Grande from hostile vessels, an attempt to produce exportable goods to be traded with ships in transit, and the creation of semi-private shipping companies. The effect was the retention of wealth by a small elite now mainly concentrated in Praia. This gradual deterioration of Ribeira Grande caused the official authorities, as well as the Church, to move to Praia, furthering its decline. Praia would eventually become the capital of Cabo Verde in 1770 [5], and continued to be so after the county's independence in 1975.

The overall outlook of Santiago Island at the dawn of the 18th century is of political and religious unrest, and pirate attacks. Its population depended on subsistence farming and commerce of several goods (sugar cane derivatives, tobacco, *Roccella tinctoria*, physic nut oil, cotton or leather, just to name a few), and still being a stopping point for ships crossing the Atlantic.

TILES IN SANTIAGO

Early 16th century

As in other Atlantic islands, Portuguese settlers brought their lifestyle and architecture to the Island of Santiago. The earliest churches built here, in the late 15th and early 16th century, displayed *Mudejar* tiles and further archaeological investigations at other known historical sites with similar chronologies is likely to expand this list—particularly if we take into account that this is was a period of economic prosperity and wealth.

At this point in time, this type of tiles was manufactured in Seville (Andalusia, Spain), but also in Portugal, specifically in Santo António da Charneca (Barreiro) [6]. However, these two productions are very hard to tell apart macroscopically, and only chemical analyses can unequivocally determine their origin.

According to the current state of affairs, there are eight sites in Santiago with this type of tiles: Nossa Senhora da Luz Church of Alcatrazes, Cathedral of Ribeira Grande, Conceição Church, São Francisco Convent, São Filipe Fortress, São Pedro Chapel, São Veríssimo Fort, São Roque Fort and the Episcopal Palace. It is important to point out that the last three sites were not excavated, but only surveyed. Also, I have not yet located the materials unearthed at the São Francisco Convent and the São Filipe Fortress, and the information I will convey about them is based on the excavation reports [7].

Except for the São Filipe Fortress, all the excavated sites mentioned above have also yielded 17th-century pattern tiles, revealing a continuous occupation of these buildings.

The 17th century tiles in Santiago Island

As was already mentioned, the 17th century marks the end of the prosperity and economic growth of Cabo Verde and Ribeira Grande in particular, but most buildings show pattern tiles dated to that century, which imply a certain degree of maintenance and investment in those infrastructures.

As expected, the vast majority are pattern tiles and a brief description is in order. 2x2 patterns are obtained through the rotation of one tile, a “module”, through an axis on each corner. The decoration within the tiles is as if unfinished and contains elements of continuity, creating a design through the uninterrupted interconnection of ornaments. By adding tiles the pattern can be extended infinitely. There are different types of patterns, depending on how many tiles it takes to create the repetition element 2x2/1, 2x2/2, 4x4/2, 4x4/4, 6x6 and 12x12. Patterns are always limited by tile frames which follow the same rules. There are three types: *Friso* (‘frieze’), *Barra* (‘bar’) and *Cercadura* (‘frame’). These could be used alone or together, often following an arrangement within layouts containing all three [1] [8].

There are seven sites in Santiago with this type of tiles: Rosário Church, Conceição Church, Cathedral of Ribeira Grande, Episcopal Palace, Nossa Senhora da Luz Church, São Francisco Convent and the Misericórdia Church.

Surveys and other finds

Through survey, observations and fortuitous finds only, three other sites have yielded 17th century tiles: Alto do Salineiro, the stream course in Cidade Velha and the Praia Ethnographic Museum.

The first survey took place in 2017 in a small settlement in a plateau area, approximately 2 km north of Cidade Velha. The site was surveyed by Chris Evans, from the Cambridge University mission, and revealed only small tile fragments, possibly indicating the presence of a church or chapel.

In the second site I mentioned, tile sherds were found in a collapsed area of the banks of the stream running through Cidade Velha. They were deposited there through the action of recurring flood waters, which implies the existence of a building, or buildings, with tiles upstream [9].

The third site, the Ethnographic Museum, is located in a 19th-century manor house in the Plateau, which is one of the quarters of Praia. This general area has been inhabited since the late 15th century and gained notoriety over time, as it came to house the governor’s palace (now the President’s official residence). This building in particular was refurbished to accommodate the museum in 1997 and again in 2006. As a result, a display case at the entry hall was put up with some artefacts recovered during these works. One such artefact is a 17th-century pattern tile sherd, which indicates that either the building is older than what historiography would have, or it was built over a previously inhabited area. The history of Praia is well known, but no archaeological excavation has ever been carried out in the Plateau, despite the recent renovation of several buildings [10].

The excavated sites with 17th-century tiles, listed above, and their results will be briefly discussed in order to create a comprehensive panorama. At this point it is important to stress that the archaeological materials from some of the sites are still missing, although they are still sought after.

Nossa Senhora do Rosário Church

The Rosário Church, located at the end of Banana Street, was erected in 1495. It was never excavated, but underwent important conservation works in the 1960's, under the leadership of architect Luís Benavente. It is true that the church was in great need of repairs in several places, including the gothic chapel, the roof and the churchyard. The conservation project was not carried out entirely, perhaps due to lack of funding [11].

Through contemporary reports and photographs we can see that the church walls were completely covered by tiles. Nevertheless, the architect claimed that a great amount of tiles was missing from the walls and that the “panels were incomplete”. To fill in the blanks, 14 375 new replica tiles were commissioned to Fábrica Sant'Anna, in Lisbon, made to look exactly like the 17th-century pattern tiles placed in the church. This work comprised the removal of the entire tile coverage and its replacement by the replicas. It received two major criticisms, which seem very appropriate. First, the new tiles only cover around 1.5 m in height and therefore contrast sharply with the previous arrangement). Second, the pattern itself is awkwardly placed. It is a 6x6 pattern, P-604 (according to the typology created by Santos Simões), but only three of the tile models were applied, creating a strange combination of 2x2 independent compositions.



Figure 1: The replica tiles in Rosário Church (photograph by the author).

There was another smaller intervention in the church in the early 2000's, by the Spanish team that also worked in the São Filipe Fortress, and the São Francisco Church and Convent, but it focused mainly on the concrete floors and ceiling. No further work was done to the existing tiles [11].

The works conducted at the church more recently have uncovered original tile framing elements, C-1 and F-13, in side ground niches running along the outer walls. All of the patterns are very common, with numerous parallels in both Portugal and Cabo Verde.

A new conservation and restoration campaign is being prepared by the IPC [12], mainly to tackle issues tied to water-related damage to the ceiling, walls and floor. This includes removing part, if not all, of the replicas still in place, as many have fallen off due to the absorption of moisture through the soil (a common affliction of tiles) [13]. Furthermore, cement was used freely on the walls and floor of the church and it is rapidly eroding and damaging the structure.

In light of these future works and the need of more tiles to cover the walls, the IPC felt the need to search for the old original tiles removed by Benavente and the replicas which were not applied. Indeed, these were stored together in a compartment constructed for that purpose in the bell tower, and I had the opportunity to roughly assess them. In the future, they will be studied in depth, as part of the research for my doctoral dissertation.

There were two surprises in this collection. One was the presence of the P-604 replica models absent from the inside of the church, which reinforces the idea that the workers that did the replacement were unfamiliar with this type of tiles. The other was the existence of *Mudéjar* tiles, in smaller quantity, but nevertheless there, attesting an older, unknown tile covering of the church.

Although Benavente mentioned the word “panel” in his report, no tiles matching 17th-century figurative tile compositions were found in the stored assemblage until now. He might be just alluding to the pattern tiles as a whole, but we might have to consider theft as a possibility, sometime after their storage, as happened in another case, which will be discussed later on.

Nossa Senhora da Conceição Church

This church was completely buried prior to the archaeological excavations. It is located approximately halfway between Nossa Senhora do Rosário and São Francisco, in a flood bed. As far as our historical knowledge on the urbanization of Ribeira Grande is concerned, this church was the first to be built in Cabo Verde, somewhere between 1466 and 1470, having been abandoned in the 18th century [14].

Excavations started in 2006, with a partnership between Cambridge University, the British Museum, the Ministry of Culture of the Republic of Cabo Verde, and University Jean Piaget of Cabo Verde, under the scientific supervision of Chris Evans and Marie Louise Sørensen [15]. There were four archaeological campaigns, in 2006, 2007, 2014 and 2015, where the entire plan of the church was unearthed, along with a vast amount of materials. In all campaigns, the most numerous type of artefacts was, undoubtedly, Portuguese tiles. There are also some 16th-century *Mudéjar arista* tiles, in a far lesser number than the majolica tiles.

The materials from the first two campaigns were recently moved from a warehouse in the University Jean Piaget to the Archaeology Museum of Praia, and I have not yet had the opportunity to examine them. Differently, the materials of the two later campaigns are stored in the Cidade Velha Cabinet.

During the 2006 excavation season 976 17th-century pattern tiles were recovered, although we cannot be certain of the proportion between patterns and frame elements. The photographs included in the report present three different patterns showing the classical combination of pattern, frieze and frame: P-604, F-30, C-92 [1, 15].

In 2007, 1548 17th-century pattern tiles were retrieved, which feature the same patterns along with C-1, F-10 and F-14 [1]. Some were still *in situ*. A very interesting tile fragment shows the head and chest of a human figure. [9] It is hard to tell who is represented here, or even if it is a male or female character. The best contenders seem to be Saint Michael the Archangel, as the character's blue outfit could be a military uniform, and the Virgin Mary – one of the few female characters depicted in this period –, due to the falling blonde hair. In any event, we can safely say that it belonged to a 17th-century figurative composition, very popular in churches, which broke the monotonous

rhythm of patterns and had a religious theme [16]. The fragment is particularly important because it informs us that Cabo Verde also received figurative tiles during the 17th century, even if very few fragments are recovered in excavations. It might also be a suggestion of purposeful removal of compositions deemed more important and valuable (theft), after the Nossa Senhora da Conceição Church had been abandoned.



Figure 2: Tile fragment from the 2007 campaign [9].



Figure 3: Tile with human torso from the 2015 campaign (photograph by the author).

From the 2014 campaign, 1442 out of 1450 tiles unearthed date from the 17th century. There are a few 16th-century *arista* tiles, as well as 18th century tiles belonging to figurative compositions, attesting the continuous use of tiles in the church decoration until that date. As for pattern tiles, this assemblage comprises all the previous recorded patterns and six new additions, which probably are also represented among the materials from previous campaigns. They are P-3, P-43 (although with some variations to the design proposed by Santos Simões), F-3, F-13, C-1, and C-71 [1]. All are very common in Portugal and in the Portuguese Atlantic islands [17]. There is one interesting addition, namely a type of corner frame designed to be used beside a figurative composition. This furthers what we have been saying about the existence of figurative tiles in churches.

The excavation season of 2015 yielded a total of 2091 tiles, of which 1988 dated to the 17th century. Much like in the previous campaigns, there were some tiles with other dates and no new patterns were recognised. Four specimens are not pattern tiles, but rather part of figurative compositions. One is a corner frame, similar to the one found in the 2014 campaign.

Two others share some characteristics with the 2007 sherd. They depict part of the Virgin Mary's hair and have a good parallel in the panel depicting Our Lady of Conception displayed at the Portuguese National Tile Museum [18], or part of the goat skin worn by Saint John the Baptist, with a parallel in another panel from the same museum [18]. Both are recurrent themes in 17th century Portuguese tiles. Although they apparently depict the same motif, the two sherds probably belong to two separate panels given the differences in colour scheme and brushstrokes. In fact, the second sherd might belong to the same panel as the fragment from the 2007 excavations.

The fourth tile shows what is probably an arm and part of the torso of a man wearing a monk's robe in blue, and a phytomorphic image in yellow. It may be a highly stylised depiction of Saint Anthony of Lisbon, which is a very common theme in Portuguese tiles. The saint is often portrayed holding a branch of white lilies, which could be the case here as well.

Overall, the site of Nossa Senhora da Conceição Church offered a total of 5954 17th-century tiles, which comprises 113,126 m². This number indicates that the building would have been covered in tiles from floor to ceiling. The large amount of tiles found in this church clearly underscores the potential for tile retrieval at historical buildings in Cidade Velha, if more systematic archaeological excavations were to be undertaken.

Cathedral of Ribeira Grande

The cathedral was the most important religious building in Santiago for a long time. Ribeira Grande became the head of a new diocese in 1533, which also comprised a wide geographical area in continental Africa [19]. The construction of the cathedral began in 1556 and officially ended in 1701, with long hiatuses and bursts of construction. The first halt was after the death of bishop Francisco da Cruz in 1571, and the second lasted from 1592 to 1603. These setbacks were due to economic difficulties, the disinterest of local authorities and the disproportionate large size of the cathedral itself. In 1712 the French pirate Cassard attacked Ribeira Grande and looted the cathedral, but apparently did no harm to the structure. Documents from 1738 state that it would be in serious need of repairs, which did not happen due to lack of funding. We know of renovation works taking place in 1745, but according to coeval documentation only the floors and the roof were renovated. In 1754 the diocese head was changed to Santo Antão, and Ribeira Grande was left half abandoned. However, its 1819 inventory report, the cathedral was open to cult and appeared to be in good shape. In 1838 there was a proposal to demolish the building and use its stones to build a new cathedral in Mindelo, in São Vicente. This plan was brought up again in 1875 and, in fact, in 1922 the local government issued a norm to halt the removal of stones by the inhabitants of Ribeira Grande [20].



Figure 4: C-84/F-39 pattern (photograph by the author).

Three archaeological campaigns took place in the cathedral under the coordination of the Portuguese archaeologist Clementino Amaro, in 1989/90, 1991 and 1993. Excavations focused on the main altar, sacristy, transept, and also some deeper trenches to assess the foundations of the walls. The foundations of an earlier structure were discovered, which the Amaro believes to be the remains of a chapel dedicated to Saint Sebastian, dating from the first decades of the 16th century, and relates it with the large amount of *Mudéjar* tiles retrieved [21].

The 17th-century tiles from this campaign are 26 out of 212, with four different discernible patterns: P-604, F-10, B-40 [1] and a frame which combines the characteristics of F-39 in blue and C-84. The latter finds an exact parallel in a chapel in the former Charnais Convent in Alenquer (Portugal), framing a composition of single figure tiles from approximately 1700. [8] For clarity in the text, it will hereafter be referred to as C-84/F-39.

The 1991 campaign focused mostly on the preservation of the structures found in the previous mission, and the consolidation of the cathedral walls still standing. Only to a lesser extent was archaeological excavation involved [22]. There is a container in the Archaeology Museum of Praia with tiles from this campaign, specifically from a side chapel. It shows mostly 18th-century specimens, but there are also other types. The 17th-century tiles are only 16 out of a total amount of 145 specimens, and the only types attested are B-40 and C-84/F-39. It is highly unlikely that these are the only materials from this campaign, but they are the only located thus far.

The same is true of the 1993 campaign, of which I have only found three *Mudéjar* tiles. The information on this excavation season is also scarce.

As regards the 1999 campaign, as was mentioned earlier, the materials were lost for a period and resurfaced recently. Unfortunately, it is very probable that the tiles and other materials found do not correspond to the real amount unearthed during the excavation, and the report does not present the counting of the materials. There was a plan by the same team to study the materials from this campaign and those of 2000, but it was not carried out, probably due to lack of funding. The excavation was preceded by a topographic survey of the site by Martin Hock and Rui Fernandes of the University of Beira Interior (Portugal) [23]. It was part of a broader conservation project carried out by the architect Alexandre Mimoso, which took place in 2000 [20]. As for the excavation itself, it focused on the naves and churchyard, which are areas that had not been excavated before. There was also an emphasis on the area where the older structure appears, which this campaign proved to be indeed the Saint Sebastian Chapel. The monumental staircase seen in the historical paintings of the cathedral was also found [24].

The tile count for this excavation includes 251 specimens from the 17th century. We were able to recognize five different patterns: P-203, P-312, P-604, C-84/F-39, B-40 [1]. The P-312 tiles show a different colour scheme from the one recorded by Santos Simões, with the addition of green.

The last excavation campaign in the cathedral took place in 2003, under the supervision of Portuguese archaeologist Maria Antónia Amaral, but not much information has been conveyed. Some materials have recently been surrendered to the Archaeology Museum of Praia. Of these there are 14 tiles, seven of which are from the 17th century, showing only the pattern P-604.

The total number of tiles from the cathedral inventoried up until now is 716, of which 300 are from the 17th century (approximately half of the full amount), and six different patterns were discerned. If we take into account the size of the cathedral, and compare the amount of tiles retrieved from the Nossa Senhora da Conceição Church, both the amount of tiles and the number of different patterns seem actually too low, unless we assume that only some smaller areas of the cathedral were covered with tiles.

Nossa Senhora da Luz Church, Alcatrazes

Nossa Senhora da Luz Church is the only site treated in this paper that is outside Ribeira Grande. It stands in what formerly was the settlement of Alcatrazes, the first head of Santiago's northern captaincy, created right after the colonization of the island. It is located in an area with low aptness for agriculture and even for commerce, since the harbour does not provide favourable conditions. Around 1516 the status of captaincy capital is transferred to Praia and the village of Alcatrazes steadily declines into historical oblivion [25]. As for the church itself, the chronology of its construction is uncertain. Documents mention the creation of the parish of the same name in 1572, but it is very likely that the church predates it and archaeological data supports this notion [26].

There was a small survey in 2003 with the retrieval of some materials. This was probably carried out by the same team which was excavating the cathedral of Ribeira Grande in the same year. In total, 40 tiles were collected, 38 of which date from the 17th century (the other two are 16th-century *Mudéjar* tiles), and four different patterns were recognised: P-110, P-604, F-13 and C-1 [1]. Pattern P-110 deserves special mention. It belongs to a family of patterns fairly common in Portugal, which exhibit a corncob as their main feature and represent a stylization and adaptation of Asian textile designs.

A proper excavation campaign took place in the church in 2011 and was conducted by the same team from Cambridge University that excavated the Nossa Senhora da Conceição Church, in Ribeira Grande. This campaign sought to discern the chronology and evolution of the building itself, and to define the nature and extent of funerary activity at the site [26].

Another excavation was conducted by the same team in Alcatrazes the following year, in order to locate the settlement. A number of surveys and trenches were made at several sites. One of them, the chapel of Santana, located west of Nossa Senhora da Luz church, revealed 17th-century tiles [27].

Unfortunately, this is one of the cases where the archaeological materials from both campaigns are missing, so all the information we have comes from the field reports. They do not mention any figures, but state that a substantial number of tiles was found. Some were 16th-century *Mudéjar* tiles, but the majority were 17th-century pattern tiles, with patterns, friezes and frames. The church would have the traditional arrangement. As for the designs, the patterns had 'stylised blue and yellow foliate designs' [26]. This is a somewhat vague description, as most patterns present some form of foliage, but it nevertheless provides some chronological clues, since blue and yellow were used from approximately 1635 up to 1675.

This chronology contrasts somewhat with what history claims: that the settlement was completely abandoned in the first decades of the 16th century. In fact, the 2011 excavation proved that the church site had a "long lived archaeological and architectural sequence" [26].

São Francisco Convent

The construction of the São Francisco Convent and Church began in 1657 and the date of its conclusion is unknown [7]. Documents state that approximately twenty years later it was in serious need of repair works and this motivated a renovation campaign. The building was occupied until the dissolution of the monasteries in Portugal in 1834, and after that date the convent was used as farmland [28].



Figure 5: Drawing of the main tile patterns from São Francisco Convent [28].

Unfortunately, this another case in which the archaeological materials are missing, so reports and publications represent our sole sources of information.

A Spanish team excavated approximately one third of the site in 2001 and published their results. A substantial number of Portuguese tiles was found. Unfortunately, these were stolen shortly after being unearthed. The team was able to do a drawing of the main patterns, which we also present here [28]. It features the classical scheme of pattern-frieze-frame, but it raises several questions. The main pattern does not find a match in the bibliography [29], but it is safe to say that it belongs to the camellia family. Moreover, it apparently represents a 2x2 scheme, although the area occupied by the flower itself is only found in 4x4 compositions such as P-472. All camellia patterns have a third corner element which is not seen here, and it is not likely that the classical scheme would lack it. Furthermore, we do not know what the colour scheme was, which is one of the main diagnostic criteria for chronological attribution. The frieze is a variation of F-15, which is also found at other sites and well documented. The frame does not correspond to any pattern present in the bibliography, either because it is truly original or because the drawing is not accurate, given the team only had a limited time to see it and it was largely drawn from memory. The closest pattern is C-3, which is itself fairly uncommon but belongs to a popular family of stylised acanthus leaves [1].

A small survey was carried out by the Portuguese archaeologist Clementino Amaro in 1990, and the resulting materials are now deposited in the Archaeology Museum of Praia. The survey yielded three small 17th-century pattern tile fragments, which seem to correspond to the three patterns drawn by the Spanish team. One has a green leaf compatible with P-472; the second shows a manganese lace frieze; and the last features a design with blue on white and a hint of yellow, which matches the drawing.

Another campaign of excavations took place in 2004, under the responsibility of the IPC. The report does not provide information on the quantities or types of tiles retrieved, so all the data we have concerning 17th-century specimens is a black and white photograph showing four tiles with

different motifs [30]. They belong to the P-312, P-604, C-1 and C-92 patterns [1], which do not match any of the ones presented by the Spanish team.

Misericórdia Church

The Mercy Church was built in 1556, but the hospital would have already been operating since at least 1495 [31], and its brotherhood enjoyed special privileges. [32] The hospital continued working well after the period of decadence of Ribeira Grande, and the church replaced the cathedral after its decline [33]. All that stands today of this complex is the bell tower.

The site was excavated neither in depth nor systematically, but rather underwent a “supervised rubble clearance” in order to evaluate the possibility of reconstruction, in 2006. Despite these circumstances, some materials were retrieved, mainly pottery dating from the 17th and 18th centuries. In this site three out of 12 tiles are 17th-century patterns, while the others are 16th-century *Mudéjar* pieces. The report goes on to say that these are particularly not very fragmented and were not of the same type as those recovered in the same year from Nossa Senhora da Conceição Church [15]. Unfortunately, the same document does not include photographs or counts of these tiles. However, in all likelihood they were stored together with the materials from the 2006 campaign from Nossa Senhora da Conceição Church and I hope to examine them in the near future.

Tiles of unknown provenance

As mentioned above, a substantial number of archaeological materials of different provenances has recently resurfaced. Unfortunately, most of them are not tagged, which makes it extremely difficult to determine their find place. In any case, it is unlikely that the materials came from the cathedral excavations, as each campaign had its own tagging system and the reports suggest that all materials were tagged individually.

This assemblage comprises 161 tiles from the 17th century, with 14 different patterns: P-112 (some with a manganese outline), P-203, P-312 (with the addition of green, which is not referenced in the typology, P-385, P-604, F-13, F-14 (with the introduction of a manganese outline), F-17 (with chromatic alterations, only blue on white), C-1, C-2, C-69, C-71, C-92, B-40 [1]. So, in this assemblage we find patterns from the camellia and corncob families.

SOME CONCLUSIONS

In total, we were able to inventory 5954 tiles from seven different sites dating to the 17th-century, and exhibiting 18 different catalogued patterns. So far there are no patterns exclusive to Cabo Verde. All specimens catalogued thus far have parallels in Portugal and some are, in fact, very common. This indicates that there was not a specific production of tiles for use outside Portugal, which likely translates an effort at uniformity among the colonies, where European settlers struggled to maintain a European lifestyle [34].

There appears to be, however, a difference in distribution of patterns throughout the sites. The most common patterns, such as P-604 and F-13, are found everywhere, but most specific themes and decoration families seem to be found at only one site. Camellia designs occur only at the São Francisco Convent, corncobs at Alcatrazes, figurative compositions at Nossa Senhora da Conceição (although other factors might account for their absence, as mentioned above), and three designs (P-312, B-40 and C-84/F-39) that only occur at the cathedral. This perhaps indicates an attempt to lend an original character to each building, possibly responding to the desire of the brotherhoods, priests or the local communities.

On a purely speculative level, and given what was proposed above, it is possible that the untagged tiles of unknown provenance may be distributed accordingly. Thus, for example, the tiles showing camellia magnolia patterns may have been placed originally in the São Francisco Convent, and

pattern P-312, with its unique addition of green, may come from the cathedral. Of course, for the most common patterns appearing at all sites this exercise is all but fruitless.

It is noteworthy that all buildings dealt with here are religious. The Church was, alongside the Crown, one of the few institutions powerful and wealthy enough to pay for the beautification of buildings. Yet it should be emphasised again that this may not constitute a reliable picture of tile consumption, as manor houses and non-religious buildings have not been extensively investigated.

The overall quality of the tiles is standard when compared to what can be seen in Portuguese contexts. We find the usual glaze blisters, trivet and sagger pin marks, and few examples of over-firing, in typical proportions. There is nothing to suggest the purposeful consumption, or purposeful sale, of low quality tiles, as it might be expected, since that is what the Portuguese faience evidence suggests [35]. This fact implies strongly that there was no specific tile production to be taken overseas. So far, we have not recognised special commissions, as seems to be the case in Madeira and Azores [36]. And the patterns recognised in Cabo Verde are almost all very common, “best sellers” as it were, perhaps reflecting a conservative taste on the part of the islanders or, differently, that the entities responsible for taking the tiles to the archipelago were not willing to take risks. These are mere suppositions due to our lack of understanding of how this commerce really happened: did the residents of Cabo Verde commission tiles they “remembered”, or did they merely order pattern tiles without being afforded the possibility of choosing particular designs.

There is also the question whether there was a time lag in the application of patterns between Portugal and its colonies. It is particularly difficult to clarify this issue since each of the four decorative periods lasts for approximately twenty years. Interestingly, there are yet no designs from the first period (ca. 1600-1630), characterised by geometric *caixilho* compositions and simpler designs. Most patterns found in Cabo Verde fall within the second period (ca. 1630-1650), which sees a rise in creativity, with the corncob and camellia family of patterns (both of which we have been found on the island). The following period (ca. 1650-1680) sees a smaller number of patterns in Cabo Verde, possibly due to economic contraction, the decline in construction and the features of the tiles in this period itself, which sees new intricate and larger patterns, often with manganese, and altar fronts. Thus far, the fourth and last period (ca. 1680-1710) seems to be restricted to the cathedral, with blue and white only designs as a result of Dutch and Chinese influences [1, 8, 37].

As regards provenance, all tiles seem to come from Lisbon, as they share the characteristics of that production centre. In fact, Lisbon was the largest producer of Portuguese tiles and faience, which were fired in the kilns and, most likely, made at the same workshops [38]. Interestingly, this is also true of the other Atlantic islands (Azores and Madeira) and Brazil [39].

Unlike the Atlantic islands, Brazil does not have 16th-century *Mudéjar* tiles, and unlike Brazil, Cabo Verde has no known geometric *enxaquetado* compositions. Another parallel in tile usage lies in the fact that 17th-century figurative tile compositions are extremely rare in both Brazil and Cabo Verde [39].

The pattern tiles that decorated the walls of churches worked as a “visual mantra” of sorts, as their apparent monotony and interconnections, which conveyed a sense of infinity, accompanied by repetitive prayers, helped the worshippers reach a state of mind that favoured the contact with the divine.

Moreover, in a more practical sense, the tile wall coverage makes buildings cooler, which would certainly be a great advantage for places where a large number of people would be gathered under a tropical climate. In addition, tiles were considerably cheaper and lower to maintain than other wall decorations [40].

The tiles presented here are part of a larger study on the Portuguese tiles found in Cabo Verde. I have already alluded to the fact that there are tiles from other periods in the archipelago, between the 16th and 18th centuries, which will, of course, be included in such study. Only by gathering all that data can we achieve a realistic panorama of tile coverage in Cabo Verde throughout the centuries. To complement the information conveyed by the analysis of the tiles, and taking into account the problem with fragments of unknown provenance, that upcoming study will also include other types of material found alongside the tiles in the same archaeological excavations. The context of tile use will thus gain economic and anthropologic undertones, necessary to paint a picture of the Cape-Verdean society, with tiles as a primary source of evidence.

Bibliographic references

- [1] SIMÕES, João Miguel dos Santos - *Azulejaria em Portugal no Século XVII*. Fundação Calouste Gulbenkian, Lisboa, 1971.
- [2] SANTOS, Maria Emília Madeira and TORRÃO, Maria Manuel - *Subsídios para a História Geral de Cabo Verde e a legitimidade da utilização de fontes escritas portuguesas através da análise de um documento do início do século XVI (Cabo Verde ponto de intercepção de dois circuitos comerciais)*, Instituto de Investigação Científica Tropical, Lisboa, 1989, pp. 5-7.
- [3] PIRES, Fernando - *Da Cidade da Ribeira Grande à Cidade Velha em Cabo Verde. Análise Histórico-Formal do Espaço Urbano Séc. XV – Séc. XVIII*, Câmara Municipal da Praia, Praia, 2004, pp. 37-38.
- [4] BALENO, Ilídio - *Reconversão do comércio externo em tempo de crise e o impacto da Companhia do Grão-Pará e Maranhão*. História Geral de Cabo Verde, vol. 3, Instituto de Investigação Científica Tropical, Lisboa; Direcção-Geral do Património Cultural de Cabo Verde, Praia, 2001, pp. 157-234, 136-138; Cabral, IVA - *Ribeira Grande: Vida urbana, gente, mercancia, estagnação*. História Geral de Cabo Verde, vol. 2, Instituto de Investigação Científica Tropical; Lisboa, Direcção-Geral do Património Cultural de Cabo Verde, Praia, 2001, pp. 225-275.
- [5] BALENO, *Op. Cit.*, 210-217, 220; AMARAL, Ilídio do - *Santiago de Cabo Verde: A terra e os homens*. Junta de Investigações do Ultramar, Lisboa, 1964, pp. 181-188.
- [6] BARROS, Luís; CARDOSO, Guilherme and GONZALEZ, António - *Primeira notícia do forno de S. António da Charneca – Barreiro*, Actas das 3.as Jornadas de Cerâmica Medieval e Pós-Medieval: métodos e resultados para o seu estudo, Tondela, 2003, pp. 295-307.
- [7] The Convent of São Francisco presents an interesting case, since its construction began officially in 1657, after a generous donation by a wealthy noblewoman in 1640, and well after *Mudéjar* tiles were no longer in use. A further analysis of the finds would be key to understanding the occupation of this site, but the whereabouts of the materials are unknown. See FERNANDES, Hamilton Jair - *Relatório Preliminar da Escavação Arqueológica no Convento/Igreja de S. Francisco*, Instituto de Investigação e do Património Culturais Ministério da Cultura, Praia, 2005, pp. 11.
- [8] MECO, José - *O azulejo em Portugal*. Edições Alfa, Lisboa, 1989.
- [9] EVANS, Chris and SORENSEN, Marie Louise Stig, - *Cidade Velha, Cape Verde, Archaeological Excavations, the 2007 season*, 2007, pp. 31-32.
- [10] PINA, Domingas - *Antigas residências senhoriais do Centro Histórico da Praia: sua importância histórica e valor patrimonial*. Tese de licenciatura apresentada à Universidade de Cabo Verde – Departamento das Ciências Sociais e Humanas, Praia, 2009.
- [11] MARIZ, Vera - *Cabo Verde no programa de salvaguarda do património português ultramarino – o caso da Igreja de Nossa Senhora do Rosário (1962-1974)*. Atas do Colóquio

Internacional Cabo Verde e Guiné-Bissau: percursos do saber e da ciência, Instituto de Investigação Científica Tropical, 2013.

[12] IPC stands for Instituto do Património Cultural, in English: Institute for Cultural Heritage.

[13] ALMEIDA, Mariana and FERNANDES, Edgar - *Os painéis de azulejo do adro da Igreja de São Simão (Azeitão)*. Velhos e Novos Mundos. Estudos de Arqueologia Moderna, Centro de História de Além-Mar, pp. 551-560.

[14] RICHTER, Konstantin Alexander - *A primeira igreja construída nas latitudes tropicais*. IX Congresso Luso Afro Brasileiro de Ciências Sociais, Salvador, 2011.

[15] EVANS, Christopher and SORENSEN, Marie Louise Stig - *Cidade Velha, Cape Verde, Archaeological Excavation. The 2006 season*. Cambridge, 2006.

[16] MONTEIRO, João Pedro - *Registos hagiográficos e painéis narrativos*. Um Gosto Português – O uso do azulejo no século XVII, Museu Nacional do Azulejo, Lisboa, 2012, pp. 264-271.

[17] CALADO, Rafael Salinas - *Azulejaria na Madeira e na Colecção da Casa-Museu Frederico de Freitas*. Direcção Regional dos Assuntos Culturais da Região Autónoma da Madeira, Lisboa, 1999; SIMÕES, João Miguel dos Santos - *Azulejaria portuguesa nos Açores e na Madeira*. Fundação Calouste Gulbenkian, Lisboa, 1963.

[18] PAIS, Alexandre - *Formas de devoção*. Museu Nacional do Azulejo, Lisboa, 1999.

[19] DOMINGUES, Ângela - *A igreja em Cabo Verde*. História Geral de Cabo Verde, vol. 1, 2001, pp. 119-123.

[20] MIMOSO, Alexandre Braz - *Interpretação e consolidação da Sé Catedral da Cidade Velha*. Revista de Estudos Cabo-Verdianos, número especial Património e Museologia, Universidade de Cabo Verde, Praia, 2013, pp. 1-57.

[21] AMARO, Clementino - *Sé da Cidade Velha, República de Cabo Verde. Resultados da 1ª fase de campanhas arqueológicas*. Velhos e Novos Mundos. Estudos de Arqueologia Moderna, Centro de História de Além-Mar, 2012, pp. 451-464.

[22] AMARO, Clementino - *Escavações arqueológicas na Cidade Velha, Sé. 2ª fase – 23 de junho a 4 de agosto de 1991*. Lisboa, 1991.

[23] HOCK, Martin and FERNANDES, Rui - *Ruínas da Sé da Cidade Velha, Ilha de Santiago – Trabalhos de topografia 1999*. Lisboa, 1999.

[24] DIAS, Ana Carvalho, INÁCIO, Isabel and LOPES, Sandra - *Relatório da intervenção arqueológica da Sé da Cidade Velha Cabo Verde – Outubro/Novembro de 1999*. Instituto Português do Património Arquitectónico, Lisboa, 2000.

[25] BALENO, Ilídio Cabral - *Povoamento e formação da sociedade*. História Geral de Cabo Verde, História Geral de Cabo Verde, Instituto de Investigação Científica Tropical; Lisboa; Direcção-Geral do Património Cultural de Cabo Verde, Praia, vol. 2, 2001, pp. 125-172; RICHTER, Konstantin - *Gone with the wind... Why Alcatrazes, the second European tropical settlement, vanished*. Mande Studies, vol. 16-7, 2015, pp. 119-167.

[26] NEWMAN, Richard; SØRENSEN, Marie Louise Stig and EVANS, Chris - *The Church of Nossa Senhora da Luz, Alcatrazes, Cape Verde. Archaeological and Architectural Investigations*. Cambridge, 2012.

[27] Evans, Christopher; Sørensen, Marie Louise Stig and Newman, Richard - *Alcatrazes, Santiago, Cape Verde Environs: Archaeological Survey and Investigations*. Cambridge, 2012.

[28] CÁCERES, Yasmina and JUAN, Jorge - *La Historia de Cabo Verde a través uno de sus edificios emblemáticos: La excavación del Convento de San Francisco (Cidade Velha, Cabo Verde)*. Actas del IV Colóquio Internacional de Estudos sobre África y Asia, 2002, pp. 209-229.

[29] The catalogue of patterns developed by the Rede de Investigação em Azulejo, available at http://redeazulejo.letras.ulisboa.pt/pesquisa-az/padrao_pesquisa.aspx was also included in the bibliography.

[30] FERNANDES, *Op. Cit.*

[31] PIRES, Fernando - *Da Cidade da Ribeira Grande à Cidade Velha em Cabo Verde. Análise histórico-formal do espaço urbano séc. XV – Séc. XVIII*. Universidade de Cabo Verde, 2007, Mindelo, p. 200; NEVES, Baltazar Soares - *Hospital da Ribeira Grande facho da solidariedade social em Cabo Verde (1497-1834)*. Revista de Estudos Cabo-Verdianos, nº 1, 2013, pp. 1-16.

[32] AMARAL, *Op. Cit.* p. 178.

[33] NEVES, *Op. Cit.*

[34] See, for instance, the struggle of white settlers to keep a diet similar to the one they experienced in Europe, only possible through the expensive import of foodstuffs, in TORRÃO, Maria Manuel - *Dietas Alimentares. Transferencias e adaptações nas ilhas de Cabo Verde (1460-1540)*. Instituto de Investigação Científica Tropical, Lisboa, 1995.

[35] Cabo Verde was part of the “Sugar Route” and the Portuguese Faience found there in general has a lower quality than that found in sites along other trade routes. See CASIMIRO, Tânia and GOMES, Mário Varela *Salt Route. On the world’s routes. Portuguese Faience (16th-18th centuries)*, Lisboa, 2013, pp. 95-96.

[36] SIMÕES, João Miguel dos Santos - *Azulejaria portuguesa nos Açores e na Madeira*. Fundação Calouste Gulbenkian, Lisboa, 1963, p. 8.

[37] PAIS, Alexandre Nobre - *Padrões (ainda) imprecisos. A azulejaria de repetição no século XVII. Um gosto português. O uso do azulejo no século XVII*, Museu Nacional do Azulejo, 2012, Lisboa, pp. 83-96.

[38] GOMES, Rosa Varela; GOMES Mário Varela; CASIMIRO Tânia Manuel; TRINDADE, Rui and SEBASTIAN, Luís - *Production centres – Lisbon, Coimbra and Vila Nova. On the world’s routes. Portuguese Faience (16th-18th centuries)*, Lisboa, 2013, pp. 19-56.

[39] MECO, José - *A expansão da azulejaria portuguesa*. Oceanos, nº 36/37, 1999, pp. 8-19.

[40] HALLETT, Jessica - *A gramática do ornamento: têxteis islâmicos e o azulejo português do século XVII. Um gosto português O uso do azulejo no século XVII*, Museu Nacional do Azulejo, Lisboa, 2012, pp. 101-108.

16th century azulejos - what lies beneath the ground of Lisbon?

Alexandre Pais

Museu Nacional do Azulejo, apais@mnazulejo.dgpc.pt

Maria José Sequeira

Direcção Geral do Património Cultural

Maria de Jesus Monge

Museu Biblioteca da Casa de Bragança

Maria de Lurdes Esteves

Museu Nacional do Azulejo

Inês Castanheira

Archaeologist, Lisbon, Portugal

António Valongo

Archaeologist, Lisbon, Portugal

Cláudia Manso

Archaeologist, Lisbon, Portugal

Victor Filipe

Uniarq - Centro de Arqueologia da Universidade de Lisboa, Portugal

Ana Margarida Cardoso

Laboratório HERCULES, Universidade de Évora

João Manuel Mimoso

Laboratório Nacional de Engenharia Civil

SUMMARY: In the Vila Viçosa Palace, in the southern Portuguese province of Alentejo, lie the still impressive remains of what was the most extensive commission of azulejos produced in Antwerp for Portugal. In an inventory made in 1563 after the death of the 5th Duke of Braganza D. Teodósio, it was documented that no less than 3,658 azulejos commissioned to Antwerp had been delivered up to that year. Until recently there was no known parallel between the pieces commissioned to Antwerp for the Palace of Vila Viçosa and other commissions for Portugal. At an excavation in Lisbon, in the area of the Escolas Gerais five azulejos and two fragments, also of Flemish production, were found in what is thought to be a rubbish tip because they were part of the frame of a panel of which nothing more was found. Other excavations in Lisbon, namely near Casa dos Bicos, Largo do Corpo Santo, Largo do Carmo, Palácio dos Condes de Penafiel and the grounds of the former Igreja de Santo André in Graça produced more fragments of 16th century azulejos of varying provenance giving us a glimpse of an unexpected wealth of types and decorations used in the Lisbon of the 2nd half of the 16th century at a time when a local production of faience azulejos was just starting. Now other pieces are now appearing in different archaeological contexts giving testimony of a discrete but nevertheless clear trend that needs to be acknowledged. The presence of these remains points to the spread of an appreciation for faience tiles and may well be evidence of the foundation for the Portuguese taste for azulejos that has lasted to this day. This communication reviews some of the findings supported by scanning electron microscopy observations and analysis which have tried to integrate some of these cases into known provenances or types.

KEY-WORDS: Renaissance majolica; Faience tiles from Antwerp; Use of instrumental means in the study of majolica

INTRODUCTION

For many years when there was a reference to the presence of Flemish 16th century azulejos in Portugal the what immediately came to mind were those commissioned by the 5th Duke of Braganza, D. Teodósio (c.1510-1563) for his splendid Palace of Vila Viçosa, in the southern province of Alentejo. This Medici-like prince placed an order from Antwerp of what was at the time a prodigious amount of faience azulejos, probably related to the fact that he was preparing the celebration of his marriage in 1559 with Beatriz of Lencastre. We now have a very clear image of this prince and his palace following an important research project funded by FCT (the Portuguese Foundation for Science and Technology), of the inventory of his possessions that was made after his death [1]. Regarding the azulejos we know their number: 3.658, of which ca. 900 still exist today. A study conducted in 2012 enabled us to better understand the motives and intentions reflected in these different sets of panels [2].

Regarding the commencement of the production of faience azulejos in Lisbon, what interests us the most is the date when these Antwerp products arrived in Portugal. The presence of the date “1558”, in two azulejos belonging to different sets is an interesting element because at that time the Flemish artists working in Spain were painting azulejo panels in the same style. These include Frans Andries in the Cathedral of Toledo (1558) and Hans Floris in the Church of Garrovillas (1559), not far from the Portuguese border. We also know that around 1554 a then 18-year old Flemish man named Hans Goos, known in Portugal as *João de Góis*, had arrived in Lisbon and six years later would be known as a “oleiro de Málaga e azulejos” (potter of faience and azulejos) or “potter of azulejos” [3].

An interesting fact about the azulejo commission of D. Teodósio is the fact that, although it was very well connected with the European renaissance style of its time, it was disconnected from the continued Lisbon taste for Hispano-Moresque azulejos that had been in fashion in Portugal since they were introduced from Seville in the late 15th century. Until recently it was thought that there some production of faience azulejos in Lisbon by the late 1560s and during the following decade and only scarce examples of what have presumed to be Flemish patterned pieces, which are mainly attributed to the last quarter of the 16th century. However, recent archaeological excavations in Lisbon seem to give a different picture. In 2012, while excavating in a Lisbon area called “Escolas Gerais”, three archaeologists (Inês Castanheira, Inês Ribeiro and Raquel Policarpo) uncovered five azulejos and two fragments of an exceptional panel of Flemish origin [4]. The excavated site was thought to be a rubbish tip and not the original placement site of the pieces preventing any association of the tiles to a specific building. However, it is an area of special significance because this was the quarter of the ancient university centre of Lisbon, which was established in buildings originally made available by none other than Prince Henry (*Infante D. Henrique*, also known as *The Navigator*). This explains the name *Escolas Gerais*, an ancient designation for universities where many subjects were taught. The University was moved to Coimbra in 1537 after which the area was continually renovated at a time when the aesthetics of the Renaissance would have been suited to faience azulejos panels made in Flanders. The elements that have been discovered show the motifs painted against an orange background which seems to be an unusual choice for Flanders tiles [5] although we also see this in the surviving panels ordered for Vila Viçosa.

In the tiles found in the *Escolas Gerais* area we see garlands of vegetation and fruits with birds and a snake composing part of what may have been an encircling decoration. Also two *putti* playing flutes, where the lower side of the bodies end in acanthus leaves. Two azulejos represent a fantastic bird surmounting what seems to be a frame of probably a heraldic motif that unfortunately was not preserved (figure 1). All the pieces belonged to the same panel and due to the positioning numbers on their backs we know that they were composed by 60 azulejos. Until now the azulejos in the Vila Viçosa Palace were considered, even by local standards, to be amongst the three most important works painted in the workshops of Antwerp. However, the group uncovered at *Escolas Gerais* is also of exceptional quality, arguably even surpassing those commissioned by D. Teodósio seen in the way the painting shows a remarkable mastery in the use of colour and the definition of volume and light. Contrary to the Vila Viçosa ensemble, this seems to have been a single panel, probably depicting the coat of arms of the purchaser at its centre, or some other motif that illustrated a specific purpose.

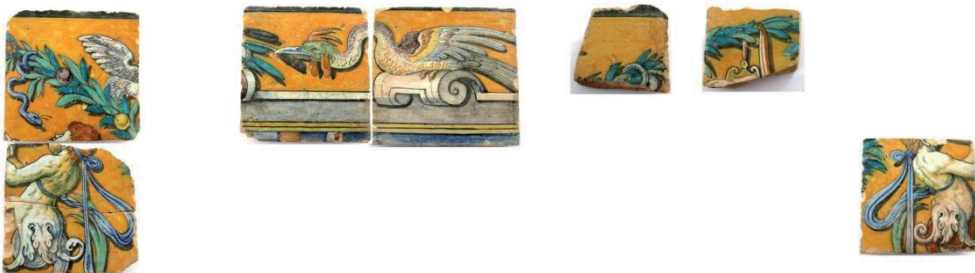


Figure 1a, b, c, d, e, f, g (clockwise left to right): Azulejos and fragments found during an archaeological excavation in Lisbon, in the area of the old *Escolas Gerais*.

Since 2016, excavations in four other sites uncovered more testimonies of the presence of faience azulejos of undetermined origin in Lisbon datable to the second half of the 16th century. One excavation, under the responsibility of archaeologist António Valongo, was in the so-called area of *Largo do Corpo Santo*, near the *Arsenal da Marinha* in Lisbon, once on the bank of the river, from which it is now separated by an embankment, not far from the Royal Palace destroyed by the earthquake of 1755. The findings, once again in the context of a wastetip, stem from an area where, in the 16th century, the most remarkable building was the celebrated palace of the Corte-Real family, built in 1585. At that time in this area there was also a small chapel dedicated to *Nossa Senhora da Graça* which has today disappeared. Being found in a disposal context, it is difficult to pinpoint which building the azulejo finds belonged to, or even whether they all originate from the same place.

Among an impressive array of Italian and Spanish ceramics from the 16th century the archaeologists uncovered several groups of Hispano-Moresque azulejos some of which were only previously known from the Royal Palace of Sintra (figure 2a) and believed to have been a commission expressly made to be applied there. Among other unusual, and in some cases almost unique, pieces there were three fragments of faience azulejos that, although they could be associated to a Flemish origin, may have been produced in Seville or Lisbon (figure 2b, c, d).

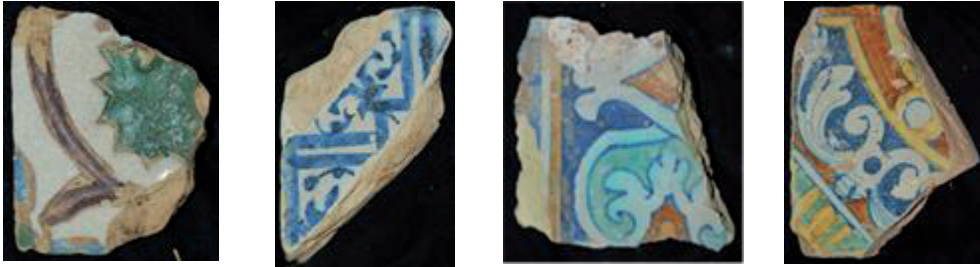


Figure 2a, b, c, d (left to right): Azulejo fragments found during an archaeological excavation in the area of Largo do Corpo Santo in Lisbon. 2a) fragment of a so-called “Parra” tile known to have being commissioned for the Palace of Sintra; 2b) fragment of a patterned azulejo, ca.1560s (?); 2c) fragment of the frame for a panel and 2d) fragment of the framing of an ornamental or heraldic motive (1560s to 1580s?)

One of the pieces (figure 2b) is a fragment of a patterned azulejo that depicted an elaborate composition in blue over the white background of a stylized arabesque surmounting a cross. These motives in blue are related to the compositions that could be seen in embroidery and lace and were popular in Italy (where they seemingly originated) Flanders and Spain. The second fragment (figure 2c) is related to a frame, which in Portugal we call a “cercadura”, its width spanning a single azulejo. This kind of motif has been classified by some authors as being of Moresque taste, reflecting the famed Moorish metalwork. The last fragment may have been part of a composition that framed an ornamental or heraldic motif, hinted by the round element in orange of which a part is discernible and that was commonly used in the composition of portraits or other important decorative elements. From the set found in this excavation this one, albeit rather naively painted, is undoubtedly the most exquisite in terms of the quality of the pigments and the composition depicted, creating a subtle but effective alignment of decorative elements suitable to frame an important central component.

The third site in Lisbon, on an embankment, was excavated by a group whose leading archaeologist was Claudia Manso. It was again near the river but this time on the other side of the grounds at *Campo das Cebolas* where the Royal Palace once stood. Among an astonishing collection of Italian maiolica and Spanish pieces of this period, an important set of azulejos was found, some of them being very unusual (figure 3). Once again, a fragment was found of a type of Hispano-Moresque azulejo only previously known to have been commissioned for the Royal Palace of Sintra, although it had a different aesthetic than the one that appeared in the previously mentioned excavation. Another azulejo found there, was an example of an early piece of faience azulejo, this one being what in Portugal is called a “friso”, a frame whose width is that of half an azulejo or less. Depicting a “laçaria” motive or a twist string related with the Moresque aesthetic, it is of a rather different composition from what usually is associated with Flemish workshops which rooted their designs solely on the renaissance taste. Despite being less perfect in terms of the quality of the drawing, the design is nevertheless difficult to render in the faience technique and the colours are vibrant and attractive.



Figure 3 a, b, c (left to right): Azulejo fragments found during an archaeological excavation in the grounds of the area of *Campo das Cebolas* in Lisbon. 3a) a fragment of a *cuerda seca* Hispano-Moresque tile with a pattern called “pé de galo” known previously only from the Palace of Sintra; 3 b) fragment of a faience *laçaria* narrow frame for a panel, ca.1560-1580; 3 c) floral painting on an azulejo remarkable for the reddish biscuit, a colour often seen in the earliest faience azulejos produced in Lisbon.

The area where the pieces were found is of significance. Near this area stands to this day the famous *Casa dos Bicos* ou *Casa dos Diamantes* (“House of Beaks” or “House of Diamonds”) an Italian-like building that was erected by Brás de Albuquerque, son of Afonso de Albuquerque, the Viceroy who laid the foundations of the Portuguese “India State”. This is an interesting aspect because the same Brás de Albuquerque was responsible for the *Quinta da Bacalhoa*, in Azeitão, a place that is related to very early faience azulejos attributed to the Lisbon workshops [6]. When the remains of his father were brought back from India, they were laid to rest in a mausoleum in the main chapel of *Igreja da Graça*, in Lisbon [7]. In an area of that same church the azulejos signed by João de Góis are set, possibly the earliest tiles known from this time that we can claim to have been made in Lisbon in the faience technique. Although the archeological finds cannot be associated with Brás de Albuquerque, it is certain that he had a taste for faience tiles painted in the renaissance style and his name recurs in the area of the finds in 16th century Italian majolica and azulejos.

Finally, on another archaeological excavation in 2018, led by archaeologist Victor Filipe at a building in *Travessa do Açogue*, where it is still possible to see the remains of the main chapel of the demolished *Igreja de Santo André*, several elements of the building were discovered. Amongst the finds were part of a ceramic floor and six fragments of majolica azulejos, five of which, seemingly from a historiated panel are illustrated in figure 4. A hypothesis is that some of these fragments are the remainders of a now-lost azulejo panel known to have existed in the same church and dated to ca. 1580 [8]. The historic significance of this find will be discussed in a separate paper [9].



Figure 4a, b, c, d, e, f (left to right): Azulejo fragments found during an archaeological excavation in the grounds of the demolished *Igreja de Santo André*. 4a) to 4e) are thought to have been part of an azulejo panel dated ca. 1580 known to have existed in the church. 4f) does not depict the same blue contours and therefore may have belonged to a different panel.

INSTRUMENTAL MEANS

The fragments were sampled by removing small fractions of the glaze with biscuit attached which were embedded in resin and polished for observation and analysis by scanning-electron microscopy coupled with energy-dispersive spectrometry (SEM-EDS).

SEM-EDS observations and analyses were made at the HERCULES Laboratory in Évora using a HITACHI 3700N SEM coupled to a BRUKER XFlash 5010 EDS. The specimens were uncoated and observations were made in back-scattering mode (BSE) with air in the chamber at a pressure of 40Pa and at an accelerating voltage of 20.0 kV.

The back-scattering mode relies on electrons from the incident beam that are back-scattered out of the specimen without losing their initial energy. Since heavy elements (those with higher atomic numbers in the Periodic Table) backscatter more electrons than light elements (those with low atomic numbers), areas with more heavy elements in their content appear brighter (or “whiter”) in a back-scattered image and thus give information about the composition of the specimen under observation. As the glaze of an azulejo has a high lead-content, its image is much whiter than the image of the biscuit that contains mostly low-atomic weight elements such as silicon, potassium, and calcium. BSE imaging is therefore an ideal technique to study the glaze and its inclusions as well as the interface between the glaze and the biscuit.

INSTRUMENTAL RESULTS

Flemish sample from the excavation at *Escolas Gerais*

Tile “boy and snake tile” (figure 1b) was sampled in the off-white area and the item obtained identified as “Az030/A1w”. Figure 5 depicts its section after polishing, both in optical microscopy and as a BSE-SEM image.

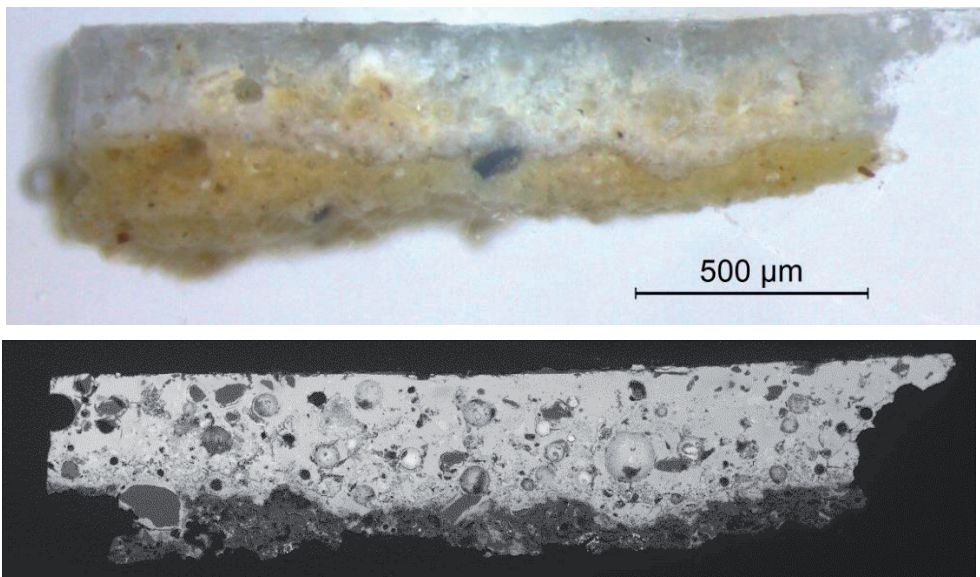


Figure 5: Item Az030/A1w sampled from an excavated 16th century Flemish tile under the optical microscope and the SEM in BSE mode (same scale)

Before the presentation of results and discussion are undertaken, we need to understand that while macroscopically the tile looks presentable, even as a museum item, the consequences of a long burial in an environment with circulation of water can seriously affect it at the microscopic scale and influence relevant information such as the Pb content (lead can easily be lixiviated). Although the style of the decoration leaves little doubt that it is of Flemish origin, there remains the question of whether the workshop that produced this panel is the same that produced the tiles for the Vila Viçosa Palace [10]. We shall try to reply to that question by comparing the excavated tile with item Az031/A, sampled from a fragment of a Vila Viçosa tile shown in figure 6a.

As can be seen, the biscuit in figure 6b is of a homogeneous cream colour and the glaze in figure 6c is clear. In the sample under study the glaze is clouded by lixiviation and/or deposition of acquired chemical species, often alien to the tile, that darken the biscuit and make it less suitable for comparison purposes.

Figure 7 shows a SEM-BSE detail of the glaze of Az030/A1w. The top of the glaze is not perfectly flat because the glaze is flaking off but still its condition is acceptable. Excessive flaking of the surface is a direct clue that the decay has maybe advanced too far. The gas bubbles are not coated in the interior with a white layer- a good sign because when lixiviation attains the bubble area, part of the lead will deposit inside the bubbles and in BSE mode those deposits are seen as a very white lining. Therefore, this particular section Az030/A1w may be analysed with some confidence in the results.

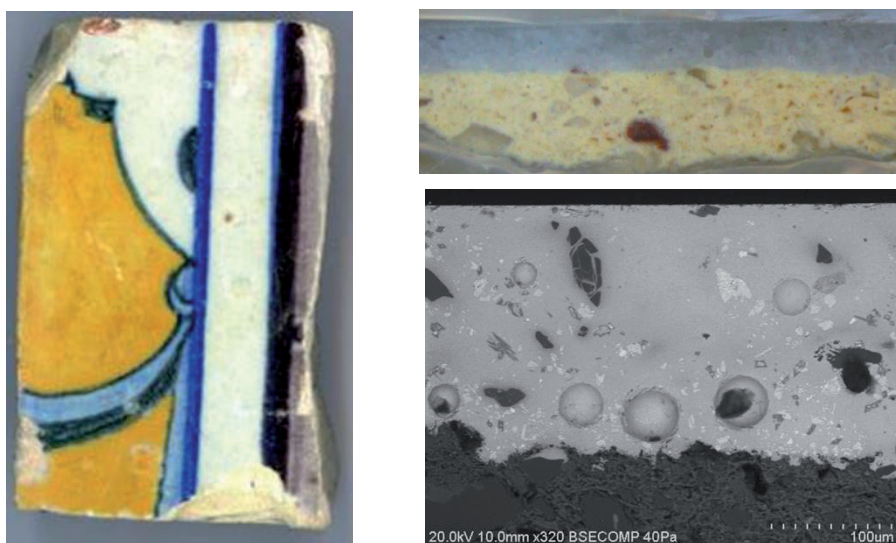


Figure 6 a, b, c (clockwork from left): A fragment from a 1558 Flemish tile from the Vila Viçosa Palace that did not suffer burial and has been preserved in good condition. 6b) optical image of the section of a specimen sampled from the tile and identified as “Az031/A”. 6c) BSE image of part of this section.

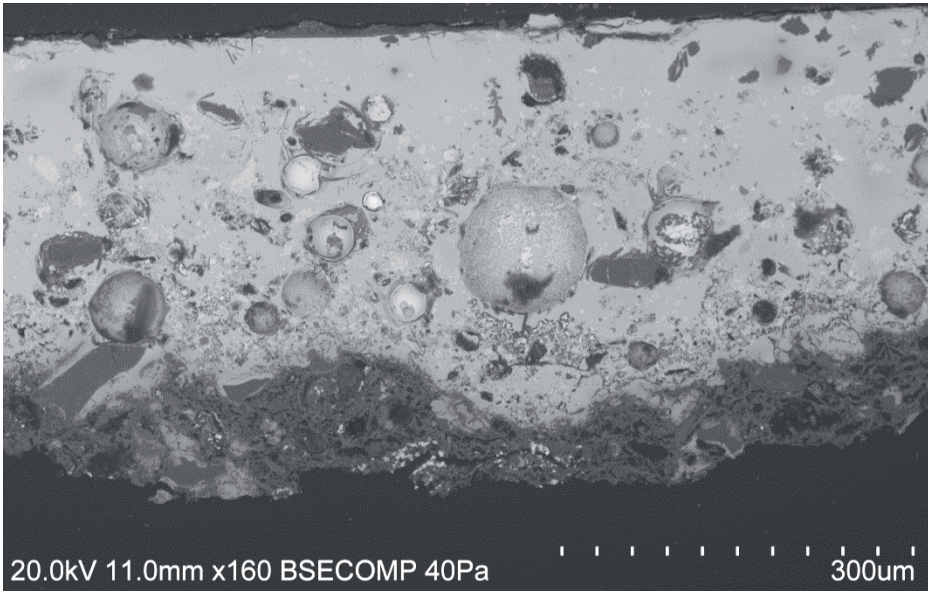


Figure 7: Part of the section of item Az030/A1w. There is only limited flaking of the surface and there are glaze areas suitable for semi-quantification

Figure 8 compares, at the same scale, the interface of Az030/A1w from the excavated tile with Az031/A from Vila Viçosa. This interface is important because its morphology is related with e.g. the duration of the firing cycle. Az030/A1w shows more interfacial crystalline growth than Az031/A suggesting that it may have been fired for a longer period, giving time for the growth of the crystals.

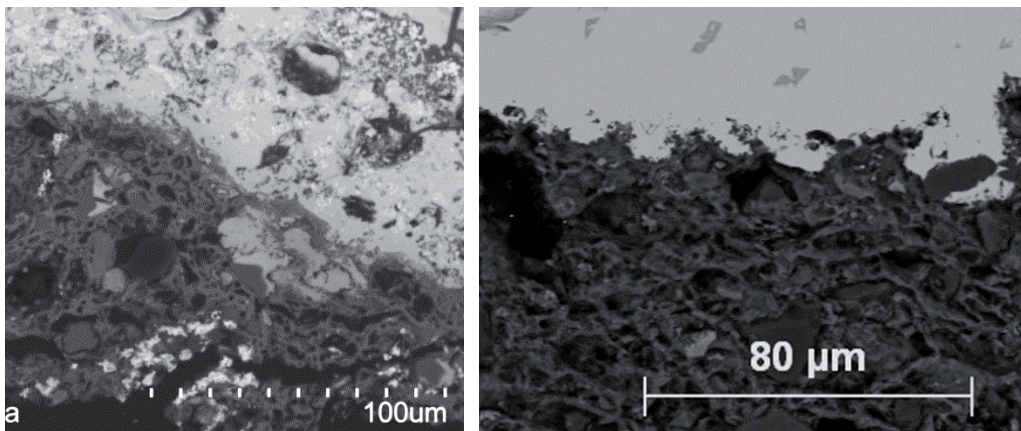


Figure 8a, b: Comparison of the interface glaze/biscuit on Az030/A1w (left) with Az031/A

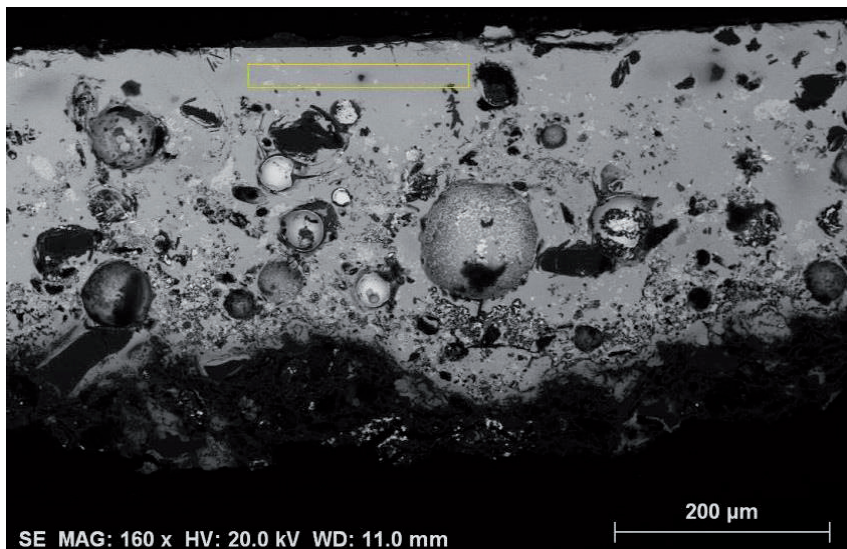
We now turn to an analytical procedure (EDS) to try and compare the composition of the glazes. Figure 9 depicts two glaze areas of Az030/A1w that were analysed and the resulting spectra (taking spectra as fingerprints allows for a simple but quite effective morphological comparison of the results). The first spectrum identifies the relevant peaks and the second, of an area far apart,

is compatible with the first in relation to those elements. If the specimen was too decayed for analysis, the top area would be expected to return different results, e.g. much lower contents in lead, than the area closer to the biscuit.

Figure 10 depicts the area and spectrum of a similar analysis on the Vila Viçosa specimen (Az031/A). It is clear that both tiles are quite different in a composition that may characterize the workshop, because the raw materials for the glaze should be acquired, prepared and mixed according to an in-house own recipe.

The comparison can also be based on the results of the semi-quantification (Table 1) and it is clear that the tile from the excavation has more sodium in the glaze (which might actually be a result of the long burial) but much less aluminium and potassium while the very important ratio Si/Pb, which defines the temperature at which the tiles may be fired, is considerably lower for Az030/A1w than for Az031/A. The burial would tend to lower the content in lead and therefore increase the ratio, not lower it.

This result, advanced as a working hypothesis, is consistent enough to suggest that the tiles excavated originated from a different workshop than those in Vila Viçosa. This is a conclusion of great importance to the technical history of majolica production in Antwerp that may later be strengthened when more instrumental results become available following further study.



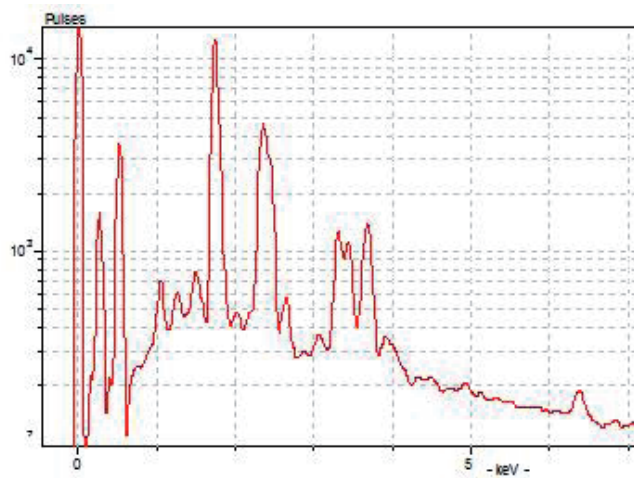
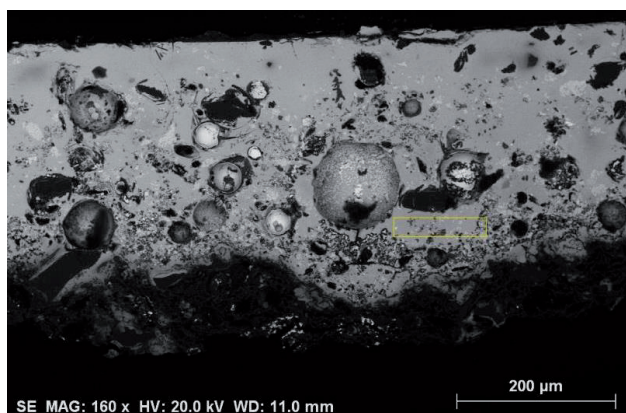
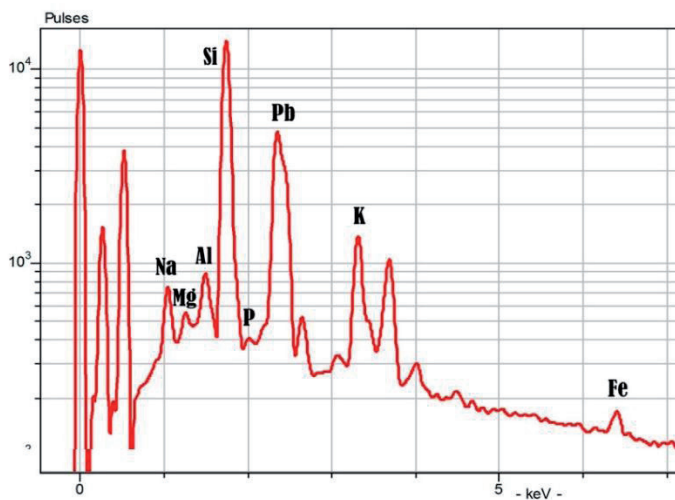


Figure 9 a1, a2, b1, b2 (top to bottom): Two areas in the glaze of Az30/A1w selected for analysis and respective EDS spectra (a2, b2).

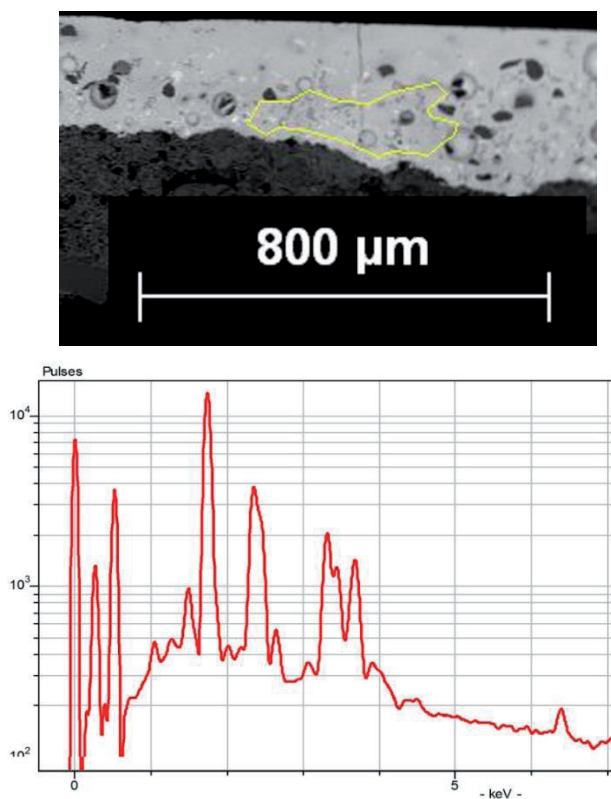


Figure 10: Area of the glaze of Az031/A analysed for comparison purposes, and resulting spectrum.

Table 1: Semi-quantification of the glaze composition in areas of Az30/A1w (see figure 9b1) on the left side of the table and Az031/A (see figure 10)- all values are % wt of the elements

Oxygen	31,12	Oxygen	32,00
Sodium	1,88	Sodium	0,92
Magnesium	0,78	Magnesium	0,44
Aluminium	0,87	Aluminium	1,26
Silicon	18,90	Silicon	20,42
Potassium	3,30	Potassium	5,82
Calcium	3,14	Calcium	2,88
Iron	0,75	Iron	0,74
Tin	7,42	Tin	9,22
Lead	31,37	Lead	26,18
Si/Pb	0.60	Si/Pb	0.78

Faience tile from an excavation near *Largo do Corpo Santo*

The tile shown in figure 2d was sampled and the items obtained identified as Az319. One of them, sampled from the yellow-coloured area, was identified as Az319/02 and a synopsis of the results will be given here.

Figure 11 shows the section of the specimen and, from the BSE image in figure 11b, its condition seems better than that of the Flemish tile discussed in the previous section. However the surface of the glaze, which should be flat, is chipped along its whole length showing that, although not visible to the naked eye, the surface of the glaze is missing almost entirely (figure 12a).

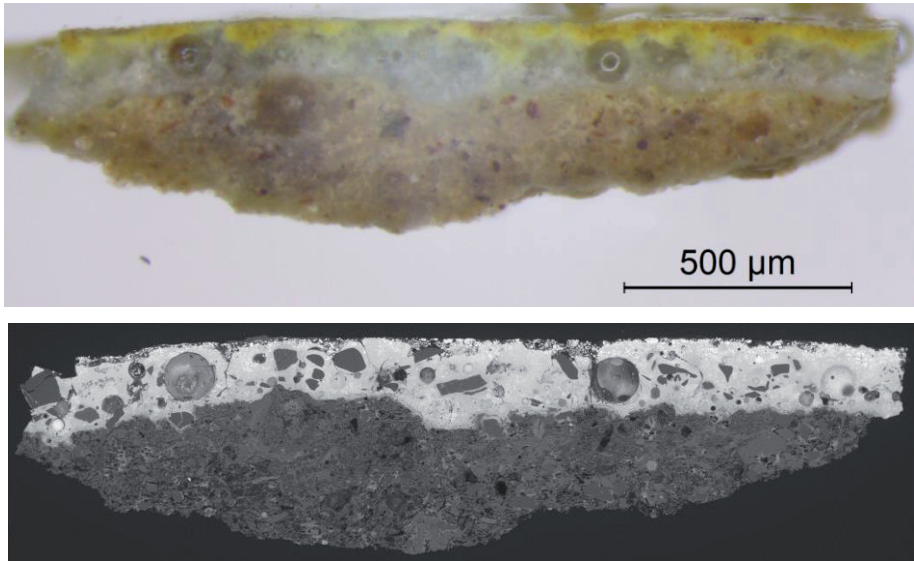


Figure 11a, b (top to bottom): Full section of test item Az319/02 under the optical microscope and the SEM in BSE mode.

Figures 12a) and 12b) show details of the glaze under the SEM in BSE mode. The white specks on 12a) are particles of the yellow pigment used.

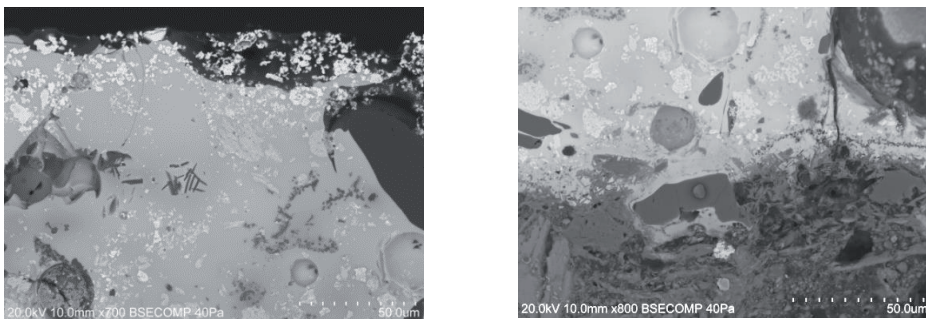


Figure 12a, b (left to right): 12a) Surface of the glaze of specimen Az319/02. 12b) interface between the glaze and the biscuit.

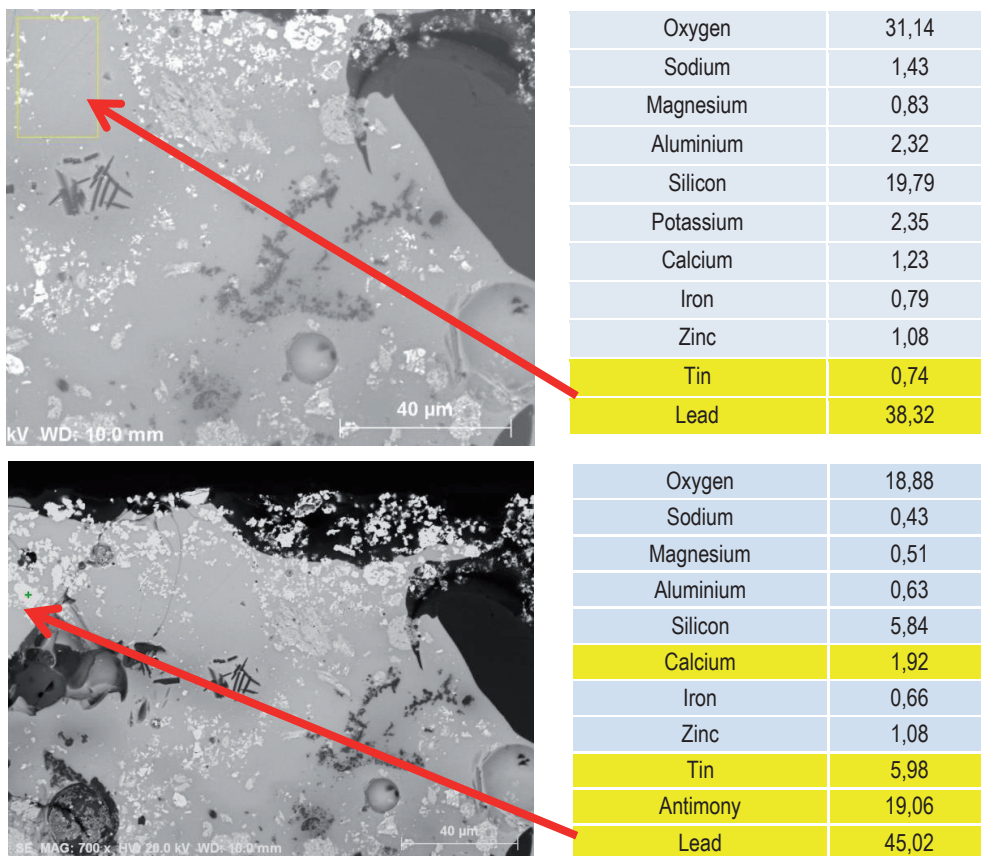
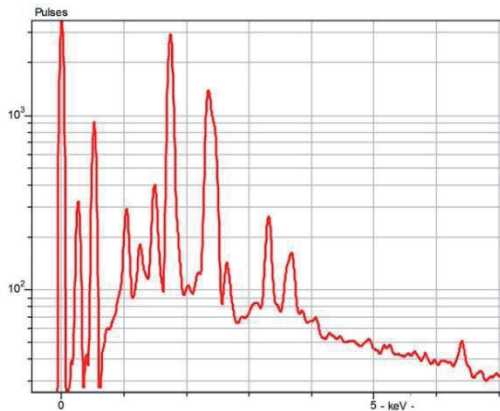
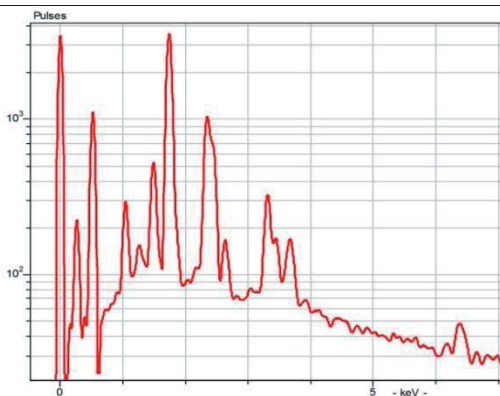


Figure 13 a, b (top to bottom): 13 a) semi-quantitative analysis of the glaze in the section area bearing the grains of pigment. 13b) point semi-quantitative analysis of a yellow grain.

A semi-quantitative analysis of a grain of the light yellow pigment was performed and compared to a similar analysis of the matrix glaze (figure 13- all results are %wt of the elements) showing that the grain has a composition where, despite its incorporation into the glaze matrix, can be recognized as antimony (Sb) and a higher percentage of lead, tin and calcium. This result strongly suggests that the pigment was not the common Pb+Sb Naples yellow but rather a triple Pb+Sb+Sn pigment [11, pps.180-211] to which there is always an associated calcium content. This pigment was also found in the Vila Viçosa tiles [10]. This in no way means that the tile is Flemish since the pigment was imported to Portugal, at least to Lisbon, and has been found in tiles manufactured here, such as the panels of *Igreja da Graça* (to be published). Trying to identify a match between this tile and tiles excavated from different sites, we compared it to the discreetly decorated fragment excavated from *Igreja de Santo André* and depicted in figure 4f. Figure 14 shows that there is a close match in the glazes spectra (these may be compared with the spectra in figures 9 and 10 to see how different they are) suggesting that both fragments may indeed stem from a single workshop or, at least, from the same region, likely Lisbon.



Oxygen	31,14
Sodium	1,43
Magnesium	0,83
Aluminium	2,32
Silicon	19,79
Potassium	2,35
Calcium	1,23
Iron	0,79
Tin	0,74
Lead	38,32



Oxygen	33,38
Sodium	3,13
Magnesium	0,79
Aluminium	3,35
Silicon	20,35
Potassium	3,31
Calcium	0,85
Iron	1,17
Tin	3,84
Lead	29,49

Figure 14a, b (from top to bottom): Comparison of the elemental spectra of the glazes of Az319/02 (the present tile on top) vs. Az 331/06 (a specimen sampled from the tile fragment excavated from far away Igreja de Santo André and depicted in figure 4f).

CONCLUDING REMARKS AND HOPE FOR THE FUTURE

The present communication presents only a limited set of results of the full study that is presently being undertaken. Other 16th century azulejos and faience fragments are being excavated and we will be able to present further interesting examples in the future as a result of our cooperation with the essential work that archeologists are doing. Today these results are attracting more attention and we can see the real importance of these discoveries in the context of the initiation of azulejo production in Portugal, from Flemish roots to Flemish workshop-masters working in Lisbon [12].

However many excavations were carried-out in the past where the information has been lost as we can read in the 1872 testimony by Ribeiro Guimarães: “Mr. José Valentim (to whom we owe the preservation of the 16th century panel of *Nossa Senhora da Vida* that can be seen in the Museu Nacional do Azulejo) stated that at some excavations in the area of Olarias (in Lisbon) he found fragments of azulejos similar in production and painting, colours, etc, to those in the Chapel of Nossa Senhora da Vida. This incontestably demonstrates that in the 16th century the art of [majolica] production had already reached a level of perfection in Portugal” (*O Sr. Jose Valentim nos afirmou que, em umas escavações no sitio das Olarias, encontrara fragmentos de azulejos, eguaes na fabricação, e na pintura, cores, etc., aos da capella da Senhora da Vida. Este facto,*

que é incontroverso, mostra que no século XVI, estava em Portugal mui aperfeiçoada a arte de oleiro) [8].

Well, we hope that many interesting azulejos, long lost in depots and archives of excavation finds, can still be dug out once again from their resting places and brought to light to be identified and studied in order to bring a more complete understanding of this exciting period of less than three decades that started a course of events that lead to the flourishing art of the azulejo in Portugal.

Acknowledgements

Communication produced as an outcome of Project FCT-AzuRe - Estudos no Azulejo Português para Candidatura a Património da Humanidade (PTDC/EPH-PAT/5096/2014) funded by FCT, the Portuguese Foundation for Science and Technology.

LNEC Research Project 0202/111/19747

Bibliographic references

1. HALLETT, Jessica, SENOS, Nuno, *De todas as partes do Mundo. O Património do 5º duque de Bragança, D. Teodósio I*, Lisboa, Tinta da China, 2018.
2. *Da Flandres. Os azulejos encomendados por D. Teodósio I, 5º Duque de Bragança (c.1510-1563) | From Flanders. The azulejos commissioned by D. Teodosio I, 5th Duke of Braganza (c.1510-1563)* (cat. exp.). Lisboa, Museu Nacional do Azulejo | Museu-Biblioteca do Paço Ducal de Vila Viçosa, 2012.
3. ARCH. TORRE DO TOMBO, Processo de João de Góis (29/07/1561 - 08/02/1562), proc. 6820. Tribunal do Santo Ofício, Inquisição de Lisboa, processos (1536-1821), (1561/1562).
4. RIBEIRO, Inês, POLICARPO, Raquel, CASTANHEIRA, Inês, *Reabilitação de um edifício sito na Rua Guilherme Braga nº 16-20 e Rua das Escolas Gerais, nº 45-47, em Lisboa*, (relatório policopiado). Lisboa, ArchBiz, Arqueologia Empresarial, January 2013.
5. DUMORTIER, Claire, *Céramique de la Renaissance à Anvers: de Venise à Delft*, Éditions de l'Amateur, Bruxelles, Éditions Racine, 2002.
6. SANTOS SIMÕES, João Miguel dos, *Azulejaria em Portugal nos séculos XV e XVI*, Corpus da Azulejaria Portuguesa, Lisboa, Fundação Calouste Gulbenkian, 1969.
- 7 BAIÃO, António, *Alguns ascendentes de Albuquerque e o seu filho à luz de documentos inéditos. A questão da sepultura do Governador da Índia*, Coimbra, Imprensa da Universidade, 1915
8. GUIMARÃES, Ribeiro - *SUMMARIO DE VARIA HISTORIA. Narrativas, lendas, biographias, descrições de templos e monumentos, estatísticas, costumes civis, políticos e religiosos de outras eras*, Rolland & Semiond, Lisboa, 1872, vol. II, p. 107.
9. PAIS, A. et al. - *The lost azulejo panel once in the Church of Santo André, near Graça, in Lisbon* in Proc. GlazeArt 2018, LNEC, Lisbon, 2018.
10. MIMOSO, J. et al. – *Analytical study of tiles of presumed Flemish origin from the Palace of the Dukes of Braganza in Vila Viçosa*, in “From Flanders. The azulejos commissioned by D. Teodósio I, 5th Duke of Braganza Museo Internazionale della Ceramiche, MNaz & Fundação da Casa de Bragança, Lisbon 2012, pps. 64-74.
11. SECCARONI, C. – *Giallorino- Storia dei pigmenti gialli di natura sintetica*, De Luca Editori D'Arte, Roma, 2006, pps 78-90 & 180-211.
12. PAIS, A. et al. – *Graça Church Revisited* in Proc. Int. Conf. Glazed Ceramics in Cultural Heritage (GlazeArch2015), LNEC, Lisbon.

Conservation and restoration of the tile collection of Quinta Nova, Torres Vedras - Criteria and technique

Ricardo Triães

Techn&Art - Technology, Restauration and Arts Enhancement Centre, IPT, Quinta do Contador, Estrada da Serra, 2300-313 Tomar, Portugal, rtriaes@ipt.pt

Ânia Chasqueira

Techn&Art - Technology, Restauration and Arts Enhancement Centre, IPT, Quinta do Contador, Estrada da Serra, 2300-313 Tomar, Portugal, al.chasqueira@gmail.com

Catarina Melo

Techn&Art - Technology, Restauration and Arts Enhancement Centre, IPT, Quinta do Contador, Estrada da Serra, 2300-313 Tomar, Portugal, catarinamelocoelho@gmail.com

SUMMARY: The work of recovering a vast collection of tiles from Quinta Nova, Torres Vedras, has been the subject of study and intervention of conservation and restoration in the Laboratory of Conservation and Restoration of the Polytechnic Institute of Tomar. The collection is very diversified, both in stylistic terms and chronologically, being able to find pattern tiles of the 17th century, figurative tiles from the first half of the 18th century, as well as pattern tiles of single figure and “pombalinos”.

With the exception of a tile panel still in situ, but not in its original place, the remaining tiles were displaced, some in later reapplications, and the majority in boxes without any reference as to the place of provenance or position.

The fact that they have been removed without any care has caused huge problems for their conservation, since in addition to being a large collection and in need of triage and inventorying, there is also a very significant group of fragments.

So, the work developed consisted in the definition of an intervention methodology that allowed treating all the collection. The poor state of conservation of some of these elements has put a series of challenges that have led to the search for some creative solutions for its conservation. The methodology used was aimed at recovering the meaning as an image, although with very different results, both due to the state of conservation presented and the technique used. In the case of panels with gaps and lack of tiles was used the "hot" restoration technique. For the tiles without any reference and for the fragments, a different methodology was followed, preserving them in a creative way, by juxtaposing the various elements according to a previously defined design, preserving their historical-artistic value but creating new readings. These solutions are effective, in particular in how they conceptually address the problem of the conservation of very incomplete tiles, are compatible, reversible and still allow enjoying them.

KEY-WORDS: tile, displaced heritage, creative conservation

INTRODUCTION

The House of Quinta Nova, from which all or almost all of the tiled estate is tested, is located in the parish of Matacães, municipality of Torres Vedras. It is classified as a property of municipal interest through Decree-Law no. 2/96, of Diary of the Republic no. 56, dated March 6, 1961. It has a long, L-shaped sober facade whose chapel shows the coat of arms of the family [1]. The configuration of the current building is expected to be in the last quarter of the 18th century, judging by the date inscribed on the facade of the chapel attached to the house, 1779. This will most probably be one of the last great transformations of space, year of 1777 one already has a reference to House of Quinta Nova, mentioned in a particular document [2].

Most of the tiles have been removed in the 60's during the works of remodelling of the space, resulting in a very careless intervention that led to the irreparable loss of several panels.

The materials identified range from 17th-century pattern tiles, figurative panels from the first half of the 18th century, “Pombalino” pattern tiles, single figure tiles, to white tiles, probably kitchen spaces or service areas.

Of the removed tiles, those that were in good condition, were later reused, namely the pattern tiles, white tiles or frame elements. Most of the bars, more composite, and the entire figurative tiles were stored, many of them still with large quantities of mortars on reverse to be cleaned. Only one of the panels was recently removed in 2011 for security reasons and for prevention of possible theft or vandalism, considering the state of abandonment of the site. This survey was carried out according to a methodology that allowed the correct identification of the tiles and their removal without causing significant damage [3].

THE TILE COLLECTION OF QUINTA NOVA

Under a protocol between the Polytechnic Institute of Tomar (IPT) and the owner, most of the collection was received at the premises of the Laboratory of Conservation and Restoration (LCR.IPT) for future intervention. The tiles of the figurative panel raised in 2011 were the target of intervention during a master's degree as well as during conservation and restoration of ceramic materials of the degree in Conservation and Restoration. The fragmented tiles were only stored without any intervention. After the conclusion of the intervention of the figurative panel, the first work of triage the fragments were started, separating them initially by styles, decorative motifs and colours.

The oldest motifs identified in the set of fragments belong to 17th century pattern tiles, essentially in blue and yellow and are easily identified different types of decorations [4].

As for the tiles of the beginning of the 18th century, we can divide into two types: 1st - the tiles belonging to the initial phase of the production of baroque tile begun through a group of painters who made the transition from the late 17th century to the early 18th century [5], painting decorative scenes in blue and white with double bars of vegetal elements, atlantes and angels; 2nd - figurative panels of the “Joanino” period, where we can identify, among others, some scenes of courtesan and hunting [6]. With the exception of the panel removed in 2011, quite complete, the remaining panels identified are very mutilated, and in some of them only a few units were identified.

From the second half of the 18th century we can frame the “Pombalino” style pattern tiles and single figure, composed exclusively of flowers.

It is still possible to identify some tiles from the late 18th or early 19th century, of neoclassical style, probably used in foothold areas or in small panels. Many fragments of white tiles have also been collected, certainly used in kitchen areas or other services.

Intervention criteria and methodology

Considering the diversity of styles, periods and state of conservation of the tiles under study and intervention, an approach to the estate was adopted that allowed defining the criteria and solutions for each panel/set and defining the intervention methodology. It is also important to note that the various interventions carried out on the estate were always carried out in the context of the students' training, whether in class, academic internship or workshop.

The panel, which was still in situ and was removed, dates back to the first quarter of the 18th century and consists of 3 mythological scenes from Perseus and Andromeda and the legend of Apollo and Daphne. The third smaller scene represents the dramatic episode of the relationship between Pyramus and Thisbe (Figure 1) [3]. The damages identified in the panel have diverse origins, from the manufacturing problems to the result of the anthropic action. The panel was in a distant area of the house, in an old garden area, near the edge of the property which motivated its removal for fear of theft or vandalism. The panel presented some problems such as lack of tiles, replaced tiles, loss of cohesion of the mortars, detachment tiles, and dense vegetation. The tiles also presented several manufacturing defects, structural cracks, fractures, gaps, glazing failures and detachment glaze, surface deposits and an intense biological colonization in the areas of glaze loss [7, 8].



Figure 1: The different scenes of the panel that was still in situ.

The remaining set in intervention was in two different situations, determined by its state of conservation. It is not sure that all the collection has the same provenance, that is, of the Quinta Nova house, but at least most of it will have had that provenance. The whole tiles were mostly stored in the residence of the owner, some of them, especially the patterned ones, used in the decoration of the garden spaces or inside the residence. The tiles that resulted from the demolitions of the walls of the House of Quinta Nova and which were fragmented were relegated to a warehouse on another property, resulting in construction rubbish.

This set of fragments was completely collected for the facilities of the LCR.IPT in order to the practice of conservation and restoration in ambit of classes. The whole tiles, essentially of a figurative type, bars and tiles from “albarradas” were also gathered in the same premises in order to establish a triage and to perceive the set in question.

These tiles, many of them still to be cleaned, there was a need to remove the mortars from the reverse and through the marks of position it was possible to recognize until the moment, tiles belonging to 18 different panels and of different styles.

The marks that identify these panels revealed the existence of very few pieces for most cases. There was only one case where the number of existing tiles was more than half the totality of the panel and in this case it was selected for intervention during the master’s classes in the tile specialty. In the case of fragmented tiles it was also possible to carry out a triage by separating the fragments by decorative typologies, styles or colours. From this set of fragments was also

carried out a methodological approach with different purposes and techniques in order to generate an impact and a reflection on the conservation of this type of collection.

Figurative set "in situ"

Afterward the survey, during the cleaning and reorganization work of the panel it was possible to notice that the frame that surrounds the scenes did not originally belong to the panel or at least in its original layout. After the identification of the marks of the reverse of the tiles, where two different types of markings could be read, the original one in blue and a second one, coarser, in red, realized in way to integrate the bar with the figurative panel facilitating its application.

Given a set of evidence it became clear that in addition to the bar did not belong to this panel or, at least, was performed separately, and the replacement of the set left some tiles out, which is apparent from their adaptation to this new space [3].

The calligraphy between the tiles of the bar and the figurative panel allowed observing some differences that lead us to believe that they will even have different individuals to mark them. These differences are obvious in b, f and 8 (Figure 2). Although the 8 is very similar, one is the mirror of the other, being that of the two painters' one could be right-handed and the other left-handed.

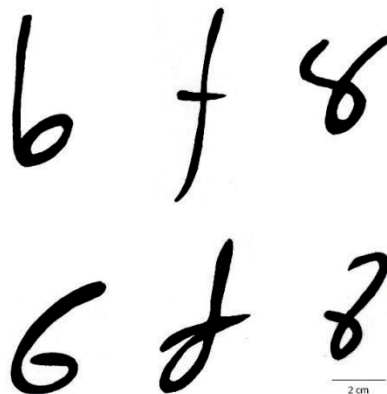


Figure 2: Examples of the different types of calligraphy in the panel.

These characteristics that we identified in the panel about its execution and application (certainly not original), the state of conservation, the interest of the owner in exposing the panel in a new place and the reflection on the intervention methodology to be adopted led to the conservation and restoration of mimetic type (Figure 3). The glaze loss was punctual and only in some tiles, and whenever the formal continuity of the design did not allow its reconstitution, it was not forced reintegration. Only in very specific cases were new tiles made, following the same criterion of reintegration, and identified the new pieces. The panel was assembled on acrylic supports in an interior space, maintaining the configuration at the time of removal, and preserving the only known application and avoiding the filling of significant faults of tiles that were observed [7]. Although the character of the intervention was not only conservative, respect for the principles of minimum intervention was always present, namely in the chromatic reintegration of the lacuna areas.



Figure 3: Panel after conservation and restoration with mimetic reintegration.

Figurative panel

The tiles of this panel were stored in one of the houses of the owner, and some fragments to this set were collected from the fragments in storage in the IPT. From a stylistic and technical point of view it fits into the tile production of the “Joanino” period, also called the “Great Production”, corresponding to the 2nd quarter of the 18th century. It is a motif with a central fountain and at least three male figures that bathe there, an aristocratic couple on the right and left two gentlemen, one of them playing a violin (Figure 4).

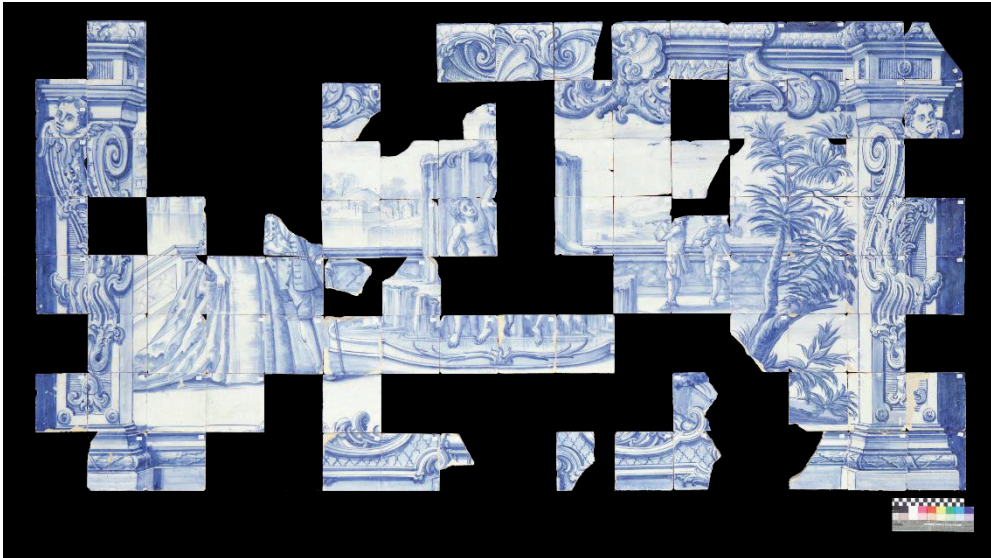


Figure 4: Figurative panel of Quinta Nova before intervention.

Originally the panel would consist of 128 tiles, currently only 91 tiles or fragments remain. The original location of this panel is unknown but it is known that they once belonged to Quinta Nova. In addition to the significant number of missing tiles, there are several fractured and lacquered tiles as well as glaze gaps, surface deposits, mortar remnants and biological colonization. During the process of sorting the set it was possible to find some fragments that were integrated in the panel. This aspect is relevant because it allows concluding that the provenance of the panel is common with the remaining set of fragments that are known as House of Quinta Nova.

Through the study of the marks of the reverse it was possible to identify other identical panels, with the same type of graphics, and also in the decorative motifs, namely the frame that fits the scenes. In addition to the panel with number 10, tiles with the numbers 4, 5, 6, 7, 8 and 9 were also registered, although they are smaller in number than the previous one. Due to the high number of missing tiles and no concrete place for their application, and the existence of more

panels with the same theme, the chosen methodology that essentially intends the conservation of the tiles.

In this way, none of the interventions aimed at the application of any action on the tiles that involve its reconstitution. In the areas corresponding to the missing frame, and whenever possible, given the symmetry of the decorative motif, a reproduction was performed. In the remaining cases the lack of tile was only filled with a tile with the base shade of the glaze. The filling of the tiles was done by the "hot" technique [9], while maintaining the shade of the glaze without any draw (Figure 5). In this way, if new fragments arise, it becomes easy to integrate them in the panel without resources to any more invasive action.



Figure 5: Figurative panel of Quinta Nova after intervention.

Tile of single figure

The tile of a single figure, also present in the collection of the House of Quinta Nova, which appears in the end of the 17th century, through the Dutch tiles. In this set only a later decorative type is identified, which repeats only the motif of a flower with several configurations (Figure 6).



Figure 6: Single figure panel with flower motif.

After the selection of all the fragments with this decorative motif, the triage was carried out in order to identify the fragments of a single tile. Following this methodology, it was possible to reconstitute several tiles. Some of these were complete and for the rest it was tried to make sure that the remaining fragments were not found in the existing collection. Considering the decorative motif of the tiles, although similar, but always different, it was decided not to perform the reconstitution of the decoration. In this sense, the intervention option was reconstituted through the "hot" restoration, maintaining only the opaque white glaze shade. Once again this option responds to the ease of removal of the intervention in the case of an eventual recovery of the missing fragment and, on the other hand, no progress is made with any reconstitution of the decorative motif. In this way, even if we do not retrieve the motif, the simple filling of the gap areas allows us to improve the reading of the set through the chromatic and material continuity (Figure 7).



Figure 7: Single figure panel with flower motif after intervention.

Tile panel "tree"

Of the set of existing fragments, a significant part corresponds to white tiles, the tiles painted in blue, resulting from bars, beams and others not defined and marbled tiles to manganese and blue. Also part of the set are fragments of figurative panels, but were rejected because they could integrate a panel in the future.

After the main triage we realized the existence of many tiles, more or less complete, without any marking and without any correspondence with some identified panel. Thus, since it was impossible to integrate them in their original set, and no other integration possible, it was intended to preserve their aesthetic function as a single element through the creation of a new panel.

In this way it was possible to preserve the tiles, establishing the proper conservation and restoration methodology, removing the old mortars from the reverse, fixing occasional glazing in detachment and consolidating some tiles that were more friable. At the end, a thin layer of reversible adhesive was applied, which in the future allows a more efficient removal of the materials used for its application.

Its arrangement was made by giving the general appearance of a stylized tree (Figure 8), but without ever questioning the stability of the tiles. Thus, although not recovering the original motifs, the set can resume its aesthetic function that otherwise would also be lost with time.



Figure 8: Panel “tree”.

Panel of fragments "Tile of single figure"

In this set only fragmented tiles were used in which the possibility of recovery of their function is hopelessly lost. Not only because they are fractured, but because of the combination of factors such as the lack of knowledge of the original location, the type of framing they provide and the almost certainty that this set constitutes only part of the original panels.

The impossibility of performing a conventional triage, in light of the above, boosted the development of an unconventional project. Starting from the set of tiles described, a methodology was applied common to the conservation of tiles, passing through the cleaning and removal of old mortars and punctually to the fixation of glazes in detachment. At the end, a thin layer of reversible adhesive was applied, which in the future allows a more efficient removal of the materials used for its application.

Starting from one of the tiles of the ensemble, a fragment of tile of a single figure (Figure 9), its draw was reconstituted. This draw was enlarged and transposed to the wall with the final dimension of approximately 3x3m. In this way was recreated a large single-figure tile executed exclusively with fragments.

This project allowed to involve several students in different phases of their formation in conservation and restoration and to contribute to the technical learning, team work and sensitization for the need of protection of the patrimony not only after its degradation but in the creation of mechanisms of prevention and maintenance [10]. The final result combined creativity and technique and allowed to create a panel of tiles that will be used as a way of raising awareness of the need to preserve cultural heritage (Figure 10).



Figure 9, 10: Tile through which the panel was created. Panel of fragments "Tile of single figure".

This unconventional approach in the area of Conservation was motivated by the absence of solutions other than their packaging and storage, at best. The impossibility of reconstituting any panel in its original situation, but never losing sight of the respect for the ethical and deontological principles of the profession of conservator-restorer, not only the fragments, but also the techniques and materials used did not alter the original characteristics of the same and respecting the changes and damages suffered over time.

This work is also the result of a project initiated in 2012 at the Polytechnic Institute of Tomar designated as "Creative Conservation" [11] and whose objective is the valuation of the heritage; respect for materials and production techniques assuming their degradation; the practice of conservation and restoration and the promotion of the integration of the young students in the area, attending to the greater creative and action freedom; to intervene in patrimonial assets without artistic or cultural value considering the state of degradation that they reached or on goods with industrial or technological value; develop artistic creativity through exhibitions or installations promoting the conservation of materials and the preservation of heritage.

CONCLUSIONS

The collection of tiles from the House of Quinta Nova has allowed over the years to build a project that involves several aspects common to the development of conservation and restoration, not only in its technical aspects, but also in the methodological approach. On the other hand, the development of students' techniques and learning based on practical cases, a reality increasingly rooted in the development of polytechnic higher education, is also a target for innovation and opportunity for growth of the students involved. The methodological approach of more conventional teaching is complemented by new proposals that integrate different levels ranging from practice to reflection.

From a more practical point of view, the definition of a methodology about a collection that is unusual and apparently not very stimulating, has demonstrated that its complexity is also a reason for theoretical development through the search for practical answers. The acquisition of skills and the enrichment of the curriculum of the students in the classroom context is also a space for reflection and opportunity to generate new situations.

Finally, the conservation and restoration of such a diversified collection, in a very complex state of conservation, was the reason for seeking adequate responses to each situation. Treating such different situations in the same way would be at all avoidable. On the other hand, the state of conservation of some fragments out of their context, in many situations, would have been sufficient reason for the abandonment of any proposals for intervention. The project "Creative Conservation" also has the merit of presenting a new proposal, which, although it does not solve all the questions, presents a simple working methodology that generates empathy among the group and creates an emotion in the observer in order to expose in a deeper way, about the need to preserve cultural heritage, identity and memory.

Bibliographic references

- ¹ AZEVEDO, Carlos e GUSMÃO, Adriano - *Monumentos e Edifícios Notáveis do Distrito de Lisboa*. Lisboa: Junta distrital de Lisboa, 1963.
- ² MORATO, Francisco Manuel Trigo de Aragão - *Memórias de Francisco Manuel Trigo de Aragão Morato*. Coimbra: 1933.
- ³ ESTEVES, Tânia - *Painel de azulejos da Quinta Nova, Tomar*. Relatório de estágio apresentado ao Instituto Politécnico de Tomar para obtenção do grau de Mestre em Conservação e Restauro. Tomar, IPT, 2011.
- ⁴ SIMÕES, J. M. dos Santos – *Azulejaria em Portugal no século XVII*. Fundação Calouste Gulbenkian, Lisboa, 1971.
- ⁵ CARVALHO, Rosário - *A pintura do azulejo em Portugal [1675-1725]. Autorias e biografias - um novo paradigma*, Tese de doutoramento, FLUL, Lisboa, 2012.
- ⁶ SIMÕES, J. M. dos Santos – *Azulejaria em Portugal no século XVIII*. Fundação Calouste Gulbenkian, Lisboa, 1979
- ⁷ ESTEVES, Tânia, TRIÃES, Ricardo, COROADO, João e ROCHA, Fernando - *Estudo e intervenção de conservação e restauro do painel de azulejos da Quinta Nova - Torres Vedras*. In Actas do Azulejar, Congresso Internacional, Aveiro e Ovar, 2012.
- ⁸ TRIÃES, Ricardo, SANTOS, Luis, COROADO, João e ROCHA, Fernando – *Deterioration of the “Quinta Nova, Torres Vedras” wall tile panel - an analytic approach*. News in Conservation, 41, 2014, p. 7-11.
- ⁹ ESTEVES, Lurdes e SILVA, Teresa - *O restauro de azulejos com fragmentos cerâmicos: uma técnica desenvolvida no Museu Nacional do Azulejo*, In Actas do Azulejar, Congresso Internacional, Aveiro e Ovar, 2012.
- ¹⁰ LOUREIRO, Leonor, TRIÃES, Ricardo e FALCÃO, Cláudia. – *Educational tools for involving higher degree students within the Project Creative Conservation*. New Trends and Issues Proceedings on Humanities and Social Sciences, 8, 2016, p. 32-40.
- ¹¹ TRIÃES, Ricardo, FALCÃO, Cláudia e LOUREIRO, Leonor – *Conservação criativa, Edifícios e vestígios – Projecto-ensaio sobre espaços pós-industriais*. Inês Moreira (ed.), INCM, 2012, p. 216-223.

Lookouts and outlooks: Lisbon, tiles and topography

Helena Cunha Lopes

Art History researcher, Municipal Council of Lisbon City, Portugal, helena.lopes@cm-lisboa.pt

Rui Matos

Art History researcher, Municipal Council of Lisbon City, Portugal, rui.matos@cm-lisboa.pt

Joaquim Marcelino Santos

*Architect, PhD, * Prof., Municipal Council of Lisbon City, Portugal, joaquim.santos@cm-lisboa.pt*

**Tampere University of Technology, Faculty of Architecture, Tampere, Finland*

Lusíada University, Lisbon, Faculty of Architecture and Arts (UL)

CITAD, Research Centre for Territory, Architecture and Design (UL)

SUMMARY: Reading cities and landscapes inform critical natural events that may characterize either environments. The hilly character of Lisbon demands an accurate sense of the natural versus the artificial, to reveal the natural environment under the metamorphosis of the human will.

The rehabilitation of the historical lookouts seems to be a task that must stem from other urban projects that are intrinsic to the city. Thereby, developing a contemporary image that frames past-present-future in the long continuum of artistic, architectural and urban heritage.

KEY-WORDS: tiles, heritage, rehabilitation, lookout, Lisbon.

INTRODUCTION

The aesthetic experience of Lisbon implies certain degree of sensibility that focuses on tiles – *azulejos*. And tiles may perform remarkable differentiated rules regarding the intrinsic context that they form with the materiality of buildings, walls and spaces. *Azulejos* may behave as “ornamental cladding”, structural surface constructors, trompe l’oeil, ornament and last but not least, a fundamental framework for the city in which lookouts and their small, sensitive and intimate gardens play a strong role in order to portray the image of Lisbon.

The aim of this paper is to stress the importance of these essential lookouts from which the materiality of tiles is perceived together with other materialities, where the reflection of the Tagus mingles with the reflection of tiled surfaces, where colours meet. Recent rehabilitation of these public spaces establishes the importance of tiles afresh and motivates a reflection on the way the city shares its identity with the cultural identity of tiles. From white-blue to the polychromatic, Lisbon combines the revelation of tiles. This is only a particular layer of the city’s identity, with layers of the interiors of buildings that await other reflections.

METAMORPHOSIS ON TOPOGRAPHY

The aesthetics of environment as we experience and conceive today is particularly new and that would not come to a Greek, Roman or Renaissance mind. An the same seems true for the experience of the city scape. To experience the environment for aesthetic purposes alone is an idea that comes from the nineteenth century and meant a new approach to nature. Walking ten,

twenty, forty kilometres within nature for aesthetic purposes would not come to an earlier mind. Furthermore, even for scholars, early experiences of nature meant acquaintance with the *geometrico-mathematization* of the *origo rerum* and thus *summa rerum* – we may emphasize – would have been a sign that rational mind may avoid. In this sense, Leonardo da Vinci's drawings are scientific investigation insofar as they also avoid the subjective life of the senses. From the anatomic drawings to mountains to whirlpools, or to explosions, the same ideas are valid. The whirlpool is nothing but the anatomy of water under precise conditions and one needs to inquire beyond the what surface tells us.

But from this moment on image will be understood as the accurate tool to ground both art and science. This is true of Modern Science or of contemporary science and the never-ending debate between the figurative and the abstract is necessarily image centred. What an image may convey, or may not convey, what the limits of the transmission of value and of interpretation are thus prosperous and extend to the *un*-limited limits of human creation.

From its outset, *via moderna* created representations of the city as the ideal city. Under Federico da Montefeltro's reign between 1444 and 1482, in Urbino, marvellous images of the city were created, which certainly had an emphasis on the *geometrico-mathematical cosmos* that would make all that is seen beautiful. In this sense, those paintings represent a first approach to the city in that it should be a beautiful human creation and thus should be experienced and they share the geometrical accuracy of the representation of complex solids found in the intarsia panels of Montefeltro's palace in Urbino. The image must be built according to precise rules because art is scientific and aims at a perfect representation of the world. Actually, as we move from the early Renaissance to Mannerism, much of Philosophy, Theology and aesthetics stems from the problem of image *versus* word. For example, during the early Renaissance, say at a dinner at the Montefeltro's *palazzo*, the scholar who would declaim Horatio and would be familiarized with Roman maxims would have been more highly considered than a painter or a sculptor.

Yet, those paintings of the city avoid the problem of topography and they represent a flat land of the same type as that of the fortress town of Palmanova and yet from primitive settlements to the classical age, topography was both challenging and efficient regarding human safety and a strong functional organization seemed to be a primary issue. Thinking historically, the acceptance of the flatness of Palmanova implied the acceptance of the reducing topography to the walls of the fortress and in this sense, all that can stand for natural became full artificial. Naturally there is a growing complex way of regarding the functional city because all systems of wall-shape meant a precise defence strategy based on given technological means. That is, of the most critical point that the city could be taken to, there were not many ways of using the city by a single one. Thus, the flat city may symbolize a stronger ability to modify the topography than a hilly settlement.

Sometimes, like in Ancient Miletus, we find an accurate approach to topography that combines a symbolic philosophy with a perfect functionalist construction. This approach to place tells us that from early ages the metamorphosis of the natural into the artificial could be taken to a large extent by combining the physical and the metaphysical and for these to be experienced as a certain degree of collage. This contemporary reading is suggested due to the windows that Cubism has opened to our aesthetic perception. That is, our contemporary way of experiencing places has become highly complex.

Yet the topography of Ancient Miletus was not so challenging as that one of Assos and the problem arises from what a particular civilization at a particular time really aimed at. Sacred spaces and their building as well as public spaces and buildings are more demanding in terms of organizing a suitable site in pursuit of specific ends. In general, they were oversized compared to the scale of housing, except for villas or palaces. The vernacular structure is small in terms of its singular unity despite the fact that it can cover large extensions of land. Thus, the idea of the artificial horizontal terrace grounded in walls has been established as a major device to articulate

functionality and symbolic needs. And the concrete that made cryptoporticus possible informed about the extent of the possible metamorphosis of the natural topography versus artificial topography.

The proximity between the Roman Theatre of Lisbon and the Júlio de Castilho Garden (1929) combines a proximity of the physical space itself but also a proximity of millennia. At the time of its glory, the Roman Theatre was certainly an impressive lookout combining two different approaches to topography, the structure of the slope and the facilities of the cryptoporticus. Thus, in a similar way to other civilizations originally rooted in the Mediterranean, we find in Lisbon a relation between the natural and artificial topography that is a cultural construction. The way how we perceive land-river-sea-sky is thus a cultural construction made from two different bases. The first is the general form of the city and the second consists of the places that were developed spatially to be lookouts even if formerly there was also a functional structure behind it such as knowing where boat and ships were entering the Tagus.

The lookouts of Lisbon are, basically, cultural constructions and they illustrate that construction from a chronology of space and time. Perhaps, the most radical one is that embodies the most extended cultural construction itself is the Saint George Castle lookout – a perfect metamorphosis in space and time. The aim of terraces above the walls was not to fulfil an aesthetic requirement when they were built. They objectively represented safety, defence, functionality. Thus, from that early stage until the time when they became spaces of permanence to experience the whole natural-artificially wide scale environment, aesthetically we needed to go through millennia. In this sense, a lookout of this kind roots Lisbon to early stages of classical civilization.

LAND-RIVER-SKY AND SEA

Places where sea and land meet have demonstrated to be landmarks of civilization. In this sense, there is an ancient character of Lisbon that is a cultural construction and yet common to other ancient civilizations and that character emanates directly from what its topography is in relation to the river and the ocean. Thus, all the lookouts combine land-river-sea. Even a lookout that does not access directly the river-sea does not break down the sense of immense dimension given by the huge extension of water up to the horizon and therefore lookouts are privileged places to a multidimensional experience of space-time. Yet any photograph or image, say such as that created in tiles, may actually embody that experience and thus we are telling about partial views that the artist or the photographer may emphasize.

We may believe that an artist such as Fred Kradolfer may have had a dilemma. On one hand Lisbon provides an overwhelming experience that is the point of departure of the artist himself and by another the artist has under his brush the power of the image. This problem also affects our judgements because we may discuss how far those tile panels are actual art works or, whether they are simply graphic means to achieve an end which is to guide us in an informative way rather in an aesthetic way.

Unlike architecture that has to pursue an end – to live in – art works such as painting and sculpture depend on image alone, they are self-sufficient, they are meant to be experienced insofar as they are an end in themselves, an image per excellence. Yet these panels seem to rely on a certain balance between a self-beauty – and thus they are aesthetically and artistically referable to art works such as paintings – and embody an ability to pursue a particular aim, that is to inform about what different buildings or places are, what their names are and how they relate to each other from that specific place of the lookout. Yet, in this latter sense they are not actual art works, or they have not been conceived as such.



Figure 1: Fred Kradolfer. Coloured panoramic drawing to visual panoramic reading in tiles of the São Pedro de Alcântara Lookout, 1962, The National Tile Museum. © José Vicente

We may reflect on how far Fred Kradolfer would have gone without the experience of Henri de Toulouse-Lautrec and the approach to the advertisement poster as an art work. Thus, we are able to see a deep artistic approach in the way the information panel is actually constructed and how the aesthetic factor appears in the creation of the tile panel itself. And we can reflect further, on how far it could come to someone's mind to create a poster to guide us through an experience that, at the end, would have to be aesthetic despite other points of view that could also influence the creation of the poster itself.

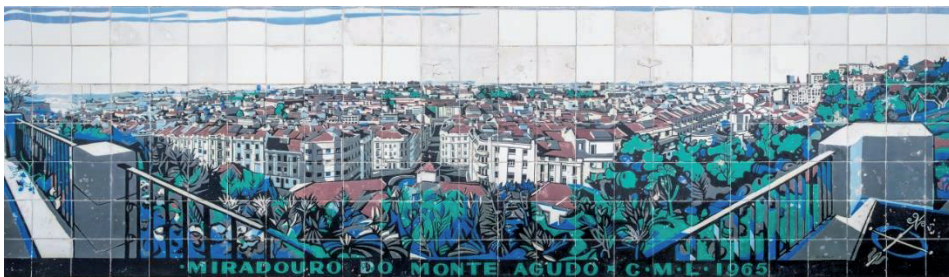


Figure 2: Fred Kradolfer, Visual panoramic reading in tiles of the Monte Agudo Lookout (*Leitores panorâmicos em azulejo do Miradouro do Monte Agudo*) 1965, Fábrica Viuva Lamego. Honorable Mention Award “Best Practice” (Prémio Menção Honrosa “Boas Práticas”), SOS Azulejo 2017, for conservation and restoration intervention © José Vicente

However, the problem of the image is a rather complex one. The images created by Kradolfer have a peculiar perspective, they have a structure of space-time that differs from that we may find in those places. In another words, the actual image we may experience from the lookouts where they stand has been transformed through what has been one of the most critical achievements and metamorphosis in art in general and especially in painting, the representation of space-time.

When we stand and experience one of these lookouts we would not need much of the foreground representation to guide us across the city escape and yet the representation of this first level of perception seemed important to Kradolfer in Monte Agudo (1965) and São Pedro de Alcântara (1962). The hyperbolic perception of space seems to have been a particularly important problem that – we could say – was hardly solved in the first case because he was not able to clarify the relationship between the right and left fences which actually are a single straight fence. Yet, the fact that the second panel is curved seems to have been a good solution that avoids the depiction of the fence.



Figure 3: Fred Kradolfer, Visual panoramic reading in tiles of the São Pedro de Alcântara Lookout (*Leitores panorâmicos em azulejo do Miradouro de São Pedro de Alcântara*) 1962, Fábrica Viuva Lamego. Honorable Mention Award “Best Practice” (Prémio Menção Honrosa “Boas Práticas”), SOS Azulejo 2017, for conservation and restoration intervention © José Vicente

Yet the challenge of the representation of infinity overcomes the problem of the image of hyperbolic space. Historically, the latter came first but at the empirical level, and it depicts the distance that takes us from the Greek Refinements to Giovanni Battista Tiepolo’s pictorial space. However, the most astonishing approaches to the hyperbolic space would be those materialised under Vincent van Gogh’s brush.

Acquaintance with both representations, the Euclidean perspective and the hyperbolic perspective, makes clear that much relies on the foreground rather in the background and small spaces are easy to handle in opposition to large spaces. Thus, the representation of a small room opposes the representation of a huge landscape on the difficulty to stress the hyperbolic space. In this sense, we could say that there is some kind of balance to be explored in the pictorial representation from the Euclidean to the hyperbolic.

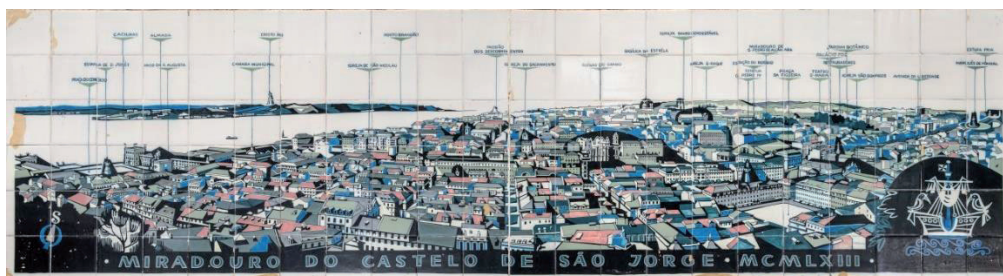


Figure 4: Fred Kradolfer, Visual panoramic reading in tiles of the São Jorge Castle Lookout (*Leitores panorâmicos em azulejo do Miradouro de São Pedro de Alcântara*) 1963, Fábrica Viuva Lamego. Honorable Mention Award “Best Practice” (Prémio Menção Honrosa “Boas Práticas”), SOS Azulejo 2017, for conservation and restoration intervention © José Vicente

Two of the Fred Kradolfer’s glazed tile panels can be opposed to the others under this analytical approach and those are the panels that frame the city space, the river, the ocean and the sky. The panel at the Saint George Castle and the first one at the Senhora do Monte Lookout display a sense of expansive distance, of infinity, alien to the other panels. Lisbon is seen as an oceanic and world city as depicted here but not in the other panels due to the inner reality of the city as seen from those other perspectives. At the time these two panels were conceived there was no bridge over the Tagus and thus the sense of huge dimension towards south and west to the ocean was

greater than it is today. However, the visual impact of an object such as the red iron bridge has a scale of its own, a scale of land, of the river, and of space and time whose magnitude is also vast.

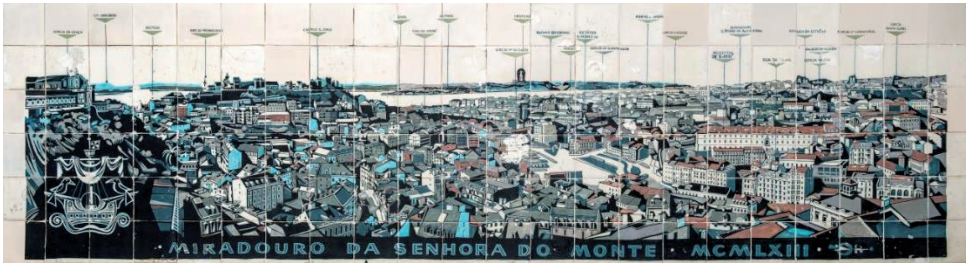


Figure 5: Fred Kradolfer, Visual panoramic reading in tiles of the Senhora do Monte Lookout (*Leitores panorâmicos em azulejo do Miradouro da Senhora do Monte*) 1963, Fábrica Viuva Lamego. Honorable Mention Award “Best Practice” (Prémio Menção Honrosa “Boas Práticas”), SOS Azulejo 2017, for conservation and restoration intervention © José Vicente

The second panel at the Senhora do Monte Lookout also displays an impressive sense of never ending space as the sky flows beyond the background hills. Interestingly, another fact impacts on the perception of the cityscape. These panels are displayed exactly at the lookout that gives a sense of never ending horizon that can be extended as far as infinity. Thus, the presence of the place overtakes what the panels can embody in themselves. Or, we can say that the perception of the place biases the actual content of the panels as art works whose perception would be particularly different if they would be seen elsewhere. Thus, the presence of both a drawing and a panel are a source of reflection on the art work and the aesthetic expression and experience.



Figure 6: Fred Kradolfer, Visual panoramic reading in tiles of the Senhora do Monte Lookout (*Leitores panorâmicos em azulejo do Miradouro da Senhora do Monte*) 1965, Fábrica Viuva Lamego. Honorable Mention Award “Best Practice” (Prémio Menção Honrosa “Boas Práticas”), SOS Azulejo 2017, for conservation and restoration intervention © José Vicente

As one has entered the realm of the art work as such, we could also refer to other pictorial characteristics of the panels and easily find the expressionism to be in their background. However, this fact occurs to the extent that Expressionism combined and recreated afresh former achievements as well as it could provide innovative solutions for pictorial representation. The use of the black colour is, perhaps, of the most importance. By using black, Kradolfer creates a dialogue of light-shade that stresses the whiteness of Lisbon and works as a motif that highlights

important buildings from their background. This is a pure artistic option. That is, the synthesis of colours reduces the overall colours of the city to a few, with each colour performing specific aesthetic roles.

We can also discuss how far there can be an ‘interference’ of the cubist approach to space. We could see the overlapping of buildings as a collage of one façade with another. However, the overlapping of façades is organized in a way that gives a chronology of space and time due to its changeable scale and thus the size of the objects in the foreground along with some partial detail differs from those of the far background. But, we can hardly leave aside the fact that the technique of superimposing different plans reveals particular efficiency of approaching the art of tiles as such.



Figure 7: Fred Kradolfer, Visual panoramic reading in tiles of the São Jorge Castle Lookout 1963. Detail, 2018 © J. Marcelino Santos.

Perhaps another reference needs to be stressed. Kasimir Malevich’s suprematist buildings represent creative ways of reading buildings and cityscapes. The *Architekton in Front of a Skyscraper* (1924) is analytical and portrays architectural construction as not exactly structure alone, but the whole conception of a building and a cityscape as planes and volumes. Where the ground they stem from, including the sky that outlines them and the *black-on-white* or *white-on-black* is rather efficient in taking us to the realm of architecture beyond that of the abstract approach to pictorial space and time.

The problem of the black in Kradolfer does not rely only on being a simple tool to outline buildings. The contour of the object is the notion of form brought in by the Renaissance and we see it in Leonardo da Vinci’s drawings along with his contemporaries. The contour serves to define the form and it is only valuable as far as the form springs from the background and in this sense does not have a life of its own. It serves a principle. But the contour stressed by the Fauvists and the Expressionists expands the sense of the contour of the object to the space where the object exists and thus it tells simultaneously about being *an-itself-by-itself-for-the-object-for-the-space*. The contour embodies the characteristic in being *space-within-a-space* and acquires an extension that it has not had before.

In Kradolfer, the black expands to make buildings noticeable and by doing this the black acquires a pictorial space that goes beyond the contour itself. In fact, the black is not exactly a black line that withers but a spot whose shape is to some extent independent of the building it stresses. Again, this is a pure aesthetic option leading to a particular expression and the fact that such a strategy is repeated insofar as the artist sees it reliable, is created an overall expression combined with other strategies he has worked with. Black has become a full active colour. And yet black is a colour that we hardly assert to Lisbon.

Santa Luzia Lookout

The Santa Luzia Lookout embodies an intense chronology of time. The magnitude of such density is provided by the *land-river-sky* discourse whose origins are to be found in a remote natural landscape which to be transformed by human action. There is a material magnitude former to that of the castle, of the Roman Theatre, of the ancient walls where the lookout stands. And from where the arrangement of buildings reflects different space-time relationships that embody different symbolic meanings. Certainly, a church and a convent differ from the vernacular dwelling and from its subsequent evolution of higher buildings. The long twentieth century wharf line is the strongest artificial metamorphosis that opposes the irregularity of topography and the new cruise terminal building is the expression of the latest landmark through this long chronology of space-time. The wharf topography is that of the flatness of the river but does not share the natural metamorphosis of its colour, reflexion and texture. There is no hilly character in water, nor rapids, nor waterfalls, there is simply a large estuary that flows as inner land flows out to the ocean.



Figure 8: Santa Luzia Lookout. Panoramic photo, 2018 © J. Marcelino Santos.

The lookout comprises two different terraces that articulate an upper and a lower level and we may stress that they are distinct spaces to the extension that actually display two different panoramas that, nonetheless, may be taken as a continuous architectural promenade. Thus, the aesthetic experience that they provide relies on the ability of being as separated as well as connected. Both terraces establish profound relationships with ancient streets and with the iconic Church of Santa Luzia grounded in the early roots of Portugal – formerly Church of São Brás.

In fact, the site articulation makes possible an appreciable range of different aesthetic experiences. It can be, somehow, a sudden change of scales and dimensionalities of space and time or, can be, a slower continuous changeable experience. Perhaps, this place might be one of the most worthwhile to discuss and where many disciplines may meet from that of the historian and the art historian, to the architect, or urbanist, to the philosopher and phenomenologist. Thus, in a short reflection only a few aspects can actually be approached.



Figure 9: Santa Luzia Lookout. Upper and lower terraces, 2018 © J. Marcelino Santos.

The way in which the tiles are distributed through the space has a remarkable importance on the way the space is perceived. In fact, it is most likely that the first tiles one sees are the decorative tiles that furnish the small walls. In terms of the intrinsic nature of objects, the tiles do not differ much from those generally found in the variety of buildings that we see across the city. The strength of the single motif produced by the qualities of the two-dimensional space that can be repeated through a plane are particularly significant at this site.

Unlike the way one experiences the tile façades of buildings, here one is able to sit and touch the tiles. One sees colours, textures and feels temperatures. Besides, as one moves in, one is going to see closer and closer those motifs and thus they give a higher contribution the sense of space-time across the space. The experience of details at close proximity is different than when experienced from a distance. And the close experience of the detail reaches an acme when we are so close to the wall that we experience the large scale of the site. Thus, there have been constructed *a priori* conditions to comprehensive multidimensional experiences of space-time.

The large panoramic panels have a different role in relation to the structure of space. They display views from past times and create a sense of interiority to the space. The individual who experiences the space does not sit right next to them, nor would touch them. The 'View of Terreiro do Paço at the Early 18th Century' requires some distance to be perceived and yet it also comprises the small figure whose detail may need a closer look. There is a sense of experience that combines the way we walk through the garden and the experience of the panoramic scene displayed on the wall of the church of Santa Luzia. Also, the tiles have, somehow, the power of transforming the outer façade of the temple into the inner façade of the garden. There is a peculiar *spatio-temporal* construction unique to the lookout and the tiles have high relevance in this interaction. On the opposite side, the pergola over the huge ancient wall closes and opens the space by creating a space within a space. And, in fact, this is what the lookout is made of, of spaces within spaces, of distances, of boundaries and material events through the space that create different rhythms all across possible path ways and the individual is free to choose from them.



Figure 10: View from the Santa Luzia Lookout, 2018 © J. Marcelino Santos.



Figure 11: António Quaresma, View of Terreiro do Paço at the Early 18th Century, (*Vista do Terreiro do Paço nos começos do século XVIII*) c.1929, Fábrica Viúva Lamego. Prize Winner for on restoration and conservation, (“*Intervenção de Conservação e Restauro*”) SOS Azulejo 2017 © José Vicente

This panorama of Lisbon crosses the chronology of time to the present. In some sense, as one looks at the river experiences of the present and by looking inner land we experience memory. However, this memory is only an introduction to the magnitude of a historical time that the land itself has witnessed. The magnitude of time provided by the land-river-sky means a discourse whose origins are to be found in a natural landscape to be transformed one day by the human will.



Figure 12: Santa Luzia Lookout, 2018 © J. Marcelino Santos.

However, the magnitude of space time is given through a confined space in which the pergola and the wall-panel element are as important as the *terra firma* or the sky. Thus, there is also a smaller scale inner environment of the garden given by a *now-for-us* sense that grounds our aesthetic experience versus *past-present-future*, to the city that has never yet been.



Figure 13: Santa Luzia Lookout. Lower terrace, 2018 © J. Marcelino Santos.



Figure 14: Jaime Martins Barata (tiles) after a painting by José Vitória Pereira. Panorama of Lisbon, c.1939. Manufactured by Viúva Lamego. Prize Winner. Best Practice (“Boas Práticas”) SOS Azulejo 2015 for restoration and conservation. © José Vicente

The lower terrace which was built in the 1940’s which depicts the Panorama of Lisbon produced for the 1940 Exposition of the Portuguese World is, somehow, between the future and the past. The blue option means there is no attempt to recreate the art of glazed tile despite the fact that Portuguese tiles were as blue as polychromatic. Nonetheless, by being blue the tiles define potential readings of the history of Portuguese tiles which may be a partial view, an outlook of a regime assumed by the artists and which is certainly biased.

One may shortly assert the panorama of Lisbon to the spatial organization of the exposition. The rural Portugal is depicted by the two traditional boats and the warships symbolise progress. In some sense, all elements are as static as the vision of a proud Portugal, past, present and future. Paradoxically, it seems that the aesthetic of the tile panel reduces the vision of that history in the same way that the panel has reduced the history of glazed tiles to a monochromatic past, as it does not have the courage to recreate a cultural tradition afresh.

Last but not least, the interpretations of the panels by Fred Kradolfer may be considered to be biased by the necessity to stress aesthetic qualities but those panels may comprise stronger elements to a chronology of the development of the art of glazed tiles than the panels of the Santa Luzia Lookout. Yet, there is an ‘internal’ organization of the site that overwhelms the panels as individual elements and the city overcomes all chronologies of the history of tiles.

THE PUBLIC RULE IN THE RESTORATION – A CULTURAL NEED

Lisbon lookouts are fundamental public spaces and therefore the role of the City of Lisbon is strategic in pursuing suitable uses as well as adequate strategies of rehabilitation of these places. And the presence of tiled panels maximizes the importance of requalification of these places where we experience both tiles and the city in a close and touchable way. We could stress, an intimate way that makes the aesthetic experience a vivid act.

The years 2015 through 2017, the responsibility of this task was held by the Unity of Intervention of the Historical Centre (UITCH), which is a department of the Unity to Territorial Coordination (UCT) – Unidade de Intervenção Territorial Centro Histórico (UITCH) da Unidade de Coordenação Territorial (UCT). The prizes ‘SOS Azulejo 2015’ and ‘SOS Azulejo 2015’ were welcome and meant that there is already a wide concern with the Portuguese tile heritage as well as with the necessity of its preservation.

The number of people, locals or tourists, that experience these lookouts is far higher than the number of people that enters museums, churches, or convents and thus, these places also work as vestibules to other comprehensive explorations of this art. There is a pedagogic context that goes beyond the given experience of these places. Consequently, the aim of the requalification as performed by the City of Lisbon stressed an overall rehabilitation of the lookouts.

CONCLUSION

Lisbon is a type of settlement that has roots in ancient strategies of changing the topography of the site. The historical walls of Lisbon are characteristic to that metamorphosis as well as all terraces that define the outlooks. We may trace back the origin of these sites to functional need of man but they seem to have acquired a single use which is fundamentally aesthetic to be in the place and to experience the cityscape alone. Thus, there is a new symbolic use nonetheless constructed in the ancient topography as well as in its metamorphosis whose materiality is often seen or felt. The presence of the ancient walls of Lisbon and of the castle is particularly important to this acquaintance with place.

As far as these sites are cultural constructions, the presence of tiles is of highly relevant importance. The tiles tell about a chronology of time that brings about an evolution of this art. Although it is not a comprehensive chronology its importance seems relevant not only by the fact that they return to the ability of creating a sense of interiority by the way how the space interacts reciprocally with them, but also because the panoramic panels may open a discussion to the evolution of Modern Art.

The importance of restoration held by the City of Lisbon and its public recognition is certainly a high contribution to the discussion of the perfect strategies of restoring tile panels as well to reflect on the new horizons that this art may embody in order to be recreated afresh. Last but not least, one should emphasize the rule of teamwork leading to the restoration of lookouts.

Acknowledgements

Tile conservation project by Municipal Council of Lisbon: Fátima Alcobia; Fernando Lopes; Helena Lopes; Pedro Miranda and Rui Matos.

Yearly, the Historical Centre Territorial Intervention Unity (UITCH – Unidade de Intervenção Territorial Centro Histórico) identifies priorities to restore artistic historical heritage artefacts in public spaces in Lisbon historical centre. A historian and archaeologist team coordinate scientific research with art restorers, architects and engineers and defines projects and intervention strategies according to recognised scientific methodologies. The works are then executed and supervised by these experts. The team also coordinates the intervention with the Directorate-

General for Cultural Heritage (DGPC – Direção-Geral do Património Cultural) for buildings or artefacts that are classified. Yet, a general coordination with local community and all companies that operate infrastructures in public space is always required. UITCH is a department of the Unity for Territorial Coordination (UCT – Unidade de Coordenação Territorial). The head of UITCH is Isabel Maciel and the head of UCT is Helena Caria.

Bibliographic references

- AA, vv – *História da Arte Portuguesa*. 3 Vols. Circulo de Leitores, Lisboa, 1995
- AA, vv – *Lisboa Quinhentista. A Imagem e a Vida da Cidade*. C.M.L. e Museu da Cidade. Lisboa, 1983.
- ALMEIDA, Fialho de – *Lisboa Monumental*. Câmara Municipal de Lisboa, Lisboa, 1957
- ARAÚJO, Norberto de – *Inventário de Lisboa*. Lisboa, 1947
- ARAÚJO, Norberto de – *Peregrinações em Lisboa*. Tomo VIII – X. Lisboa, 1939.
- ARGAN, Giulio Carlo – *Arte Moderna. Do Iluminismo aos Movimentos Contemporâneos*. Companhia das Letras. São Paulo, 1992.
- BÁRTOLO, José; SILVA, Jorge – *Fred Kradolfer. Design de Comunicação e Expositivo*. Imprensa-Nacional Casa da Moeda, Lisboa, 2012.
- CASTILHO, Júlio de - *Lisboa Antiga-Bairros Orientais*. 2ª ed., Vol. VII. Lisboa, 1927
- FRANÇA, J. Augusto – “Imagens de Lisboa através dos séculos”, in *Rassegna*, Ano XVI, nº 59. Bologna, 1994.
- DUFRENNE, Mikel – *The Phenomenology of Aesthetic Experience*. Northwestern University Press. Evanston, 1973.
- GÓIS, Damião de – *Olisipo Descriptio*. (edição original 1554). Livros Horizonte, Lisboa 1988.
- GOMBRICH, E. H.: *The Story of Art*. Phaidon. London, 2007.
- Guia da Exposição do Mundo Português (edição 1940). Neogravura, Lisboa, 2014
- HEELAN, Patrick A. – *Space-Perception and The Philosophy of Science*. University of California Press, Berkeley. Los Angeles, 1983.
- HOLANDA, Francisco d' – *Da Fábrica que Falece à Cidade de Lisboa* (edição original de 1571). Livros Horizonte. Lisboa, 1984.
- MECO, José – *Azulejos com monografia de Lisboa*. Actas do Simpósio Lisboa em Discussão. Amigos Lisboa. Lisboa, 1994.
- MOITA, Irisalva (Dir. de) – *Livro de Lisboa*. Livros Horizonte. Lisboa, 1995.
- SOROMENHO, M. – *O Paço da Ribeira à medida da Corte: de Filipe I a D. Pedro II. Do Terreiro do Paço à Praça do Comércio. História de um espaço urbano*. Imprensa Nacional Casa da Moeda. Lisboa, 2012.
- Revista dos Centenários. Nºs 19 – 31, Comissão Nacional dos Centenários. Lisboa, 1940.
- Revista Municipal (1983). Ano XLIV, nºs 5 e 6. Câmara Municipal de Lisboa. Lisboa, 1983.
- PANOFSKY, Erwin: *Perspective as Symbolic Form*. Zone Books, New York, 1997.
- RICCI, Giovanni – *Cuidad Amurallada e Ilusion Olográfica(...)*. La Città e le Mura. Madrid, 1991.
- RODRIGUES, Maria João Madeira – *Cidade Oceânica e Mundial. Fundamentos da Teoria do Urbanismo Português*. GEHA Ano 2. Revista de História, Estética e Fenomenologia da Arquitectura e do Urbanismo Universidade Técnica de Lisboa, Faculdade de Arquitectura. Lisboa. 1999.

ROSSA, Walter – *Lisbon's waterfront image as allegory of baroque urban aesthetics*. Architecture in Europe and the Americas. Ed. Henry A. Millon, National Gallery of Art. Washington, 2005.

ROSSA, Walter – *Lisboa e o Rio, paradigmas de cidades atlânticas*. Catálogo da exposição. Câmara Municipal de Lisboa, Lisboa, 2008.

SILVA, Augusto Vieira da - *Dispersos*, Volume II. Câmara Municipal de Lisboa, Lisboa, 1960.

TATARKIEWICZ, Wladyslaw – *History of Aesthetics; Vol.III, Modern Aesthetics*, Mouton/The Hague, Paris and Pwn-Polish Scientific Publishers, Warsawa. Paris, Warsawa, 1974.

TORMEY, Alan; TORMEY, Judith Farr – *Renaissance Intarsia: The Art of Geometry*. Scientific American, Vol. 247, No. 1, July 1982, Scientific American Inc. New York, 1982.

TÚLIO, António da Silva – "Lisboa Velha e Lisboa Nova", *Archivo Pittoresco*. Vol. III. Lisboa, 1860.

VASCONCELOS, Luis Mendes de - *Do sítio de Lisboa*. Diálogos (edição original de 1608). Livros Horizonte. Lisboa, 1990.

VIDAL, José Pina – *Miradouros de Lisboa*. Revista Municipal. Ano XXII, nºs 88. Câmara Municipal de Lisboa. Lisboa, 1961.

The use of modern azulejos and panels in Portuguese shop fronts

Catarina F. M. Geraldès

Departamento de Conservação e Restauro, Faculdade de Ciências e Tecnologia, Universidade NOVA de Lisboa, Caparica, Portugal; Laboratório Nacional de Engenharia Civil (LNEC), Lisboa, Portugal; cgeraldès@lnec.pt

João Manuel Mimoso

Laboratório Nacional de Engenharia Civil (LNEC), Lisboa, Portugal, jmimoso@lnec.pt

Alexandre N. Pais

Museu Nacional do Azulejo, Lisboa, Portugal, apais@mnazulejo.dgpc.pt

SUMMARY: There are several books about the modern tiles (azulejos) in Portugal, often centring in well known cases by renowned artists or more "spectacular" applications.

Spread throughout Portugal (and not only in Lisbon) there is also an important heritage of modern tiled shopfronts that are often neglected and therefore face silent destruction as the shops are passed on to new owners and different branches of business.

This communication presents a wealth of modern shopfronts, survivors from a lost era and now in dire danger of permanent loss.

SUMÁRIO: Existem vários livros sobre os azulejos modernos em Portugal, muitas vezes centrados em casos bem conhecidos por artistas de renome ou aplicações consideradas mais "espetaculares".

Espalhada por Portugal (e não apenas em Lisboa), há também um importante património de lojas com aplicações exteriores de painéis cerâmicos ou de azulejos com padrões modernos que são frequentemente esquecidos e, portanto, enfrentam uma silenciosa destruição à medida que as lojas são passadas para novos proprietários e diferentes ramos de negócio.

Esta comunicação apresenta um conjunto de lojas com aplicações cerâmicas modernas nas fachadas, sobreviventes de uma era perdida e agora em risco de perda.

KEY-WORDS: Modern azulejos / shop fronts / modern decoration / Portuguese azulejos

INTRODUCTION

There are several books and works about modern tiles (azulejos) in Portugal [1-5], often centring in well known cases by renowned artists or more "spectacular" applications.

The close collaboration between Portuguese modern architects and artists resulted in appreciable benefits to the tiles of the modern period and certainly contributed to the resurgence of an artistic industry that was in decline before the 2nd World War.

As discussed by the same authors [6] a particular case of azulejo integration includes those cases in which the lining at the ground floor is either the only one or significantly different from the rest of the building, often connected with a commercial purpose. Aesthetically speaking,

these linings are important also because they are easily perceived, even in narrow streets, where the upper levels will go unnoticed. They are often, as well, creations that project or reflect the intention of an artist or a designer to transmit appreciative emotion.

The case of shopfronts is singular in the fact that their design reflects the style of the time when the shop opened or was refurbished and not that of the building itself which may be much older. In Portugal, there is an important heritage of modern tiled shopfronts that are often forgotten and therefore face-silent loss as the shops are passed on to new owners and different branches of business. This communication presents a wealth of modern shopfronts, survivors from a lost era and now in danger of permanent loss.

PORTUGUESE SHOP FRONTS

In the following sections, we present examples of modern shop fronts with integrated azulejo panels, either artist-designed or simply resulting from the application of pattern tiles. All cases are considered from the point of view of a street walker and some types of azulejos were identified: artistic azulejo panels or ceramic plaques, signed or unsigned; repetitive patterns; small *Tijomel* tiles; and flat or textured monochromatic azulejos. These were found in different localities: Lisboa, Porto, Torres Vedras, Torres Novas, Viseu, Beja and others.

Figure 1 shows an example in Lisbon, where the type used was designed by the well-known artist Maria Keil (1914-2012) [7] who personally identified tiles of the same pattern in the collections of the *Museu Nacional do Azulejo* as her own. However, as far as we know, this particular application was never mentioned in the literature.



Figure 1: *Rua da Portas de Santo Antão N° 77*, Lisbon

Figure 2 shows another example in Lisbon, this time already referred in the bibliography [6] with an artistic panel signed by Lucien Donnat (1920-2013). This is the front of a shop named *Pelaria Pampas* but once it was a tobacco shop (*Havaneza dos Retroseiros*) presumed to have inspired Fernando Pessoa's poem of the same name [8]. Both the uniqueness of the artistic panel and the symbolism of the location are *per se* reasons for conservation.



Figure 2: Shop *Pelaria Pampas* in the *Baixa* area of Lisbon, located at the intersection of *Rua da Conceição N° 65* with *Rua da Prata*

Figure 3 illustrates a case in Torres Vedras of an artistic panel decorating a shop front whose design is only whole with the panel. The panel is signed “Daciano” and dated “1955”. The whole shop must have been designed by Daciano da Costa (1930-2005) Portuguese artist and remarkable designer. One of his works (from 1972) is precisely the congress centre of LNEC where GlazeArt2018 takes/took place, including all the decoration, furniture and lightings. This shop, which we identified, is one of his earliest works and the signed panel one of the very few examples of his art on azulejos. The shop closed and *Museu Nacional do Azulejo* contacted the Municipality to offer information on the heritage value of the shop front.



Figure 3: *Casa Primavera* shop front. *Rua Miguel Bombarda N° 4*, *Torres Vedras*

Another sort of glazed architectural finishing is made with monochromatic azulejos, sometimes shaped or textured or painted in hues of the same colour (figure 4). Since the decoration is not graphic, the aesthetic value is often lower, although it must be remarked that azulejos in shades of the same colour allow the creation of interest on façade areas that otherwise might be simple and uninteresting. The example shown is another case of a closed shop and consequently calling to mind its uncertain fate.



Figure 4: *Rua Ricardo Espírito Santo N° 8A*, Lisbon

The following images demonstrate several modern shop fronts in different towns where the azulejos are integrated. The panels found often present artistic compositions and the beauty of their integration may stem solely from the azulejos, mostly from the integration, or both when the azulejos are harmonized with the rest of the shops or buildings.

Figure 5 is an example of a simple coffee shop made remarkable by a lovely front with an artistic azulejos panel decorating the exterior seating area destined for clients.



Figure 5. Coffee shop in *Avenida Miguel Bombarda N° 133*, Lisbon

Figures 6 and 7 are interesting examples of azulejo panels integrated in shop fronts. In the first, the composition is in blue colours with ocean inspired motifs, such as geometric fish and was once the front of a restaurant specialized in seafood. In the second, the composition is made by azulejos in "warm" colours and with Porto city represented. However, in this case, the design is only perceived from a distance.



Figure 6: Azulejos panel made of ceramic plaques in *Rua da Madalena N° 253*, Lisbon

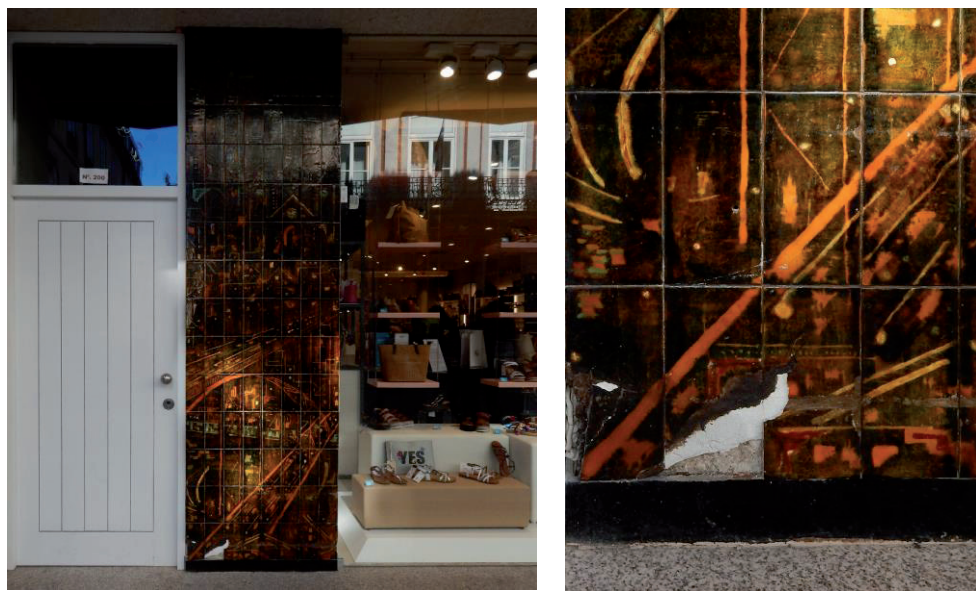


Figure 7: Seaside shop in *Rua de Santa Catarina, Porto*

As discussed by the same authors [9] it is relevant to mention a type of glazed ceramic coating that came recently to their attention, Tijomel azulejos, whose dimensions are different (ca. 18 x 38 mm) from the common Portuguese azulejo (ca. 140 x 140 mm) and which were widely used in Portuguese modern architecture.

The images below show the application of linings with those small tiles in some towns visited, such as Lisbon, Porto and Beja and the type of application, at street level on shops front. These are just examples that were considered worth mentioning but many others, we believe, should be cared for and safeguarded.



Figure 8: Shop in the *Baixa* of Lisbon. *Rua da Prata* N° 269-271



Figure 9: *Rua Gomes Freire* N° 14, Lisbon



Figure 10: Coffee shop in Rua da Boa Hora N° 2, Porto



Figure 11: Regional shop in Rua de Mértola N° 65A, Beja

A slightly different case often neglected is the example in the figures below, made by using glazed ceramic tiles. The first (figure 12) is an interesting example in Porto, it is a modern bar inspired by the Polynesian tradition. The execution of the shop front albeit recent uses modern azulejos and bears witness to a remarkable technique: the panel composition is made with sets of differently textured azulejos, including designs by Ferreira da Silva for Secla, with fused glass areas and tiles by *Fábrica Constância* of Lisbon (both ca. 1960s), and the striking contrast between them creates an impact on the viewer with an unmistakable *tiki* flavour. The second case (figure 13) is also a panel in Porto, where ceramic plaques used have the same design and colours, white and orange or red. However, the position of application is different, as if it was a "game of position" where the impact on viewers is obtained through texture and position. The third case (figure 14) is that of a shop in the *Baixa* of Lisbon, where the panel is composed by a set of ceramic plaques of different sizes themed on shoes, plants and birds for a shoe shop (an

amusing allegory because in Portuguese the sole is called “planta do pé” - plant of the foot, while the tip of the shoe is called “bico do sapato” – beak of the shoe).

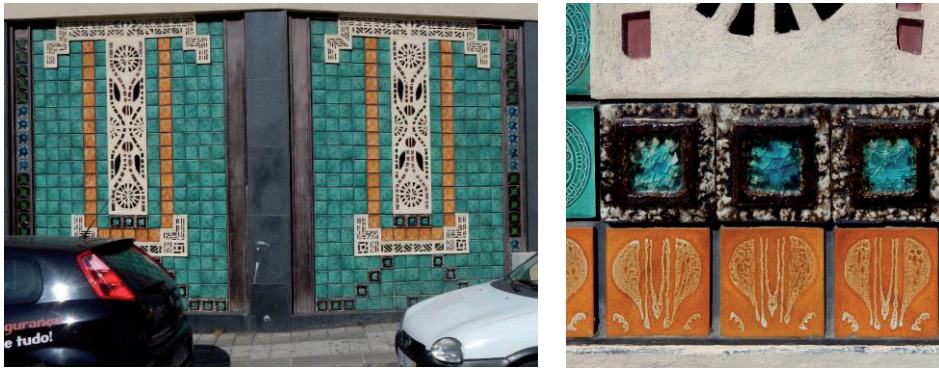


Figure 12: Polynesian Bar in *Rua das Águas Férreas N° 9, Porto*



Figure 13: *Rua de Sá da Bandeira N° 331, Porto*



Figure 14: Shoes shop in *Praça do Rossio*, downtown area of Lisbon

Figure 15 presents an interesting shop located in a little-visited town, Torres Novas, and it is a rare example of single figure tiles from the 1940-50s that due to its smaller dimension (one fourth of the normal size of an azulejo) are called in Portuguese lambrilhas. Another example is shown in figure 16, where glazed ceramics with a protruding face and in shades of the same colour, create texture, variety and interest to areas that would otherwise be rather plain.



Figure 15: Travel agency in the centre of the town of Torres Novas



Figure 16: Rua de João Pedro Ribeiro N° 595, Porto

CONCLUSION

Integrated azulejos, new or old, must be valued as a national mark but they go often unnoticed possibly because “Portuguese eyes” are so very used to them. Not only in Lisbon but spread throughout Portugal there is an important heritage of modern tiled shopfronts that are often neglected.

This communication presents several examples of modern shopfronts with integrated azulejos, survivors from a lost era.

Although tiled façades are now protected shop fronts are often forgotten because they only pertain to a small part of the façade. But that part is indeed the most readily visible by passers-by. And they are at risk, not only because of the urban expansion but mostly because new shop owners refurbish the fronts often neglecting the tiles that went into the design of the previous avatars of that shop. If their preservation is not specifically assured, modern shopfronts will soon be a dimming memory of the past.

Acknowledgments

The authors acknowledge the Portuguese Science Foundation (FCT) for the funding of PhD grant PD/BD/114408/2016 (Catarina Geraldes) and Project FCT-AzuRe - Estudos no Azulejo Português para Candidatura a Património da Humanidade (PTDC/EPH-PAT/5096/2014) for supporting this research.

Bibliographic references

- [1] HENRIQUES, Paulo et al. - *O Azulejo em Portugal no século XX*. No. of edition ISBN 972.787.009.0, Editor Inapa, Lisboa, 2000.
- [2] BURLAMAQUI, Suraya - *Cerâmica Mural Portuguesa Contemporânea, Azulejos, Placas e relevos*. ISBN 972-564-270-8, Editor Quetzal, Lisboa, 1996.
- [3] SAPORITI, Teresa - *Azulejos de Lisboa do século XX*. No. of edition 437, Editor Porto: Afrontamento, Lisboa, 1992, ISBN 972-36-0199-0.
- [4] AMARAL, Ricardo - *Arquitectura & Cerâmica: o espaço da tradição mural na contemporaneidade*. Master dissertation. Porto University, ID: 2015.
- [5] ALMEIDA, Ana - *Da cidade ao Museu: uma proposta de itinerário pela azulejaria de autor na Lisboa da segunda metade do século XX*, Master dissertation, Lisbon University, 2009.
- [6] GERALDES, Catarina; PAIS, Alexandre; MIMOSO, João Manuel - *Aesthetics utility and values: a systematization of glazed ceramics in the façades of modernist architecture*, In: M. Menezes, D. R. Costa, J. D. Rodrigues (eds.) Congress Book Proceedings for the IPERION CH international conference - Intangibility Matters, Lisbon, 29-30 May 2017, pp 23-31.
- [7] [online] https://pt.wikipedia.org/wiki/Maria_Keil [Accessed 10 July 2018]
- [8] GOMES, Maria Amélia - *Fernando Pessoa, amigo de Lisboa* in revista *Olisipo* Nº 150-152, pp. 160 [online].
- [9] GERALDES, Catarina; PAIS, Alexandre; MIMOSO, João Manuel - *The use of “Tijomel” tiles in Portuguese modern architecture*, In: Congress Book Proceedings for the International Conference Glazed Ceramics in Cultural Heritage, Lisbon, 29-30 October 2018.

No Secret Beyond the Door: the Rampa store and its doorframe, a collaboration between Querubim Lapa and Conceição Silva, 1956

Rita Gomes Ferrão

IHA-UNL – Instituto de História da Arte – Universidade Nova de Lisboa, Lisbon, Portugal,
ceramicmodernistaemp Portugal@gmail.com

SUMMARY: In his film “Secret Beyond the Door” (1947), German director Fritz Lang introduced the symbolic concept of “felicitous room” developed by a character who is an architect exploring a thesis according to which the way a place is designed determines what happens in it. Appropriating the concept of “felicitous room”, this paper intends to problematize the earlier collective work of artist Querubim Lapa and architect Francisco da Conceição Silva, especially addressing the case of Rampa, a store in the centre of Lisbon, and the “felicitous” story of its doorframe, designed in 1956.

KEY-WORDS: Modern ceramic, Querubim Lapa, Felicitous room, Modernism, Conceição Silva

A “FELICITOUS ROOM”

In his American classic film noir “Secret Beyond the Door” (1947) (Figure 1), German director Fritz Lang (1890-1976) introduced the symbolic concept of “felicitous room” developed by a character who is an architect that publishes a magazine on Modern architecture, where he explores the thesis according to which the way a place is designed determines what happens in it, such as a certain church building where miracles usually happen.

Appropriating the concept of “felicitous room”, this paper intends to problematize the earlier collective work of Querubim Lapa (1925-2016) and Francisco da Conceição Silva (1922-1982), especially addressing the case of Rampa, a three floor store in the centre of Lisbon, designed in 1956, to sell fashion, art and design items.



Figure: Film stills from “Secret Beyond the Door”, Fritz Lang, 1947

When the artist meets the architect

In the 1950s and 1960s of the 20th century, architecture was by and large perceived as a means of transforming the world and social organizations, a legacy of the period between the wars, and which was restored after the end of World War II. The need for reconstruction of European cities and the implementation of the Marshall Plan would create numerous opportunities for the restoration and construction of new buildings. In addition, it strengthened both the economy and the private sector. There was also the growth of investment in the development of the colonized countries, where the latest urban and architectural proposals gave rise to innovative equipment. That was the time of the re-emergence of the integration of arts into architecture, endowing the functionalism of new requirements of comfort with the new consumer needs.

Karl Badberger (1888-19?), the German architect responsible for the reconstruction plans of West Germany, leading the Bundesbaudirektion (Federal Building Authority) in Bonn, after World War II, stated in “Planen und Bauen im Neuen Deutschland”, 1960: “the starting point to know if the work of art in the building only features decorative value or tectonic function is by checking whether the work of art or architecture can exist without each other. (...) Moreover, it is not enough for the artist to achieve this capacity of integration in architecture. The architect also needs a comprehensive understanding of the possibilities of the sister arts. (...) The need to employ the embellishing hand of the artist has become, as the war gets more distant in time, to be imperative once again. Architecture has conjured forms through materials and their use that have deserved general approval, in such way that the arts, to whom they served, also received guidelines and spirit. Besides that, a certain ease for each art has become predictable. Whilst there was no money for bread, neither there was money for butter.” (1)

Finally, when money for butter did turn up, it proved necessary to implement new work methodologies by defining the place and role assigned to various arts from the beginning of each project. Architects and artists worked together sharing a common goal and collaborated on solutions that served common interests. As a general rule, architecture offices were responsible for the invitation and integration of artists within work teams. In that context, Querubim Lapa was to begin an extensive ceramic work, by distinguishing himself as one of the artists who best knew how to understand the principles of integration of arts in architecture.

In Portugal, after the end of World War II, the Estado Novo autocracy reorganized itself. There arose reformist currents inside the regime, despite the outpouring of support for Oliveira Salazar (1889-1970) that took place in May 1945 at Terreiro do Paço, Lisbon. The national artistic production was split in two, between a strongly politicized Neo-realism and an iconoclast Surrealism, both of them in opposition to the regime. In July 1946, at the initiative by MUD (Movimento de Unidade Democrática - The Democratic Unity Movement), the first Exposição Geral de Artes Plásticas (General Fine Arts Exhibition) took place and shook the press that supported the political governmental forces. The new exhibition formula with no jury and no prize, would be held annually in the halls of the National Society of Fine Arts, until 1956. Conceição Silva was involved in the organization of the General Fine Arts Exhibitions since the beginning, when he was still an architecture student. There he showed his work and helped to promote the work of other young fellow architects and artists. By 1954, when Conceição Silva finally was appointed for the National Society of Fine Arts board of direction, the General Fine Arts Exhibition had already achieved a prominent status in the opposition to the regime.

Querubim Lapa, with a background in sculpture and painting, began his career in the mid-1940s, inside the Neo-Realist movement. The artist made the first contact with Neo-Realist work when he was still a student. The opposition to the Salazar regime was evidenced especially in the choice of themes and in the refusal of the so-called official art, which was supported by SNI (2) and directly associated with the first generation of the Portuguese Modernism (3). In 1945, along with Pedro Oom (1926-1974) and Julio Galvez (1924-2004), Querubim exhibited sketches and

watercolours for the first time at the Institute of Italian Culture. Oom took on denouncing social inequalities through his sketches, what contributed to rekindle Querubim's awareness, who in the following year would develop the series of sketches called "Mendigos" (Beggars) and where he assumed unequivocally the Neo-Realistic expression. At the same time, in order to acquire economic independence, Querubim accepted the invitation to work with the sculptor Joaquim Martins Correia (1910-1999), who had appealed for an assistant to help in strenuous tasks, such as assemblage and filling of moulds. Martins Correia's workshop would truly become a school where Querubim learned about sculpture and received a cultural education. It was also there that, at an early age, he would have the privilege of meeting outstanding personalities in different artistic areas, such as the painters Louis Dourdil (1914-1989) and Hansi Staël (1913-1961), the writers Natália Correia (1923-1993) and Ruben A. (1920-1975), among many others who came around the workshop.

In 1947, Querubim Lapa joined the Sculpture course at the Lisbon School of Fine Arts (he would also complete the Painting course in 1978) and shared then a studio on Garrett Street with the painters António Ayres (1929-1951) and Daciano Costa (1930-2005) (4). In that same year, he took part in the twelfth Exhibition of Modern Art organized by SNI, an institution with which Querubim would not come to cooperate again, thereby strengthening his antagonism towards the regime's policies. Instead, he participated in the General Fine Arts Exhibition for the first time during its Fifth Edition, in 1950, the year he painted "Espelho Partido" (The Broken Mirror), a painting that would be later acquired by the National Museum of Contemporary Art. Querubim was to keep on participating regularly in future editions of the event. In 1953, when he completed the Fine Arts course, his work seemed pretty much prepared for a new direction. The following was written in the "Arquitectura" magazine about the works exhibited at the 7th General Fine Arts Exhibition: "(...) Querubim Lapa's painting is exquisitely decorative; it pays attention down to the smallest detail, served by a resourceful technique that is both cerebral and static. In the context of concerns, it leads to architecture and to the rediscovery of the wall cloth – the goal of much of the contemporary painting." (5). The text foresaw future transformations in the work of the artist by rediscovering the wall cloth and the approach to the architectural scale, a path he metamorphosed in ceramics shortly after. Querubim began his ceramic work through the contact with architects that participated in the General Fine Arts Exhibition. Solid friendships ensued from that coexistence and allowed him to create a network of contacts that broadened the development of an unprecedented collaborative work in Portuguese architecture. Starting with Raul Chorão Ramalho (1914-2002) and Artur Pires Martins (1914-2000), it was with Conceição Silva he was able to achieve more profound and rewarding results, creating such a unity that "the work of art or architecture can't exist without each other".

Querubim started his collaboration with the architect in 1955 by designing the tile patterns for the facade of Armazéns do Minho (Minho's department store) (6) (Figure 2), in Moçâmedes (present-day Namibe), Angola. The design of the composition was based on a set of curvilinear forms, introducing dynamics in an orthogonal facade layout.



Figure 2: Armazéns do Minho (Minho's department store), Angola, 1955. Photograph CEQL.

The following year, Querubim strengthened the cooperation with Conceição Silva by conceiving the Rampa store's doorframe, his first three-dimensional ceramics project for architecture and a structural element to the facade.

RAMPA and its doorframe

The modern spirit found a breathing space in Europe, USA and Japan, after World War II. The beginning of the second half of the century proved to be a golden time for the ceramic industry and for exclusive pieces bolstered by the opening and growth of international markets. By 1946, Pablo Picasso (1881-1973) had already carried out the first experiments at the Madoura ceramic workshop, in the South of France, and legitimized ceramics as an ultimate expression. In Portugal, artists José Ernesto de Sousa (1921-1988) and António Quadros (1933-1994) played a key role in the dissemination of the folk arts by stating the grounds for their influences on the fine arts. Thanks to them, the potter Rosa Ramalho (1888-1977) acquired national visibility, as the expression of the figuration from the Barcelos region (Figure 3).



Figure 3: Rosa Ramalho's picture and Barcelos pottery near Querubim Lapa's pieces in his workshop at Viúva Lamego factory, c. 1962. Photograph CEQL.

Jorge Barradas (1894-1971), a pioneer in exclusive ceramic pieces, was the first one to capitalize on that opportunity and redesigned his whole artistic production from the first half of the 1940s, leading the way for younger artists. When Chorão Ramalho introduced Querubim Lapa to the Viúva Lamego factory it already housed private workshops of two ceramic artists, Barradas and Manuel Cargaleiro (b. 1927). The factory was founded in 1849 and enjoyed a long tradition in Portuguese tile making, including large commissions for architecture. Querubim was to execute several small jobs in Viúva Lamego's painting studios and Eduardo Leite da Silva, one of the owners and manager of the factory, recognized his qualities and work aptitude and invited him to occupy a private studio, thus adapting an old warehouse space for that purpose, where Querubim would end up working many years, and where he studied and experimented in ceramics, painting on tiles and creating large-scale works. Leite da Silva had been a respected tile painter in his youth and was one who contributed the most to the renewal of ceramics in Portugal, mainly by supporting, welcoming and granting the ceramists a place to work.

The reasons Barradas, who was a master designer and illustrator, took an interest in pottery would be the same that led many other artists to do so later. The art market in Portugal was a precarious one and was dominated by the Central Government's commissions through SNI, or restricted to the requirements imposed by the domestic interiors of an uninformed high bourgeoisie, also unable to understand modern tendencies. Thus, many artists would devote themselves to the applied and decorative arts by drawing objects, furniture, tapestries and ceramic panels. The exclusive ceramics came in some way to serve the demands of the market, which was in need of decorative, colourful and modern objects that were accessible to the middle and upper-middle classes. However, that activity also catered to the survival of artists, who sold small pottery items that were more easily acquired than works of larger scale and modern content, like paintings or sculptures.

That made way to the emergence of a group of new ceramists, who would end up exhibiting works, especially in initiatives organized by SNI, or in small galleries such as Diário de Notícias or Pórtico. In line with a consolidated practice since the 1920s, artists exhibited their work at non-specialized sites, thus the near absence of galleries. During the 1930s, the UP Gallery, established by António Pedro (1909-1966) and Tom – Thomaz de Mello (1906-1990) became the first commercial gallery geared towards works of art and exclusive designs. Several shops of interior decoration and furniture stores were also to join this purpose, by extending it to industrial design in the mid-1960s.

In that context, in 1956 the Rampa store opened as a project by Conceição Silva, dated 1955 (7), that utilized an old garage in the Largo Rafael Bordallo Pinheiro, at n.13 - 15. The identity of the space was defined by a helical ramp as a key element of the composition that connected the store's three floors, very reminiscent of Italian modern eccentric architecture (Figure 4c). The facade, breaking away from the Pombaline-style design, opened to the outside in a burst of modernity by featuring a large glass area, into which the door was framed (Figure 4a). Rampa's doorframe, a reinforced concrete structure covered with ceramic tiles designed and painted by Querubim Lapa, conceived to sustain an all-glass façade (Figure 4b), became a key architectural element of the Modern Movement in Portugal, both in a historic and symbolic way. It was the single solid visual element in the composition and the ceramic tiles contained figuration allusive to the context such as two female full-body images that were placed on each side of the frame as a reinterpretation of Figuras de Convite (8) (Welcoming Figures) receiving visitors (Figure 5). The doorframe, in apparent suspension given the immateriality of the glass, allowed one to see it from every angle like a freestanding element. The door handles were made of ceramic plates with a stylized representation of hands (Figure 6) (9). They were suspended in the transparency of the glass, as they greeted the person who was grasping them.

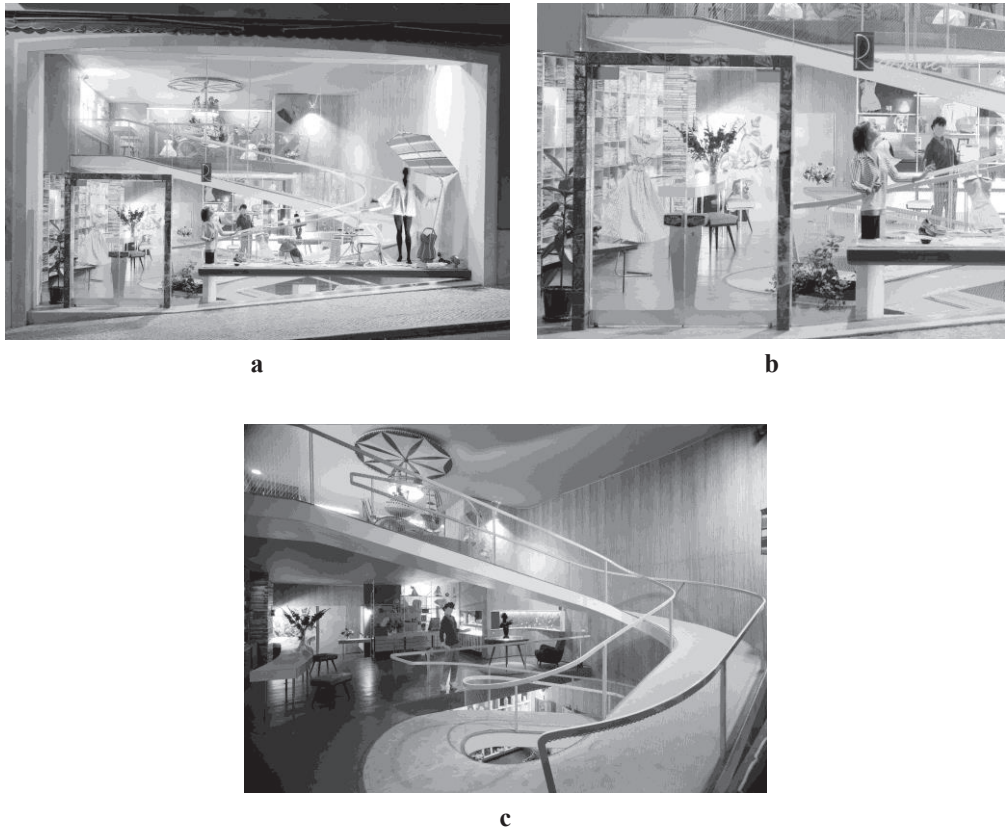


Figure 4: The Rampa store, Lisbon, 1956. Photograph Estúdio Novais, 1956, Calouste Gulbenkian Foundation.



Figure 5: The doorframe of the Rampa store. a) and b) photograph José Manuel Fernandes architect, 1980; c) detail from the doorframe of the Rampa store. Photograph Rita Gomes Ferrão, 2015.

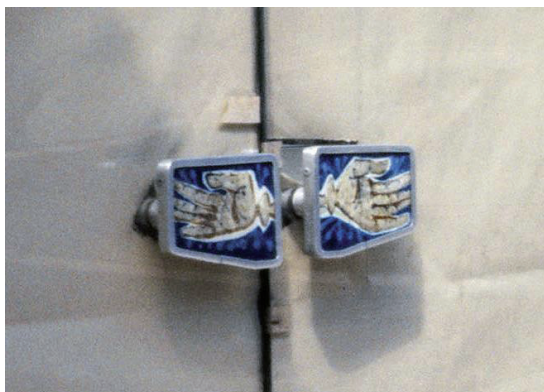


Figure 6: Door handles of the R:pa store. Photograph Ana Lopes de Almeida, 1980, Calouste Gulbenkian Foundation.



Figure 7: Detail from The Girls panel of Campolide Primary School, 1956. Photograph Rita Gomes Fer:o, 2014.

Following an approach similar to the one seen on the Campolide Primary School's panels (Figure 7) (a project of the same year by architect Pires Martins) (10), although with higher chromatic density, one could identify vegetable and animal elements, in particular birds (Figure 8b-c) and fish. Without forgetting the ironic remark of the old saying "In life big fish eat little fish" (Figure 8a), a subject Querubim exhibited for the first time in a painting shown at the Voz do Operário Fine Arts Exhibition, in 1953. That theme would become a recurring presence in his future production. It illustrated a Latin proverb making reference to injustice in an absurd world where the strongest insistently feed on the weak. The theme appears in 1556 in a drawing by Pieter Bruegel, The Elder (c. 1525-1569), inherited from the Hieronymus Bosch's (c. 1450-1516), "The Temptation of Saint Anthony" (c. 1495-1500). His concerns about social injustice were to prevail

in Querubim’s work, however, his language acquired symbolic universal outlines, moving away from the illustrative qualities featured in the Neo-Realist painting.

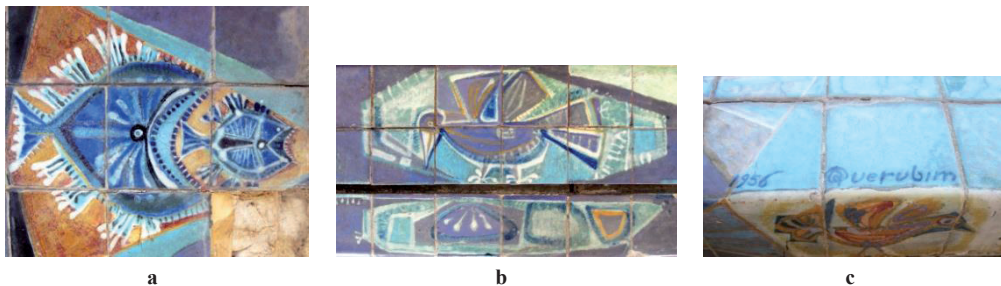


Figure 8: Details from the doorframe of the Rampa store. Photograph Rita Gomes Ferrão, 2015.

The Rampa store and its doorframe would be immortalized in “Verdes Anos” (1963), filmed by Director Paulo Rocha (1935-2012), in the inaugural movie of the Portuguese Cinema Novo movement. The modern architecture framed the protagonists, who were shown visiting the store and looking closely at the doorframe (Figure 9). It was an image of the new city, now long gone and destroyed by time. Notwithstanding it was saved by the cinema, albeit in black and white.



Figure 9: Film stills from “Verdes Anos”, Paulo Rocha, 1963.

Initially intended for selling articles for men, women and children, the Rampa store would also be committed to the exhibition and sale of art work, furniture and exclusive designs. The store was under the guidance of Conceição Silva, who was attentive to the trends of the international market and worked closely with Aníbal Camacho Ribeiro, the owner of the establishment. The Rampa would exhibit works by various artists such as the editions of the Cooperativa Gravura; furniture designed by Conceição Silva, some of it integrating paintings by Sá Nogueira (1921-

2002) (Figure 10b); manufactured glass made in Marinha Grande by Júlio Pomar (1926-2018), Alice Jorge (1924-2008), Hansi Staël (1913-1961) (11) and Carmo Valente (1930-2011); paintings by Sá Nogueira, João Hogan (1914-1988), Lima de Freitas (1927-1998), Carlos Calvet (1928-2014) and Nikias Skapinakis (n.1931) (Figure 10b); ceramics (Figure 10a) by Júlio Pomar, Alice Jorge, Bartolomeu Cid dos Santos (1931–2008), Manuel Cargaleiro (b. 1927), Querubim Lapa and Cecília de Sousa (b. 1937), who held there her first solo exhibition in 1957(12). Many other exclusive designs could be found in Rampa, as Conceição Silva was in charge of contacting the artists and always had new ideas to propose.



a



b



c

Figure 10: Interiors of the Rampa store, showing ceramics, glass, painting and furniture, 1956. Photograph Estúdio Novais, Atelier Conceição Silva's archive.

Confirming his desire to stimulate the creation of an internal market for art and design objects the architect suggested that Querubim Lapa should create a number of ceramic pieces intended to be exhibited there. Primarily of anthropomorphic and zoomorphic characters, those objects constituted a body of ground-breaking work by reinventing the traditional utilitarian ceramics. Especially the jugs (Figure 11), reckoned as a revisit to Rafael Bordallo Pinheiro's (1846-1905) caricature pieces; for instance, the "Cabeça de Chinês" (Chinese Head) and the "Toureiro" (Bullfighter) teapots; as well as the British Toby Jugs. That production was divided into three types: exclusive design wheel-thrown ceramics by the potters José Sanches and his son Ricardo Sanches at the Viúva Lamego factory, manipulated and painted by the artist; cast pieces from the author's original models and others from the factory catalogue, both painted by the artist. Later, in 1960, Querubim Lapa held his first solo exhibition featuring painting, printmaking and ceramics at the Cooperativa Gravura headquarters (Figure 12). Once more, the role of Conceição Silva was fundamental, by visiting the exhibition with the José Azeredo Perdigão (1896-1993), President of the Gulbenkian Foundation, he ensured some of the pieces were acquired to the Foundation collections and Perdigão's family.



Figure 11: Jugs, Querubim Lapa, 1956. Photograph Nuno Lopes Cardoso, 2015.



Figure 12: Francisco da Conceição Silva, Querubim Lapa and José Azeredo Perdigão at the artist's solo exhibition in the Cooperativa Gravura headquarters, 1960. Photograph CEQL.

Rampa can be considered a “felicitous room” in the sense it was designed not only to fulfil a need but also to fulfil the dream of building modernity, a place where art, design and architecture could be shown together as complementary languages that could not exist one without each other. Conceição Silva conceived the store as an experimental space, creating a dynamic and playful architecture that broke the rules of the past, the tradition of late eighteenth century Lisbon, and opened to the exterior without concealing anything. Apparently, there was no secret beyond the door, only an inviting new world.

Like in the church mentioned in Fritz Lang's movie, a generation of artists and designers believed a “miracle” could be performed inside the Rampa store, the “miracle” of Modernism. This believe was empowered by the way the transparent facade was designed, as the doorframe worked like a portal between the common world and what was perceived to be a promise of a better future. In Medieval churches the profane world is separated from the sacred world by the portico which, both in Romanic and Gothic temples, is an element full of information, preparing the believer to what he is going to encounter inside. The Rampa’s doorframe symbolically works in the same way, as if the store was a temple for the believers in modernity.

As the faith in modernity faded away, Rampa submerged into slow decadence. After the political changes occurred in 1974, Conceição Silva moved his studio to Brazil where he started a new life. With the awake of the post-modern era and the real estate speculation, Rampa could not resist and was demolished in 1980, in spite several efforts to save it. By the end of that year an auction was held (Figure 14) that included all the furniture and several artworks: a large piece in hammered copper that used to top the fireplace (Figure 10c), by Jorge de Almeida Monteiro (1908-1983); a chandelier in the shape of a merry-go-round that was part of the children section (Figure 13), by António Alfredo (1932-2000); and, of course, the doorframe by Querubim Lapa.



Figure 13: The Rampa store children’s section, 1956. Photograph Estúdio Novais, Atelier Conceição Silva’s archive.

The iconic piece did not meet a buyer but found a savior, as it was taken away before destruction. Vanished for thirty-five years, the doorframe was forgotten and only Querubim still believed that it was in a safe place. In 2015, when we were preparing an anthological exhibition of Querubim’s early work, many of it originally shown at Rampa, the doorframe was found in an old garage. The years had not been generous to it; it was in very poor condition and needed deep restoration.



Figure 14: The Rampa store auction announcement. Photograph José Manuel Fernandes architect, 1980.

After suffering a conservation intervention (Figure 15) supervised by the artist, Rampa's doorframe was finally exhibited, in October 2015, recovering its portal quality, as it was capable of opening an entrance to a long lost era. The exhibition "Querubim Lapa: Primeira Obra Cerâmica, 1954-1974" (Querubim Lapa: Early Ceramic Work, 1954-1974), held at Objectismo gallery (Figure 16), Lisbon, created the possibility for the piece to be acquired, however there was no private or public institution interested in buying it. Although some museums declared interest, they did not have the needed financial means to acquire the piece so, as soon as the exhibition closed, back to the old garage it went, much to the frustration of the artist, who hoped for the recognition of his artwork; of the curator (13), who knew the historical importance of the piece and longed for it to belong to a public collection; and of the gallerist, who was not able to recover his investment.



Figure 15: Querubim Lapa and aspects of the conservation intervention in the Rampa store doorframe by Oficina do Castelo, 2015. Photographs Oficina do Castelo.

In 2018, Objectismo gallery insisted on showing the Rampa's doorframe again, at Feira de Arte e Antiguidades de Lisboa (Lisbon Art and Antiques Fair), this time the press took notice of the situation (14) elevating the pressure on public institutions. Finally, MUDE – Museu do Design e da Moda (MUDE – Design and Fashion Museum), was able to reunite the necessary means to acquired the doorframe and is currently planning its integration in the museum architecture promoting a permanent display (15).



Figure 16 : Querubim Lapa and the Rampa store doorframe at Objectismo gallery, 2015.
Photograph Rita Gomes Ferrão.

Unfortunately, Querubim Lapa, deceased in 2016, no longer could testify the entering of his first tridimensional piece for architecture on a public museum collection, but the power of his artwork remains.

Like the “felicitous rooms” collected by the architect in Fritz Lang’s movie, Rampa had a tragic fate, only to be rehabilitated by the permanence of its doorframe working as a memory trigger.

Today, when the history of Portuguese Modernism after World War II is still being made, and there is a growing interest for mid-century modern design, we can only imagine how rewarding it would be if the Rampa store was still there, fulfilling its function not only as a store but especially as gem of Modernism.

Notes

1 - In Binário: arquitectura construção equipamento, n.29, Lisboa, February, 1961, p.85.

2 - The SPN (Secretariat of National Propaganda), created in 1933, was the public body responsible for political propaganda, information, media, tourism, and cultural action, during the Estado Novo regime in Portugal. After World War II it was designated SNI (Serviço Nacional de Informação - National Information Secretariat for Popular Culture and Tourism). In 1968 it was once again renamed to SEIT (Secretaria de Estado da Informação e Turismo - Secretariat of State Information and Tourism), having been extinguished on April 25, 1974.

3 - Refer to FRANÇA, José Augusto – *Arte em Portugal no Século XX*. Lisboa, Livraria Bertrand, 1974.

4 - During that time, at the beginning of his professional career, the Portuguese designer Daciano Costa used the name Daciano Henrique to sign many of his paintings.

- 5 - In Revista Arquitectura. N. 29, 2ª série, Ano XXV, Lisboa, October, 1953, p.18.
- 6 - The building was demolished.
- 7- Refer to PEREIRA, Michel Toussaint Alves – *Francisco da Conceição Silva Arquitecto 1922-1982*. Lisboa, SNBA, 1987. p.34-35
- 8- Welcoming Figures are typical of Portuguese tiles, since the 18th century. Conceived on a natural scale, they usually represented servants, warriors or ladies, placed in entrances or steps of stairs, where they received visitors with a look or gesture that indicated the way, inviting them in.
- 9 - The door handles are lost until today.
- 10 - Refer to HENRIQUES, Paulo; MECO, José; PEREIRA, João Castel-Branco - *Querubim, obra cerâmica, 1954-1994*. Lisboa, Sociedade Lisboa 94; Milão, Electa, 1994. HENRIQUES, Paulo; MECO, José; PORFÍRIO, Luís; SANTOS, Rui Afonso - *Cerâmicas: Querubim Lapa*. Lisboa, Inapa, 2001. p.14.
- 11 - Refer to SANTOS, Armando Vieira – *A propósito de uma exposição de vidros de Júlio Pomar e Alice Jorge*. Comércio do Porto, 11 Dez, p.5 and LEAL, João – *Exposição de Vidros*. Lisboa, Arquitectura, n.57-58, Jan-Fev, 1957.
- 12 - Refer to HENRIQUES, Paulo; CALADO, Rafael Salinas; SOBREIRO, Rita – *A minha segunda casa... Cecília de Sousa: obra cerâmica 1954-2004*. Lisboa, Museu Nacional do Azulejo, 2004. p.12.
- 13- The curator of the exhibition was Rita Gomes Ferrão, author of this essay and of the book *Querubim Lapa: Primeira Obra Cerâmica 1954-1974*. Lisboa, Objectismo, 2015, published at the occasion.
- 14 - Refer to HORTA, Bruno - *Museus públicos não quiseram obra de Querubim Lapa que está à venda por 35 mil euros*. Observador, 19 Apr. 2018. 16:13h
- 15 - Refer to *Museu do Design adquiriu pórtico de Querubim Lapa criado para a Loja Rampa*. Diário de Notícias, 2 Oct. 2018. 17:56h

Beneath sacred land: glazed pottery from the old Church of La Concepción in Zamora

Uxue Sanchez-Garmendia

Department of Analytical Chemistry, Faculty of Science and Technology, GPAC, Built Heritage Research Group, University of the Basque Country UPV/EHU, Bilbao, Basque Country, Spain, e-mail: uxue.sanchez@ehu.eus

Estefania Calparsoro

GPAC, Built Heritage Research Group, Faculty of Arts, University of the Basque Country UPV/EHU, Vitoria-Gasteiz, Basque Country, Spain, e-mail: estefania.calparsoro@ehu.eus

Gorka Arana

Department of Analytical Chemistry, Faculty of Science and Technology, University of the Basque Country UPV/EHU, Bilbao, Basque Country, Spain, e-mail: gorka.arana@ehu.eus

Javier G. Iñáñez

GPAC, Built Heritage Research Group, Faculty of Arts, University of the Basque Country UPV/EHU, Vitoria-Gasteiz, Basque Country, Spain, e-mail: javier.inanez@ehu.eus

SUMMARY: A set of 14 archaeological ceramics, including tin-lead glazed, micaceous and “Duque de la Victoria” type ceramics, from 15th-16th centuries recovered from the rests of the goldsmithing workshop beneath the Church of La Concepción (Zamora, Spain) was archaeometrically characterized by Inductively Coupled Plasma Mass Spectrometry (ICP-MS), X-ray Diffraction (XRD) and Scanning Electron Microscopy (SEM). Ceramic provenance has been established as being mainly from local origin with some examples from other regional production centers.

RESUMEN: Se ha caracterizado arqueométricamente una colección de cerámicas arqueológicas compuesta de mayólicas, micáceas y una del tipo “Duque de la Victoria” de los siglos XV-XVI recuperada de los restos de un taller de orfebrería que se encontraban debajo de la Iglesia de Nuestra Señora de La Concepción de Zamora. La caracterización se ha llevado a cabo mediante Espectrometría de Masas por Plasma Acoplado Inductivamente (ICP-MS), Difracción de Rayos X (DRX) y el Microscopio Electrónico de Barrido (MEB). La proveniencia de las cerámicas se ha establecido siendo mayoritariamente de origen local con algunos ejemplos de otros centros productores de la región.

KEY-WORDS: pottery, glaze, chemical analysis, mineralogical analysis, post-medieval

INTRODUCTION

Among the manufactures the human being has been creating throughout the History, pottery has occupied a prominent role. In the late Middle Ages and Modern era, this pre-industrial activity was an important craft occupation and usually professionally regulated by the guilds [1-2]. In many medieval and early modern era cities, were local potters who satisfied principally the basic needs related to cooking and food consumption as well as buildings materials in a local market context, although regional trade networks were also of relevance in terms of pottery consumption [3].

The city of Zamora lies in the north-western area of the Iberian Peninsula, belonging to the province of Zamora, which borders León from the north, Valladolid from the east, Salamanca from the south and Orense and Portugal from the west (Figure 1). The potting tradition in the city of Zamora runs since immemorial times until present days. Besides, post-medieval pottery from Zamora keeps a strong tie with late medieval Castilian ceramic tradition, specifically in relation to typologies. Thus, Zamoran pottery often shows open typologies, like plates and porringers, as well as closed ones, like jars and cooking pots [4].

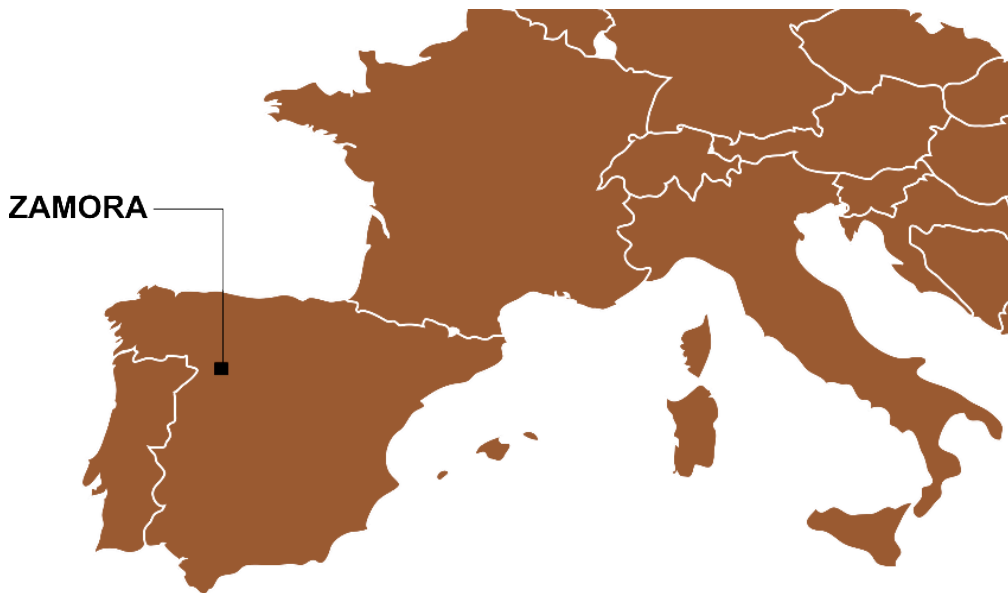


Figure 1: The position of Zamora in the map.

During the past two decades, numerous excavations have been conducted in the city of Zamora. To name some of them, two were carried out at the places corresponding nowadays to the Provincial Historical Archive [5-6] and the Public Library of the State [6-7], another at the Ethnographic Museum [7] and the last at the area known as Olivares [6-8]. In the same site, where nowadays lies the Provincial Historical Archive, there was an old convent called *Convento de Nuestra Señora de La Concepción*, while in the adjacent plot, where the Public Library of the State was constructed, there was the church known as *Iglesia de Nuestra Señora de La Concepción* [6-8]. Although these two ancient buildings were rehabilitated and partially demolished for building up the new public edifices while keeping some parts of the facades, fortunately these construction fever enabled the archaeological works that revealed a piece of Zamoran history. Thanks to these archaeological interventions, the different phases of occupation that have undergone the old convent and church have been studied [5-7]. In 1626, the religious community of the Conceptionists moved to the buildings known as *Casas de Gonzalo de Valencia* in the Claudio Moyano square, in the heart of the downtown area, which would be the Convent of La Concepción and their home for the next two centuries. Later on, the construction of the church started in 1672 and lasted until 1676 [6]. In 1837, the Conceptionists were forced to leave as a result of a general confiscation ordered by the Spanish government, known as Mendizabal's confiscation, and these two buildings passed to the property of the state [6]. Moreover, archaeological works also shed light on the existence of evidences from earlier dates beneath the church. On the one hand, numerous holes stuffed with medieval hispanomuslim ceramics from

the ages and dated before the 13th century were documented [7]; and on the other hand, evidences of a goldsmithing workshop that was active between 13th and 16th centuries were also found [6].

In the course of these fieldworks an important set of archaeological materials, including an important set of ceramics, has been recovered. These remains, accompanied by the available documentation, the analysis of the stratigraphic secuencia, and its study, have allowed the archaeologists to be capable of dating the different structures appeared beneath the convent and the church as belonging to the period between the late Middle Ages and the Modern Ages [6-7]. Those ceramic vessels unearthed at the goldsmithing workshop remains can be subdivided in two groups: glazed and unglazed ceramics. Among the last ones, common and micaceous types, which constitute the majority amongst the unglazed pottery found, are distinguished [7]. When it comes to the glazed ones, although in general they show similar stylistic attributes to those from Valladolid [7], the origin may be attributed to Valencian area (Manises, Valencia) according to stylistic features and chronology [7]. This fact may confirm the existence of a comercial exchange network between Zamora and Valencia during late Medieval times [7]. Another typology of the pottery identified is the so-called *Duque de la Victoria* type. This name corresponds to the homonymous street in Valladolid where some pottery workshops were found and dated back to the late Medieval period as well. Six fragments of this type have been recovered in the goldsmithing workshop area, and are characterized by a red slip that gives them a characteristic brightness [7].

As regards the archaeometrical state-of-the-art on the ceramic materials from Zamora, few studies have been carried out. Among them, it has to be highlighted the ethnoarchaeometrical investigation about the cooking pot production of Pereruela, a small village near Zamora and famous by its cooking pot productions. In this study, contemporary production and clay supply from a complex geological context was assessed, revealing a very complex chemical fingerprint according to different family recipes in the village [9]. Another relevant study is the one carried out by Iñáñez and collaborators [10] who characterized the ceramics recovered in the old workshops of the area known as Olivares in the city of Zamora. In this study, authors identified three different chemical groups and their fabrics related to the ceramic production of Olivares (Table 1) [10]. Along these lines, a fabric is the final result that reaches the paste, after completing the technological process of the fabrication of the ceramics [11], which can be observed by the array of mineralogical composition and paste textures.

Table 1: Summary of the groups and fabrics previously identified in the site of Olivares

GROUP	SITE	TPOLOGY	FABRICS
Z-1	OLIVARES	Unglazed, glazed failures, tin-lead glazed, honey-glazed	F-I, F-II
Z-2	OLIVARES	Micaceous, micaceous glazed, micaceous honey-glazed	F-I, F-II
Z-3	OLIVARES	Unglazed, tin-lead glazed	F-I, F-IIa / F-IIb, F-III, F-VI

So as to fill the existing lack of information, the purpose of this work not only is to characterize the pottery from the archaeological site of the Church of La Concepción and the prior goldsmithing workshop, but also to assess the provenance of local or regional origin of the ceramics, shedding light on the regional trade and local consumption patterns.

ANALYTICAL METHODOLOGY

A set of 14 archaeological ceramics, including tin-lead glazed, micaceous and *Duque de la Victoria* type ceramics from 15th-16th centuries recovered from the remains of the goldsmithing workshop beneath the Church of La Concepción (Zamora, Spain) was archaeometrically characterized. Among them, 7 are tin-lead glazed ceramics: 2 are decorated with blue motives, one with green and brown and the last one with black and green motives. Another 6 are micaceous, and the last one is a fragment of *Duque de la Victoria* type (Figure 2 and Table 2). Ceramics were analyzed by means of Inductively Coupled Plasma Mass Spectrometry (ICP-MS), X-ray Diffraction (XRD) and Scanning Electron Microscopy (SEM).

Table 2: Anids, typologies and decorations of the 14 ceramics from the Church of La Concepción.

ANID	TYOLOGY	DECORATION
ZMR037	Micaceous	Undecorated
ZMR038	Micaceous	Undecorated
ZMR039	Micaceous	Undecorated
ZMR040	Tin-lead glazed	Undecorated
ZMR041	Tin-lead glazed	Undecorated
ZMR042	Micaceous	Undecorated
ZMR043	Micaceous	Undecorated
ZMR044	Micaceous	Undecorated
ZMR045	Tin-lead glazed	Green and black on white
ZMR046	Tin-lead glazed	Blue and white
ZMR047	Tin-lead glazed	Blue and white
ZMR048	Tin-lead glazed	Green and brown on white
ZMR049	Tin-lead glazed	Undecorated
ZMR050	Duque de la Victoria	Undecorated



Figure 2: The set of 14 archaeological ceramics.

Chemical analysis procedure by ICP-MS

In the present study, ~10 g of each collected ceramic was powdered using a Herzog HSM 100 pulverizer milling machine equipped with tungsten carbide twin eccentric disks for 30s (HERZOG Automation Corp.). Prior to grinding, glazes and exterior surfaces were mechanically removed by means of a tungsten carbide abrading tool, leaving only the inner part of the ceramic for analysis. This step served to minimize contamination of the ceramic matrix by glaze and soil. Powdered specimens were stored in polyethylene vials for transport to the laboratory.

Sample manipulation and ICP-MS analysis were carried out in a clean laboratory. Commercial reagents (Merck Pro Analyti hydrofluoric acid 50.2% and nitric acid 69.8%) were purified in a clean room by sub-boiling quartz-distillation (HNO_3) and Teflon bottle-distillation (HF). Ultrapure water (resistivity $\geq 18.2 \text{ M}\Omega$) was obtained by a MilliQ water purification system (Millipore) and polishing by reverse osmosis (Nanopure Barnstead). The flux agent was LiBO_2 (Anhydrous, For Analysis Grade Pure) of Corporation Scientifique Claisse, with solution of 50% LiBr (Merck Suprapur) in deionized water used as antiadherent. Certified Reference Materials (CRM) of geological nature were obtained from the Geological Surveys of Japan: andesite JA2, granodiorite JG-1a, granite JG-2, and basalt JB-3.

The solutions of unknown samples and Certified Reference Materials for external calibration, validation of the method and preparation of procedural blanks were obtained by alkaline fusion with LiBO_2 in Pt–Au crucibles, followed by acid dissolution of the melt. The fusion process is as follows: 250 mg of sample and 500 mg of flux are put into the crucible with three to four drops of LiBr solution as non-wetting agent. The mixture is fused using a Claisse propane fusion instrument (Corporation Scientifique Claisse, Québec, Canada). The melted mixture is poured automatically onto a weighed polypropylene beaker containing 100 mL HNO_3 1M, with a few

drops of HF to ensure stability of the HFSE. The acid solution is stirred ca. 10 min to ensure total dissolution [12]. This primary solution is diluted gravimetrically to ca. 1:200 in HNO₃ 1%.

Trace element analysis was carried out with an Nexion 300 ICP/MS (PerkinElmer, Ontario, Canada), provided with a Oneneb pneumatic concentric nebulizer (Agilent), cyclonic spray chamber and standard nickel cones. Preparation of calibrants and analysis of samples were done inside a clean room (class 100). Argon (99.999%, Praxair, Spain) was used as carrier gas in the ICP/MS measurements. The concentrations of a wide range of analytes ²⁷Al, ³¹P, ⁸⁸Sr, ¹²⁰Sn, ⁹⁰Zr, ⁹³Nb, ¹³³Cs, ¹³⁷Ba, ¹³⁹La, ¹⁴⁰Ce, ¹⁴¹Pr, ¹⁴²Nd, ¹⁴⁷Sm, ¹⁵³Eu, ¹⁵⁸Gd, ¹⁵⁹Tb, ¹⁶⁴Dy, ¹⁶⁵Ho, ¹⁶⁶Er, ¹⁶⁹Tm, ¹⁷⁴Tb, ¹⁷⁵Lu, ¹⁸⁰Hf, ¹⁸¹Ta, ²⁰⁶⁺²⁰⁷⁺²⁰⁸Pb, ²³²Th and ²³⁸U (Internal standards: In and Bi) were analyzed in standard mode; while ²³Na, ²⁴Mg, ²⁸Si, ³⁹K, ⁴⁴Ca, ⁴⁷Ti, ⁵¹V, ⁵²Cr, ⁵⁵Mn, ⁵⁶Fe, ⁵⁹Co, ⁶⁰Ni, ⁶³Cu and ⁶⁶Zn (Internal standard: In) were analyzed in collision mode with He as cell gas.

The plasma operating conditions such as the nebulizer flow rate, the position of the torch and the ion lens voltages of the instrument were optimized everyday prior to any experiment with a 10 ng/mL standard solution of Mg, Rh, In, Ba, Pb and U. The nebulizer gas-flow rate was optimized to obtain a good compromise between high sensitivity and low oxide levels (lower than 2.5% for CeO/Ce). Sample introduction and experimental conditions for the data acquisition of de ICP-MS are collected in Table 3.

Table 3: Sample introduction and experimental conditions for the data acquisition of the ICP-MS.

SAMPLE INTRODUCTION AND EXPERIMENTAL CONDITIONS	
Nebulizer gas flow	0.90-1.00 L/min
Plasma gas flow	18 L/min
Auxiliar gas flow	1.2 L/min
RF power	1600 W
Cell gas flow (He)	4.0 mL/min
Dwell time	50 ms
Integration time	1000 ms
Sweeps	20
Readings	1
Replicates	3

Mineralogical analysis procedure

Powder ceramic samples were mineralogically characterized by powder X-ray diffraction (XRD), using a powder diffractometer PANalytical Xpert PRO that incorporates a copper tube ($\lambda_{\text{CuK}\alpha\text{media}} = 1.5418 \text{ \AA}$, $\lambda_{\text{CuK}\alpha 1} = 1.54060 \text{ \AA}$, $\lambda_{\text{CuK}\alpha 2} = 1.54439 \text{ \AA}$), vertical goniometer (Bragg-Brentano geometry), programmable divergence aperture, automatic interchange of samples, graphite secondary monochromator and PixCel detector.

The measurement conditions were 40 kV of voltage and a current of 40 mA, with an angular range (2θ) scanned between 5 and 70°. Mineral phases present in the samples were identified

using X'pert HighScore (PANalytical) software in combination with the powder diffraction file database PDF2 (International Centre for Diffraction Data – ICDD, Pennsylvania, USA).

Scanning Electron Microscopy analysis procedure

The SEM study was conducted on 4 glazed ceramics after being transversally cut, embeded in epoxy resin and metalographically polished. Samples were gold coated and examined under an EVO 40 Carl-Zeiss SEM coupled to an energy dispersive X-ray analyzer (EDS). Sample examination was conducted at 20 kV and a current of 500 mA under full vacuum conditions. The elemental composition of decorative coatings was determined by an electron dispersive spectrometry (EDS) analysis of areas corresponding to each color, using an X-Max (Oxford Instruments) equipment. The working distance ranged between 7.5 and 10.5 mm. The EDS spectra were acquired and treated using the INCA software (Oxford Instruments).

RESULTS AND DISCUSSION

The statistical analysis of the data followed Aitchison's approach and Buxeda's observations on compositional data [13-16]. The statistical procedure consists of the use of ratios of logarithms obtained by dividing all the components, in this case chemical components, by the component that introduces the lowest chemical variability to the entire set of specimens taking into consideration, overcoming the compositional data problem called "close to unit sum", when data necessarily must sum 100%. Moreover, the use of logarithms compensates for differences in magnitudes between major elements, such as Al or Fe, and trace elements, such as the lanthanide or rare earth elements (e.g. La, Ce, Sm, etc.) and log-transformed data serve to make the distributions of geochemical data more nearly normal. Finally, the log ratio transformation also highlights possible perturbations in the chemical data as a result of diagenesis, contamination, or other alteration processes [16].

The data were examined using an array of multivariate statistical procedures. The application of multivariate statistical techniques to multielemental chemical data facilitates identification of compositional groups. Therefore, similarity of individuals, and subsequently their hypothetical provenance according to the provenance postulate [17], was tested using squared Euclidian distances. In order to assess the provenance of unknown samples from the Church of La Concepción, they were compared against well-known archaeometrical reference groups from the main productions of those from the site of Olivares, in the outskirts of the city of Zamora (Table 1) [10]. Thus, Z-1, Z-2 and Z-3 are the groups defined in a previous study about the workshop of Olivares. On the one hand, Z-1 is mainly composed by glazed and glazed failures, as well as one majolica ceramic; on the other hand, Z-2 group is composed by micaceous ceramics. Finally, Z-3 group is made out of tin-lead glazed ceramics, kiln failures and kiln furniture [10].

Although sample preparation was conducted under great care to minimize the analytical error, the potential for contamination exists nonetheless and a conservative approach to data interpretation is warranted. Thus, Co was removed from consideration during the statistical treatment because cobalt is a known binder in the tungsten carbide cell used to grind the samples. Moreover, Pb and Sn were not used in the statistical treatment since these elements are major components of the glaze composition for tin-glazed and lead glazed wares. In addition, P₂O₅ was also neglected in statistical routines due to its high variability and potential as a key-role element in alteration processes in underwater environments [18-19].

The results are summarized in Figure 3, graphically displaying Hierarchical Cluster Analysis (HCA) that was performed by the squared Euclidian distance and the centroid algorithm using centered log-ratio transformation (CLR) on the CaO, Al₂O₃, Zr, Cs, Ba, Sr, La, Ce, Pr, Nd, Sm,

Eu, Gd, Dy, Ho, Er, Tm, Lu, Hf, Ta, Th, MgO, SiO₂, K₂O, TiO₂, V, Cr, Fe₂O₃, Ni, Yb, and Nb subcomposition and using the geometrical mean as divisor.

Examination of the resulting dendrogram shows a clear 4-group structure that corresponds to the different productions identified in La Concepción and the Olivares productions already established (Figure 3).

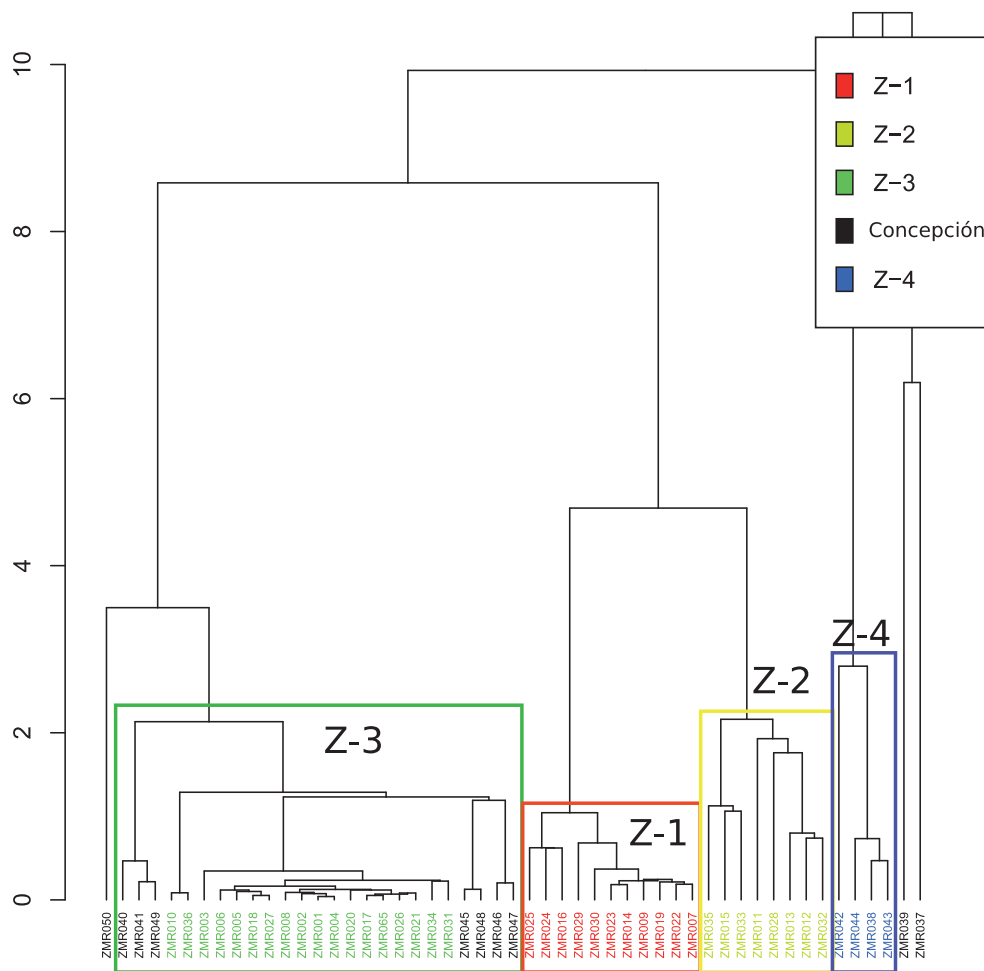


Figure 3: Statistical analysis (dendrogram) of the ICP-MS results. It shows a clear 4-group structure that corresponds to the different productions identified in La Concepción (Z-3 and Z-4) and Olivares productions (Z-1, Z-2, Z-3)

Most of the groups show clear and defined cuts from the rest. Moreover, most of the samples belonging to a given cluster also exhibit a certain degree of homogeneity within their chemical composition, as can be observed by their fusion links, pointing to a similar composition. Interestingly, all of the tin-lead glazed ceramics unearthed at the Church of La Concepción (ZMR040, ZMR041, ZMR045, ZMR046, ZMR047, ZMR048 and ZMR049, which are labeled as “Concepción” in Figure 3) show a chemical fingerprint compatible with the already identified Z-3 group from Olivares workshops. In this way, the ceramics that form this group, are calcareous despite showing a broad range of CaO content, from 5.73 wt% to 19.38 wt% (Table 4). Thus, this amount of CaO, along with relatively low Fe₂O₃ content (mean 4.3 wt%), provides buff/pink color to the ceramic pastes in oxidizing firing conditions [20].

Furthermore, another set of ceramics has been identified into a new group called Z-4 (ZMR038, ZMR042, ZMR043 and ZMR044) all from the Church of La Concepción. All of them are unglazed and are, basically, cooking pots and serving vessels. Therefore, this group shows a non-calcareous clay paste, with CaO amounts around 1.90 wt%. In addition, Z-4 group shows high amounts of Al₂O₃, clearly linked to the high quantity of phyllosilicates (e.g. mica) and due to its optimal technical properties for thermal shock resistance.

Upon further examination, the dendrogram (Figure 3) also reveals the existence of three ceramics that do not match any of the paste reference groups identified in the workshop of Olivares nor La Concepción of the city of Zamora (ZMR037, ZMR039 and ZMR050). Two of these ceramics, ZMR037 and ZMR039, are of micaceous paste and, surprisingly, do not cluster together with Z-4 group that is also micaceous. This fact is evidenced by their lower content on Al₂O₃ and, at the same time, higher amounts of CaO, Sr and MgO for the outlier ceramics (Table 4). Likely, this two ceramics belong to another ceramic production from the renowned vicinity potting villages in the region, like Pererueta or Muelas del Pan. Finally, ZMR050 is also not linked to any of the already established chemical groups in Zamora due to higher values mainly on Al₂O₃, Ba, Ce, Cr, La and Fe₂O₃, as well as much lower CaO amounts (Table 4).

Mineralogically, ceramics from the Church of La Concepción of Zamora show two main different arrays of mineralogical distribution. Accordingly, there are two different types of pottery that, respectively, correspond to the two identified chemical groups in addition to the non-ascribed ceramics: calcareous majolica and non-calcareous (micaceous and non-majolica ceramics).

Interestingly, exactly 50% of the ceramics are calcareous, showing more than 13% of CaO content in most of the cases (ZMR040, ZMR041, ZMR045, ZMR046, ZMR047, ZMR048 and ZMR049). Besides, all the calcareous ceramics from La Concepción belong to the already established Olivares Z-3 chemical group. Along these lines, in this latter study [10], four different fabrics were previously identified for Z-3 (F-I, F-IIa, F-IIb, F-III and F-VI). However, after the reevaluation of the whole Z-3 group after the inclusion of the new ceramics from La Concepción, in total six different fabrics were defined: F-I, F-IIa, F-IIb, F-III, F-IV, F-V and F-VI. However, F-I, F-III and F-VI show only ceramics from Olivares, while F-IV and F-V have only ceramics from La Concepción. Nevertheless, the fabric F-II includes ceramics from both sites (Table 5).

Table 4: Average values for Zamoran (the Church of La Concepción) chemical groups by ICP-MS analysis. All values are expressed as ppm ($\mu\text{g}\cdot\text{g}^{-1}$) except oxides that are expressed as weight % (*std* stands for standard deviation and *conc.* for concentration).

	Z-3 (n=25)		Z-4 (n=4)		ZMR037	ZMR039	ZMR050
	mean	std.	mean	std.	conc.	conc.	conc.
Al₂O₃	14.14	3.06	24.67	2.10	22.52	23.21	22.32
Ba	386.25	69.18	304.93	24.77	291.25	458.94	605.83
CaO	6.97	5.74	1.90	0.90	0.10	1.13	3.48
Ce	71.70	12.49	47.65	4.69	92.42	82.15	94.81
Cr	55.22	11.72	21.80	0.95	14.30	29.87	93.03
Cs	8.02	3.14	30.66	4.11	10.85	10.90	9.87
Dy	4.73	0.69	5.68	0.72	4.14	4.99	5.89
Er	2.54	0.31	3.07	0.32	1.81	2.10	3.28
Eu	1.31	0.30	0.94	0.14	1.95	1.93	1.91
Fe₂O₃	4.30	0.72	2.48	0.12	2.12	2.85	7.47
Gd	5.84	0.98	5.68	0.66	7.46	8.01	7.80
Hf	5.45	1.62	4.86	0.27	2.85	3.19	4.46
Ho	0.79	0.08	0.93	0.13	0.59	0.72	0.97
K₂O	2.91	0.83	3.48	0.40	2.12	2.80	5.38
La	35.43	6.21	22.72	2.94	39.72	35.41	47.84
Lu	0.35	0.07	0.38	0.08	0.13	0.14	0.38
MgO	1.55	0.91	0.89	0.11	0.77	0.75	2.40
Nb	2.30	5.37	24.62	1.53	14.54	15.25	21.56
Nd	17.14	7.53	22.25	3.06	51.65	46.23	45.30
Ni	34.95	8.15	9.92	2.40	6.62	9.80	40.74
Pr	8.70	1.61	5.67	0.68	12.43	11.13	11.45
SiO₂	66.83	10.27	67.64	6.56	76.74	77.04	62.99
Sm	6.93	1.26	5.07	0.37	9.61	9.29	8.36
Sr	177.98	72.48	106.85	36.39	248.22	274.56	240.86
Ta	1.64	0.42	7.72	0.59	3.56	3.56	2.37
Th	12.68	2.05	8.41	0.39	7.79	9.00	17.97
TiO₂	0.68	0.18	0.28	0.02	0.22	0.34	0.82
Tm	0.38	0.06	0.50	0.07	0.25	0.28	0.52
V	62.31	14.17	24.20	1.57	22.15	30.46	99.10
Yb	2.49	0.35	2.96	0.40	1.65	1.76	3.22
Zr	245.73	89.60	211.07	12.79	95.70	117.45	212.37

Typical calcareous earthenware phase associations are identified in Z-3 of La Concepción. The main mineral phases that form the Z-3 ceramics are quartz, potassium feldspar, gehlenite and calcite (with the exception of ZMR046 and ZMR047). Besides, illite is present in F-IIa (ZMR045 and ZMR048) accompanied by plagioclase and diopside, providing an Equivalent Firing Temperature (EFT) in the range 850-900 °C (Figure 4). In addition, diopside is present in the fabric F-IV, which is formed by 3 ceramics (ZMR040, ZMR041 and ZMR049) providing an Equivalent Firing Temperature (EFT) in the range of 900-950 °C (Figure 5). Nonetheless, fabric F-V, formed by 2 ceramics (ZMR046 and ZMR047), shows plagioclase in addition to diopside but it doesn't have calcite. These phases provide an EFT ranging from 950 °C to 1000 °C (Figure 6).

Table 5: The interpretation made based on ICP-MS analysis and mineralogical analysis results.

GROUP	SITE	TYOLOGY	FABRICS	ANIDS
Z-3	CONCEPCIÓN / OLIVARES	Unglazed, tin-lead glazed	F-I, F-IIa / F-IIb, F-III, F-IV, F-V, F-VI	ZMR040, ZMR041, ZMR045, ZMR046, ZMR047, ZMR048, ZMR049 + samples from Z-3 Olivares [see 10]
Z-4	CONCEPCIÓN	Micaceous	F-Ia / F-Ib, F-II	ZMR038, ZMR042, ZMR043, ZMR044

The chemical group Z-4 is formed by four micaceous ceramics (ZMR038, ZMR042, ZMR043 and ZMR044). In this group, two different mineralogical fabrics have been identified: F-Ia and F-Ib, and F-II. Main mineralogical phases identified are quartz, potassium feldspar and illite. Specifically to the F-Ia fabric (ZMR038 and ZMR043) differs from F-Ib (ZMR042) due to the appearance of calcite in the latter one, both showing an EFT in the range of 800-850 °C (Figure 7 and 8). The ceramic from F-II (ZMR044) contains plagioclase and calcite, in addition to the main mineral phases previously described, providing an EFT in the range of 850-900 °C (Figure 9).

Furthermore, the rest two micaceous sherds (ZMR037 and ZMR039) and *Duque de la Victoria* type one (ZMR050), do not belong to any specific chemical group. When it comes to the two micaceous ceramics, they have the same phase associations as the F-I from Z-4 (quartz, potassium feldspar and illite) with an EFT in the range of 800-850 °C (Figure 10 and 11).

Finally, *Duque de la Victoria* type ceramic contains quartz, potassium feldspar, plagioclase and illite, providing an EFT around 850 °C (Figure 12).

Nevertheless, it is important to highlight the presence of calcite in some of the ceramics from the Church of La Concepción. Given the EFT temperatures identified and the fact that calcite decomposes after 650 °C, it is probable that its appearance is due to re-carbonation processes and secondary precipitations that could happen during the post-depositional period [11].

Summing up, the interpretation made based on ICP-MS analysis and mineralogical analysis results, is collected in the Table 5.

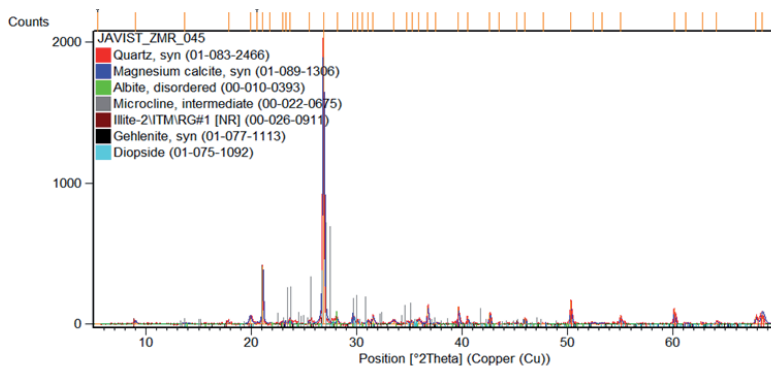


Figure 4: Reference diffractogram of the F-IIa, Z-3.

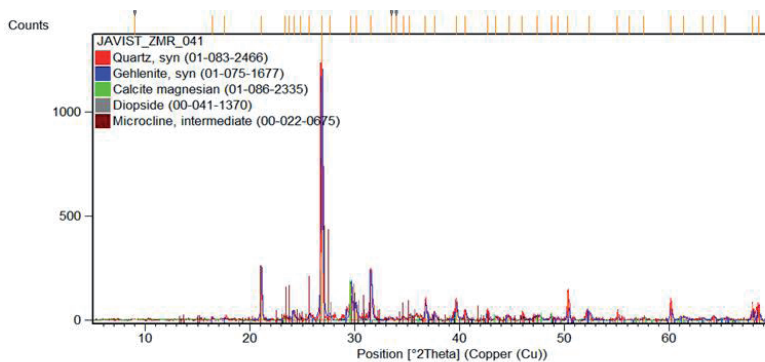


Figure 5: Reference diffractogram of the F-IV, Z-3.

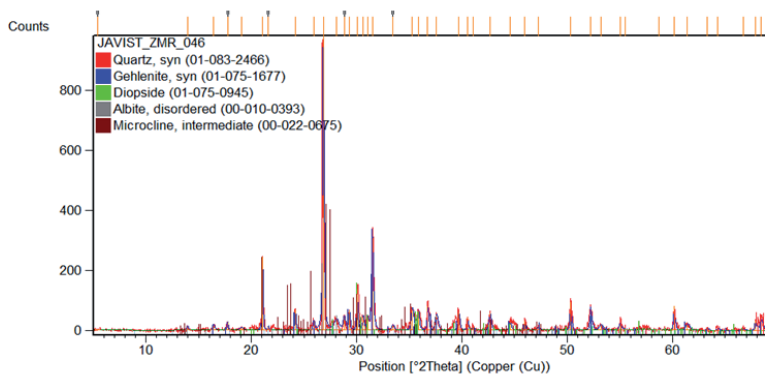


Figure 6: Reference diffractogram of the F-V, Z-3.

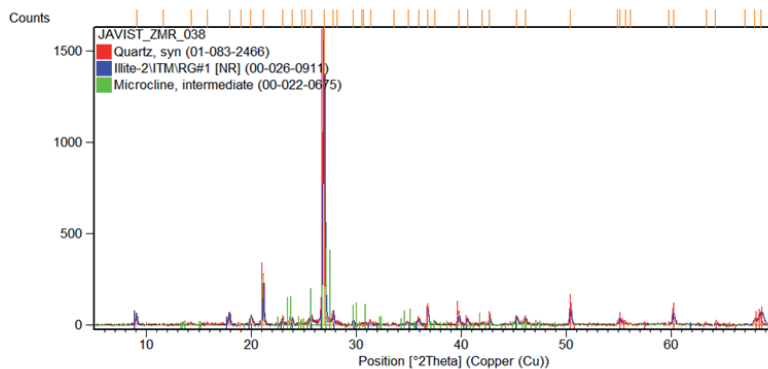


Figure 7: Reference diffractogram of the F-Ia, Z-4.

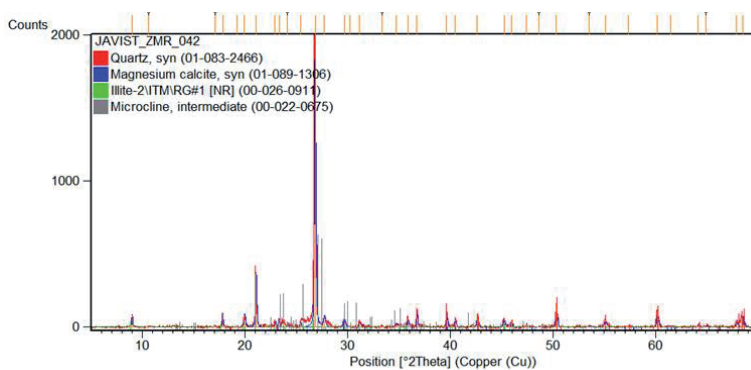


Figure 8: Reference diffractogram of the F-Ib, Z-4.

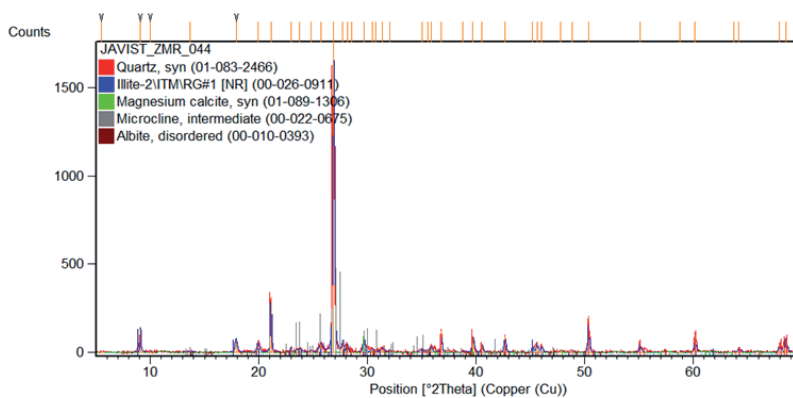


Figure 9: Reference diffractogram of the F-II, Z-4.

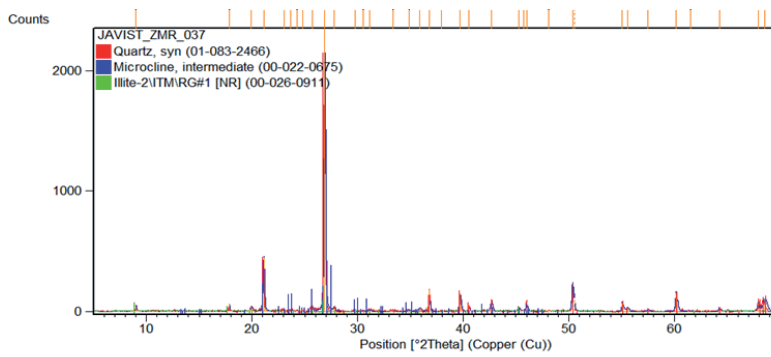


Figure 10: ZMR037.

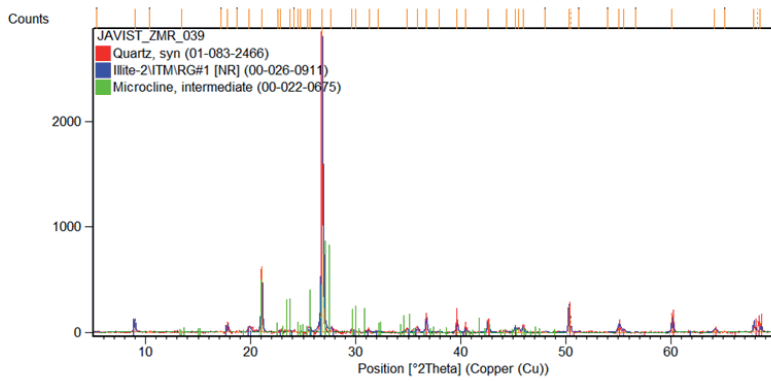


Figure 11: ZMR039.

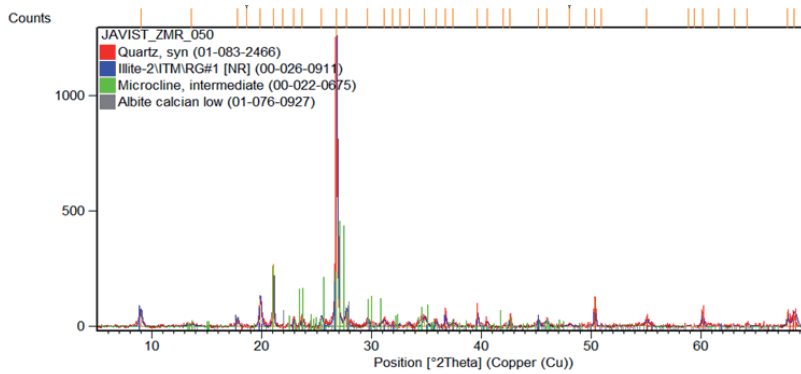


Figure 12: ZMR050, *Duque de la Victoria* type.

After chemical and mineralogical analyses, 4 glazed ceramics were selected for SEM-EDS study in order to deepen into the understanding of their glaze composition and pigment nature: ZMR045 (black and green on white decoration); ZMR046 (blue and white decoration); ZMR047 (blue and white decoration); and ZMR048 (brown and green on white) (Table 2).

According to SEM-EDS results of the glazed ceramics, all of the glazes analyzed are Pb and Si based. In addition, SEM-EDS enables for identifying Sn particles distributed thoroughly within the glaze. These crystals are likely cassiterite (SnO_2) and, along with some relicts of quartz and sometimes feldspars, help out for achieving the opaque white color diffracting and dispersing the incident light [21-22]. Furthermore, the glaze thickness for the analysed samples ranges from 80 μm to 250 μm . According to SEM examinations, it can be suggested that Zamoran potters used a two-firing technique for crafting their potteries. This fact is further supported by the existence of a very thin reaction area in the interface between glaze and clay body, which shows low crystallization in all the ceramics (Figure 13.1). According to literature [23-24], the features shown by these ceramics is compatible with a double firing process for lead and tin-lead glazed and calcareous illitic pastes. Furthermore, it is documented in historical written sources that a double firing technique was commonly employed by majolica potters in modern era Spanish productions [2]. Besides, biscuit and failure ceramic evidences have been unearthed in the Olivares workshop kiln dumps, reinforcing the idea of a double firing process conducted in Zamora productions [8,10].

Regarding the blue decoration, this one was achieved by the use of Co and Fe. Surprisingly, 5 μm particles can be easily detected by backscattering electron configuration, and even reaching up to 15 μm in two dimensional size (Figure 13.2). Interestingly, in the blue areas of the Zamoran ceramics, Co-Fe particles are found under the glaze and directly in contact with the clay body. Unexpectedly, this blue under coating decoration has been identified for the first time in this area and, up to the knowledge of the authors, it is also the first time this technological choice is documented in northern Spain. However, this undercoating decoration technique has few parallels in other areas of Spain, mainly in Valencia region [25]. Besides, a K and P enriched layer related to these Co-Fe particulates has been also detected far below from the glaze outer part. Therefore, a plausible hypothesis is that this layer might be in relation to the use of an agglutinant in the application of the blue pigment over the biscuit ceramic body.

Green decorations follow traditional hispanomoresque recipes for green color achievement. Thus, Cu content has been found dispersed in green areas by SEM-EDS, which enables to think that the responsible for green pigment is a Cu compound (Figure 13.3). The fact that Sn also appears in the same region than green decoration enables to think that Cu compound is applied on the white glaze in order to get green, in agreement with previous studies for the main postmedieval production centers of Spain [2, 22].

Finally, both, brown and black pigments have been also identified by SEM-EDS. Remarkably, Mn compounds are unequivocally the responsible for obtaining these colors. Moreover, by backscattering electron imaging, Mn particles are clearly highlighted on the upper regions of the brown/black glazes (Figure 13.4). Thus, the size of these Mn particles range from a few micrometers up to 30 μm , and can be found as mainly Mn particles or as Mn-Si-Pb particles (lighter in color in Figure 13.4).

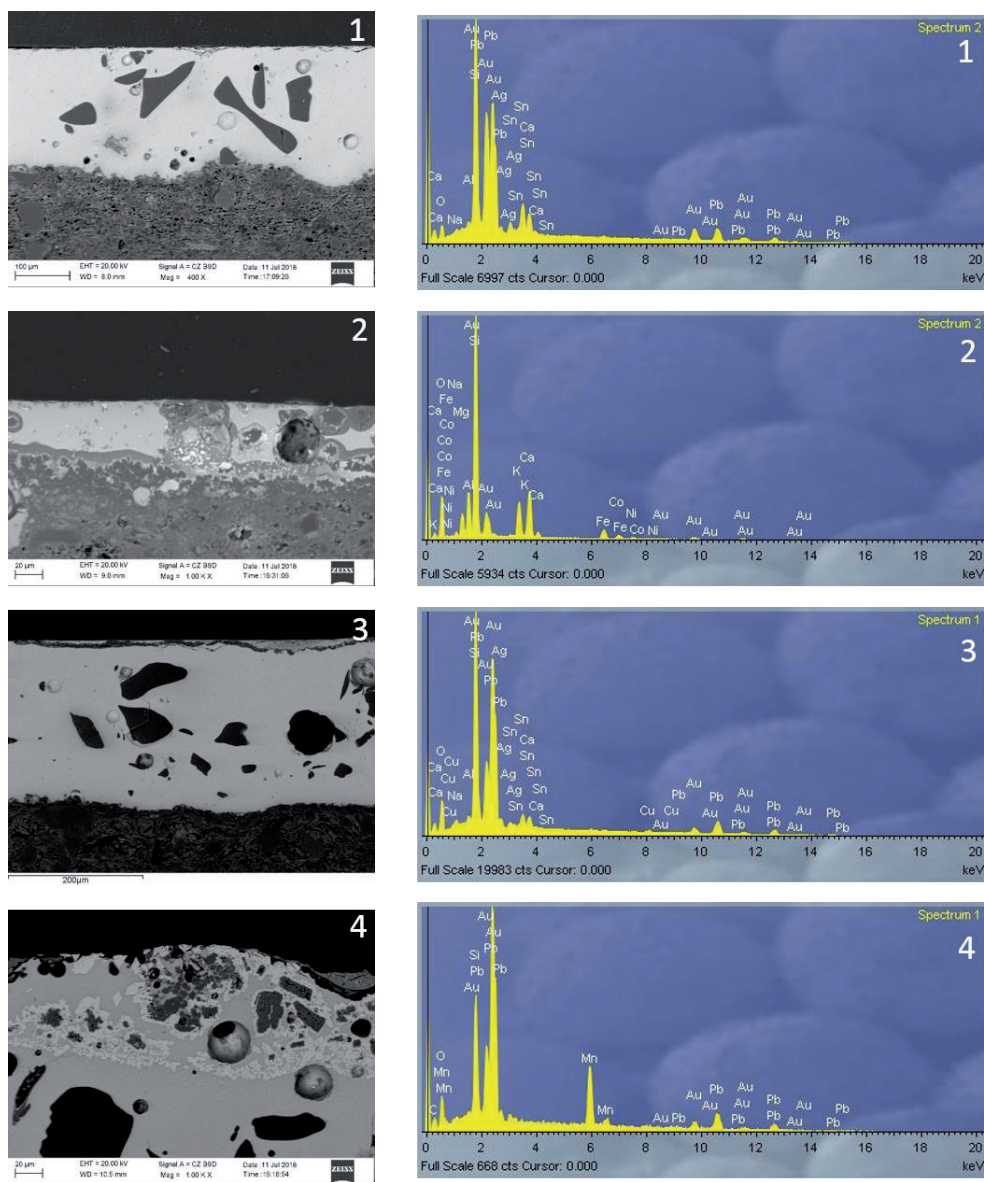


Figure 13: SEM-EDS results of the glazed ceramics. Image 1 shows Sn particles distributed thoroughly within the glaze, giving the white color. Image 2 shows Co and Fe, the responsible for the blue color. Image 3 shows Cu, the responsible for the green color; Image 4 shows Mn, the responsible for brown or black color.

CONCLUSION

This study has deepened into the understanding of the pottery consumption in Zamora during Late Medieval and Early Modern periods after the archaeometrical characterization of pottery unearthed in the Church of La Concepción. Thus, chemical analysis has enabled the identification of two reference groups. Along these lines, tin-lead glazed pottery from this site is chemically

compatible with the already established Z-3 local reference group from the Olivares workshop in the outskirts of the city of Zamora. Furthermore, one new chemical group has been identified: Z-4. This group is formed uniquely by micaceous unglazed ceramics, although its local origin cannot be surely proposed given the state of archaeometrical knowledge up to date. Then, a regional Zamoran provenance should be highly taken into consideration as well. Unfortunately, two micaceous ceramics could not be assigned to any of the known chemical reference groups. In addition, one ceramic archaeologically described as *Duque de la Victoria* type from Valladolid, could not be either assigned to the known groups, so its provenance remains unclear. Moreover, the provenance identification for the two ceramics that possible are from Pereruela or Muelas del Pan needs of further examination and of the comparison with solid reference groups for such productions.

Technologically, tin-lead glazed ceramics from Zamora at this chronological period are calcareous and show creamy color pastes, being fired at temperatures ranging from 850 °C to 1000 °C in oxidizing conditions. Additionally, most of the micaceous ceramics show a relatively low firing temperature, from 800 °C to 850 °C, while just one example reaches an EFT of 900 °C.

Besides, SEM-EDS analyses have facilitated the identification of the nature of the different pigments employed by Zamoran potters for decorating their ceramics following traditional hispanomoresque contemporary recipes. Thus, white opaque coatings were achieved by the use of SnO₂ in the Si-Pb glaze. Moreover, green color is obtained by the addition of Cu compounds, while the brown/black pigment is obtained by the use of Mn ones. Interestingly, the nature of blue pigment is related to the use of Co and Fe particles, which seem to be applied under the glaze coating.

In agreement with the archaeometrical results of this study, the consumption of pottery by the people who inhabited and work in the goldsmithing workshop during the 15th and early 16th centuries show a local pattern. In this way, the use of local Zamoran ceramics, as well as micaceous ceramics from regional contexts, is predominant in this site. Therefore, and given the initial results presented, a long-distance trade cannot be excluded, although it is not reinforced by the archaeometrical results of the sample studied so far.

Acknowledgements

The ongoing investigation is framed in the research project *Archaeology and Archaeometry of the ceramic production and distribution in the Central-Northern Iberian Peninsula from the 16th to the 18th century* funded by the Spanish Ministry of Economy, Industry and Competitiveness CERANOR-2 (HAR2017-84219-P). USG thanks the University of the Basque Country (UPV/EHU) for doctoral grant *Hiring for Research Training* (PIF2017/153). JGI thanks the Spanish Ministry of Economy and Competitiveness for a Ramon y Cajal contract (RYC-2014-16835). The authors wish to thank *Museo de Zamora* for providing the sample material. We would like to thank *Coupled Multispectroscopy Singular Laboratory* (LASPEA) from the *Advanced Research Facilities* (SGIker) of The University of the Basque Country UPV/EHU for SEM-EDS analysis. The authors also acknowledge *The General X-ray Service* from SGIker of the University of the Basque Country UPV/EHU as well as technical and human support provided by the *SGIker-Geochronology and Isotope Geochemistry Facility* (UPV/EHU, MICINN, GV/EJ, ERDF and ESF).

Bibliographic references

¹ CERDÀ, Josep Antoni – *La ceràmica catalana del segle XVII trobada a la plaça Gran (Mataró)*. Associació Catalana de Ceràmica, Barcelona, 2001.

- ² IÑÁÑEZ, Javier – *Caracterització arqueomètrica de la ceràmica vidrada decorada de la Baixa Edat Mitjana al Renaixement dels principals centres productors de la Península Ibèrica*. Tesis Doctorals en Xarxa, Barcelona, 2007
- ³ VILLANUEVA ZUBIZARRETA, Olatz – “La Ollería y alcajería en la cuenca del Duero a lo largo de la Edad Media y Moderna”, in: *Manual de Cerámica Medieval y Moderna*, Museo Arqueológico Regional, Madrid, February 2011.
- ⁴ LARRÉN IZQUIERDO, Hortensia – *Fondos cerámicos marcados procedentes de Zamora*. Boletín de Arqueología Medieval, 5, 1991, 167-179.
- ⁵ MARTÍN CARBAJO, Miguel Ángel; VILLANUEVA MARTÍN, Luis Alberto; SANZ GARCÍA, Francisco Javier; MARCOS CONTRERAS, Gregorio José; MISIEGO TEJEDA, Jesús Carlos; GARCÍA MARTÍNEZ, María Isabel; DEL CAÑO GARCÍA, Luis Ángel – *Trabajos arqueológicos en el solar del antiguo Convento de La Concepción, en Zamora*. Anuario 2002 del Instituto de Estudios Zamoranos “Florián de Ocampo”, 19, 2002, 115-139.
- ⁶ MARTÍN CARBAJO, Miguel Ángel; SANZ GARCÍA, Francisco Javier; MISIEGO TEJEDA, Jesús Carlos; MARCOS CONTRERAS, Gregorio José; VILLANUEVA MARTÍN, Luis Alberto; FERNÁNDEZ ORALLO, Emilia; GARCÍA MARTÍNEZ, María Isabel; GARCÍA RIVERO, Pedro Francisco – “Las excavaciones arqueológicas en la Iglesia y el Convento de La Concepción”, in: *389 años del Convento de La Concepción*, Junta de Castilla y León, Consejería de Educación y Cultura, Zamora, 2003.
- ⁷ VILLANUEVA MARTÍN, Luis Alberto; MARTÍN CARBAJO, Miguel Ángel; MARCOS CONTRERAS, Gregorio José; SANZ GARCÍA, Francisco Javier; MISIEGO TEJEDA, Jesús Carlos; FERNÁNDEZ ORALLO, Emilia – *Un taller de orfebrería de Época Bajomedieval y Moderna, bajo los restos de la Iglesia y Convento de Nuestra Señora de La Concepción, de Zamora*. Anuario 2000 del Instituto de Estudios Zamoranos “Florián de Ocampo”, 17, 2000, 79-112.
- ⁸ SANZ GARCÍA, Francisco Javier; MISIEGO TEJEDA, Jesús Carlos; MARCOS CONTRERAS, Gregorio José; MARTÍN CARBAJO, Miguel Ángel; FERNÁNDEZ ORALLO, Emilia; GARCÍA MARTÍNEZ, María Isabel – *La actividad artesanal en el barrio de Olivares de Zamora. Los Hallazgos en el solar de la Plaza de San Claudio, 6 c/v a la Calle Mediodía, 2*. Anuario 2005 del Instituto de Estudios Zamoranos “Florián de Ocampo”, 22, 2005, 229-240.
- ⁹ BUXEDA I GARRIGÓS, Jaume; CAU ONTIVEROS, Miguel Ángel; KILIKOGLU, Vassilis – *Chemical variability in clays and pottery from a traditional cooking pot production village: testing assumptions in Pereruela*. Archaeometry, 45, 2003, 1-17.
- ¹⁰ IÑÁÑEZ, Javier; SANCHEZ GARMENDIA, Uxue; CALPARSORO FORCADA, Estefania; ARANA MOMOITIO, Gorka – *Zamora and the pottery from Olivares workshops: long-tradition pottery manufacturing in the heart of Spain*. In: 42nd International Symposium on Archaeometry ISA 2018, Ruvalcaba, José Luís, Mexico, 2018, 166.
- ¹¹ BUXEDA I GARRIGÓS, Jaume; CAU ONTIVEROS, Miguel Ángel – *Identificación y significado de la calcita secundaria en cerámicas arqueológicas*. Complutum, 6, 1995, 293-309.
- ¹² GARCÍA DE MADINABEITIA, Sonia; SÁNCHEZ LORDA, Maria Eugenia; GIL IBARGUCHI, José Ignacio – *Simultaneous determination of major to ultratrace elements in geological samples by fusion-dissolution and inductively coupled plasma mass spectrometry techniques*. Analytica Chimica Acta, 625, 2008, 117-130.
- ¹³ AITCHISON, John – *The single principle of compositional data analysis, continuing fallacies, confusions and misunderstandings and some suggested remedies*. CoDaWork, Girona, 2008, 1-28.

- ¹⁴ AITCHISON, John – *The Statistical Analysis of Compositional Data*. Journal of the Royal Statistical Society B, 44, 1982, 139-177.
- ¹⁵ BUXEDA I GARRIGÓS, Jaume – *Alteration and Contamination of Archaeological Ceramics: The Perturbation Problem*. Journal of Archaeological Science, 26, 1999, 295-313.
- ¹⁶ BUXEDA I GARRIGÓS, Jaume; KILIKOGLU, Vassilis – “Total variation as a measure of variability in chemical data sets”. In: VAN ZELST, L. (Ed.), *Patterns and process. A Festschrift in Honor of Dr. Edward V. Sayre*. Smithsonian Center for Materials Research and Education, Suitland, Maryland, 2003, 185–198.
- ¹⁷ WEIGAND, Phil C.; HARBOTTLE, Garman; SAYRE, Edward V. – “Turquoise sources and source analysis: Mesoamerica and the southwestern U.S.A.”, in: EARLE, T.K. and ERICSON, J.E. (Eds.), *Exchange Systems in Prehistory*. Academic Press, New York, NY, 1977, 15–34
- ¹⁸ LEMOINE, Charlotte; PICON, Maurice – *La fixation du phosphore par les céramiques lors de leur enfouissements et ses incidences analytiques*. Revue d’achéométrie, 6, 1982, 101-112.
- ¹⁹ PRADELL, Trinitat; VENDRELL-SAZ, Marius; KRUMBEIN, Wolfgang E; PICON, Maurice – *Altérations de céramiques en milieu marin : les amphores de l’épave romaine de la Madrague de Giens (Var)*. Revue d’achéométrie, 20, 1996, 47-56.
- ²⁰ MOLERA, Judit; PRADELL, Trinitat; VENDRELL, Marius – *The colours of Ca-rich ceramic pastes: origin and characterization*. Applied Clay Science, 13, 1998, 187-202.
- ²¹ MOLERA, Judit; PRADELL, Trinitat; SALVADÓ, Nati; VENDRELL SAZ, Marius – *Evidence of tin oxide recrystallization in opacified lead glazes*. Journal of the American Ceramic Society, 82, 1999, 2871-2875.
- ²² IÑÁÑEZ, Javier; MADRID I FERNÁNDEZ, Marisol; MOLERA, Judit; SPEAKMAN, Robert J.; PRADELL, Trinitat. *Potters and Pigments: preliminary technological assessment of pigment recipes of American majolica by Synchrotron Radiation micro-X-ray Diffraction (SR- μ XRD)*. Journal of Archaeological Science, 40, 2013, 1408 - 1415
- ²³ MOLERA, Judit; PRADELL, Trinitat; MARTÍNEZ MANENT, Salvador, VENDRELL SAZ, Marius – *The growth of sanidine crystals in the lead of glazes of Hispano-Moresque pottery*. Applied Clay Science, 7, 1993, 483-491.
- ²⁴ MOLERA, Judit; PRADELL, Trinitat; SALVADÓ, Nati; VENDRELL SAZ, Marius – *Interactions between Clay Bodies and Lead Glazes*. Journal of the American Ceramic Society, 84, 2001, 1120-1128.
- ²⁵ CASTRO, Elvira A; DOMÉNECH CARBÓ, María Teresa – “Aproximación al examen científico de la cerámica medieval de manises. Caracterización mineralógica mediante microscopía electrónica y difracción de rayos X”, in: *Spanish Medieval Ceramics in Spain and the British Isles*, BAR International Series, Archaeopress, Oxford, 1995.

Villafeliche, an 18th century majolica producing village in the heart of Aragon (Spain)

Javier G. Iñáñez

University of the Basque Country (UPV/EHU), Centro de Investigación. Micaela Portilla, C/ Justo Vélez de Elorriaga, 1, Vitoria-Gasteiz, Spain, javier.inanez@ehu.eus

SUMMARY: In order to shed light to the ceramic productions from Villafeliche, a sample of 21 ceramics obtained from the Museu de la Ceràmica de Barcelona collection was analyzed. All the ceramics analyzed were tin lead glazed pottery with blue on white motifs and dated back to the 18th century. These ceramics were unearthed in the context of the archaeological surveys conducted in the ceramic dumps of Villafeliche, specifically in the workshop area known as “Los Portillos”. The archaeometrical results carried out by XRF, XRD and SEM-EDS enable linking the ceramics unearthed in Villafeliche to a local origin related to the ceramic productions during the 18th centuries, in agreement with the archaeological record. Thus, the production of the 18th century keeps the tradition of employing calcareous clays that is observed in previous local productions, as well as the use of tin lead glaze recipes for glazed coatings.

KEY-WORDS: Spain, tin lead glaze, chemical analysis, XRD, SEM-EDS

INTRODUCTION

Tin-lead glazed pottery, also known as Majolica, is earthenware pottery characterized by a creamy light-buff colored ceramic body and an opaque white tin-lead glaze covering the entire outer surface of the vessel. The most characteristic feature of majolica pottery lies in the metallic-oxide decorations that are applied on top of the opaque white glaze coat. The opaque white glaze is composed of sand (e.g., quartz) and lead, which serves as a flux to decrease the temperature needed for melting SiO₂. Opacity is usually achieved by means of tin oxide (SnO₂) crystals and by the action of extant quartz and feldspar inclusions. These inclusions, and the bubbles that result from the firing process, absorb, scatter, and/or reflect incident light, thereby giving the transparent glaze a white appearance. Due to this opacity, decoration is usually applied to the outer surfaces of the glaze coat¹⁻⁴.

By the sixteenth century, Spanish majolica production flourished as Italian-influenced decorative styles diffused into the Iberian Peninsula. Aragonese majolica also was influenced by the new Italian-influenced decorative trends and styles. Consequently, black and especially green motifs—colors associated with Islamic ceramic traditions—were progressively replaced by blue patterns, sometimes mixed with other colors, such as yellow. In contrast, however, Aragonese potters combined traditional hispanomoresque motifs, with the new Renaissance influences. This fusion of decorative elements resulted in a distinctive ceramic product. From the sixteenth century until the end of the eighteenth century, the town of Muel and Villafeliche afterwards, became the main production centers in the region of Aragon along with Teruel. Although lusterware production was very important during fifteenth and sixteenth centuries in Muel, tin lead glazed pottery decorated with blue on white motifs made in Muel and Villafeliche achieved a relevant impact on Renaissance Spain⁵.

The production of tin lead glazed ceramic in Villafeliche can be chronologically established during the 15th century, and strongly linked to the hispanomoresque population. Villafeliche,

along with Muel and Teruel, is one of the main majolica production centers of the Iberian Peninsula. The technical and artistical quality achieved by the ceramists from Villafeliche provided the village with wide recognition, especially regarding the blue and polychrome tin lead glazed ceramics.

According to historical written records, the village of Villafeliche belonged to the Camarassa marquis, who expanded the city walled limits with the establishment of new workshops in early Modern era. These new artisan areas received the name of *Herrerias* (blacksmiths) and *Ollerias* (pottery workshops) neighborhoods, amongst others⁶. In this way, in a document dated to 1575, a potter appears in a wedding contract, evidencing the ceramic activity in Villafeliche. Furthermore, the Camarassa marquis rented some properties to a neighbor from the nearby Monton village, providing historians with a very detailed description of the neighborhoods and main work activities in Villafeliche, including pottery making. Interestingly, this demonstrates that the pottery workshops and ceramic activity in Villafeliche was kept intact even after the expulsion of the Moresque population in 1609-1614, which was Muslim population converted into Christians by law, although most of them managed to keep some of their cultural and religious idiosyncrasy⁶. In addition, new potters were established into the village, according to written documents. Along these lines, names like “Jaime Villar, *cantarero* (jar making)” in 1623, or Pablo Pasqual, *escudiller* (porringer maker) in 1626, appear as doing transactions with traders or as house owners⁶. Besides, the ceramic activity of the village is clearly linked to the production of black powder, which both showed a growing pulse since late 17th century and during the whole 18th century. However, in the 19th century, tin lead glazed production seems to clearly decreasing and, already at the beginning of the 20th century, it has completely ceased.

Workshops in Villafeliche occupied wide areas in the outskirts of the village. Thus, several locations can be identified according to different chronologies and ceramic functionality, like tin lead glazed producers or cooking ware producers. The Moresque workshops were, likely, located in the *Campo del Toro* area (nowadays *Plaza Mayor*), where many kiln materials and ceramic failures were discovered in two sectors known as *Los Cascos* (name that can be translated as broken ceramics) and “*Los Portillos*. This area was geographically and socially opposed to the old town, where the so-called old Christians were established. In addition, and according to the local toponomy, there were several workshop areas active in the village from 17th century onwards. In this way, up to five different workshop points can be identified for that chronology in Villafeliche according to the ceramic material discarded dumps: in addition to the two workshops already mentioned of *Los Cascos* (1) and *Los Portillos* (2), there were the workshops from the *Camino de los Hornos* (which can be translated as the road to the kilns) (3), the workshops from Old Quarter and *Tejeria* (the tile workshop) (4), as well as the ones from the road to Montón (5)⁶.

From an archaeometrical point of view, and despite the fact that many significant works concerning majolica pottery technology have been published, with especial incidence for the study of lusterware (for instance, see ⁷⁻⁹), archaeometric knowledge about tin-lead glazed pottery produced in the Iberian Peninsula is uneven. Consequently, there was an overall lack of chemically defined reference groups that characterize the primary production centers. Fortunately, this shortage has been palliated at some extend regarding the postmedieval production centers of Spain, mainly, such as Paterna, Manises, Barcelona, Lleida, Reus and Vilafranca del Penedès, Talavera, Puente del Arzobispo, Seville, Zamora, and Orduña. In addition, a few studies have examined the occurrence of Spanish majolica at overseas sites like the Canary Islands and the Americas in the frame of the colonial market, most of which refer to production in Seville (for a more comprehensive state of the art no the subject, see ¹⁰⁻¹¹).



Figure 1: Location of Villafeliche

Regarding the study of Aragonese tin lead glazed pottery, and although many works have sought to deepen the knowledge, description, and understanding of Medieval and Renaissance Aragonese ceramic productions, most of the studies have been undertaken from the point of view of the Art History or Archaeology. Unfortunately, archaeometrical studies based on the provenance or technological features of the Aragonese ceramics are relatively scarce but include thin section petrography¹² and chemical characterization of the paste and glazes^{1-2, 13-18}, mainly from Teruel and Muel workshops. Consequently, the present knowledge about tin-lead glazed pottery from Aragon workshops remains uneven and limited at some extent and, especially, regarding the postmedieval productions of Villafeliche.

SAMPLES AND GOAL

In order to shed light to the ceramic productions from Villafeliche, a sample of 21 ceramics obtained from the Museu de la Ceràmica de Barcelona collection was obtained. All the ceramics analyzed were tin lead glazed pottery with blue on white motifs and dated back to the 18th century. These ceramics were unearthed in the context of the archaeological surveys conducted by Llubia during the mid-20th century in the ceramic dumps of Villafeliche, specifically in the workshop area known as *Los Portillos*. Thus, the ceramics that compose this study are considered of local origin given its attribution to a ceramic dump and the fact that the sample also includes kiln furniture, such as spurs, as well as discarded ceramics or failures (Figure 2). In this paper, we summarize the results from archaeometrical characterization of 21 majolica sherds from the workshops of Villafeliche and their comparison with the main production centers from medieval and postmedieval Spain.



Figure 2: Example of the ceramics from Villafeliche

METHODOLOGY

All of the 21 specimens were sampled from extant collection of the *Museu de la Ceràmica* in Barcelona, a repository that has large reference collections for most of the primary majolica production sites in Spain after archaeological works of these workshops conducted in the 1950's and 1960's. Our sampling strategy was strictly focused on kiln-related materials to maximize the probability that the materials included in this study were a product of their respective workshops and production centers. In that way, we focused on ceramics from archaeologically and historically documented majolica kiln dumps.

In the present study, twelve grams from each sherd were taken and glazes and other surfaces were mechanically removed to minimize contamination from glaze and soil. Following this process, specimens were powdered and homogenized in a Spex Mixer (Mod. 8000) tungsten carbide cell mill for 12 minutes. Powdered specimens were stored in clean polyethylene vials for transportation to the laboratory.

The chemical compositions of the samples analyzed by XRF were determined using a Phillips PW 2400 spectrometer with Rh excitation source. Samples were prepared for analysis using two different methods. Duplicates of glassy pills made by fusing 0.3 g of dry powder with 5.7 g of LiBO_4 to determine the major and minor elements with the exception of Na_2O . Trace elements and Na_2O were determined from 5 g pills of powdered dry sample. The quantification of the concentrations was obtained using a calibration line based on 60 international geological standards. The elements determined were Fe_2O_3 (as total Fe), Al_2O_3 , MnO, P_2O_5 , TiO_2 , MgO, CaO, Na_2O , K_2O , SiO_2 , Ba, Rb, Mo, Th, Nb, Pb, Zr, Y, Sr, Sn, Ce, Co, Ga, V, Zn, W, Cu and Ni. The loss on ignition (LOI) was determined by firing 0.3 g of dried powder at 950°C for 3 h. An extended description of the XRF analytical procedures, including the details of accuracy and precision, has been published elsewhere¹⁹.

The mineralogical composition of all the samples included in the study was determined by XRD, using the same powdered sample prepared for XRF analysis. Measurements were performed using a PANalytical X'Pert PRO alpha1 powder diffractometer (radius = 240 mm) using the $\text{Cu K}\alpha$ radiation ($\lambda = 1.5418 \text{ \AA}$), with a working power of 45 kV – 40 mA. The incident beam was

passed through a 0.04 radians Soller slit, and the diffracted beam was passed through another one. Moreover, the diffracted beam was Ni filtered. An X'Celerator Detector, with active length = 2.122 °, was used. $\theta/2\theta$ scans were recorded from 4 to 70 ° 2θ (step size=0.017°; time=50 s per step). The evaluation of crystalline phases was carried out using the DIFFRACT/AT program by Siemens, which includes the Joint Committee of Powder Diffraction Standards (JCPDS) data bank.

The SEM study was conducted on 2 glazed ceramics after being transversally cut, embeded in epoxy resin and metallographically polished. Samples were gold coated and examined under an EVO 40 Carl-Zeiss SEM coupled to an energy dispersive X-ray analyzer (EDX). Sample examination was conducted at 20 kV and a current of 500 mA under full vacuum conditions. The elemental composition of decorative coatings was determined by an electron dispersive spectrometry (EDS) analysis of areas corresponding to each color, using an X-Max (Oxford Instruments) equipment. The working distance ranged between 7.5 and 10.5 mm. The EDS spectra were acquired and treated using the INCA software (Oxford Instruments).

Statistical analysis of the data followed Aitchison's approach and Buxeda's observations on compositional data²⁰⁻²³. The D-compositional chemical data were transformed to log-ratios following Aitchison's and Buxeda's recommendations, by taking the natural logarithm of the ratio of all determined components to one component selected as divisor according to

$$\mathbf{x} \in S^d \rightarrow \mathbf{y} = \ln\left(\frac{\mathbf{x}_{-D}}{x_D}\right) \in R^d,$$

where $\mathbf{x}_{-D}=(x_1, \dots, x_d)$ ²²⁻²³. The variation matrix was used as an exploratory tool to identify sources of compositional variability, to quantify this variability, and to identify the appropriate element to be used as a divisor in the log-ratio transformation²³. Thus, statistical procedure consists of the use of ratios of natural logarithms obtained by dividing all the components, in this case the elements, by the element that introduces the lowest chemical variability to the entire set of specimens to minimize the compositional data problem referred to as "close to unit sum", when data necessarily must sum 100%. Moreover, the use of logarithms compensates for differences in magnitudes between major elements, such as Al₂O₃ and Fe₂O₃, and trace elements. Furthermore, log-transformed data serve to make the distributions of geochemical data more nearly normal. By dividing all components by the component that exhibits the lowest variability, one also overcomes relative magnitudes problems of a given subcomposition, because after logratio transformation we work with the same relative magnitudes for each specimen given that $s_i/s_j = x_i/x_j$ ²⁰⁻²¹. Finally, logratio transformations can highlight possible perturbations in the chemical data because of diagenesis, contamination, or other alteration processes²².

Moreover, Villafeliche specimens were compared against several reference groups already established for the primary productions centers on the Iberian Peninsula. To date, more than a 1500 ceramics have been chemically analyzed using multiple analytical techniques enabling to identify numerous reference groups for Barcelona, Reus, Vilafranca del Penedès, Lleida, Paterna, Manises, Muel, Teruel, Villafeliche, Talavera de la Reina, Puente del Arzobispo, Logroño, Orduña, Elosu, Zamora and Seville. All of these samples have been also mineralogically characterized by XRD and, a selection of them, by SEM-EDS.

RESULTS AND DISCUSSION

Chemical Analyses

Although sample preparation was conducted under a great care to minimize the analytical error, the potential for contamination does exist. As a precaution, W and Co were removed from

consideration during the statistical analysis of chemical data because samples were powdered using a tungsten carbide cell grinder in which W is a major component and Co is a minor component.

Additionally, the technology of majolica pottery production is characterized by Sn and high Pb concentration in their glazes, causing analytical problems because of their diffusion into the clay matrix body. Therefore, Sn and Pb concentrations have not been considered because of the possibility of contamination from the glaze. Moreover, chemical results have shown that Pb content largely exceeds the upper XRF regression limit (928 ppm). In XRF, unusually high Pb results in interferences with nearby emission peaks. Thus, trace elements such Ga and Y, and Th and Rb, might have high error. Consequently, these elements were not considered in the analysis of the XRF. Moreover, Mo, as determined by XRF, is always below the lower regression limit and cannot accurately be determined.

Conversely, since all the 21 individuals have been analyzed by X-Ray Diffraction analyses, it has been possible to observe that a relevant number of the analyzed majolica sherds (10 out of 21) exhibited a double process of alteration and contamination (Table 1, 2), also documented in previous studies^{1-3,10}. This process reports the leaching of potassium and, sometimes, rubidium, from the matrix, with a subsequent enrichment of sodium because of analcime crystallization^{1,24-25}. Therefore, these alteration and contamination processes affect those components in the matrix composition, without any possibility of calculating a satisfactory correction. As a result, Na₂O, K₂O, and Rb were also removed from consideration during the statistical analysis.

During statistical treatment, chemical variables have been transformed into logarithm ratios following the aforementioned methodologies from the following subcomposition: Fe₂O₃, Al₂O₃, MnO, TiO₂, MgO, CaO, SiO₂, Ba, Zn, Sr, Ce, V, Zn, Ni and Cr, using Nb as divisor since it is the less variable amongst the dataset, according to the calculated variation matrix²³. The variation matrix obtained shows a total variation (vt) of 0.214, which enables to suggest a monogenetic grouping²³. The elements responsible for the highest variation amongst the dataset are, mainly, MgO, CaO, Na₂O, K₂O, Sr, Ce and Cu (vt/ τ_i <0.6). Besides, MJ0068 shows a high variation due, mainly, to its very high CaO content (23.71%) (Table 1). Therefore, when calculating a new compositional variation matrix without considering those elements that are susceptible of being altered (Na₂O, K₂O and Cu), the vt is only of 0.098, which is clearly an indication of a very compact chemical group²³.

Results can be summarized in the dendrogram obtained after the clustering analysis of the latter subcomposition using the Euclidian squared distance and the centroid agglomerative method. The study of the dendrogram enables determining a single homogeneous structure showing fusions between individuals at very low ultrametric distance (<0.05 units). Dissimilarities between individuals are mainly due to slight differences in Zr, Ba and Ce, having the ceramics on the left of the dendrogram a more abundant clayey phase than the ceramics on the right of the dendrogram, which show higher Zr amounts related to more sandy phases. The individual MJ0068 merges with the rest of the ceramics at a higher ultrametric distance (0.15 units), mainly due to its higher CaO amounts (23.71%), while the mean of CaO for the Villafeliche ceramics is 17.39%. Therefore, the small differences observed between ceramics should not be due to differences in productions or recipes but most likely, to the fact that these productions are pre-industrial processes. Thus, results enable the interpretation that 18th century potters used standardized recipes but showing slight differences due to small geochemical differences within the clay pits and later processing, supported by archaeological data.

Compounds	Mean	σ	Compounds	Mean	σ
Fe₂O₃ (%)	4.45	0.17	Ba (ppm)	500	32
Al₂O₃ (%)	15.71	0.81	Nb (ppm)	17	0
MnO (%)	0.04	0	Zr (ppm)	209	13
P₂O₅ (%)	0.18	0.01	Sr (ppm)	632	62
TiO₂ (%)	0.74	0.02	Ce (ppm)	63	7
MgO (%)	2.82	0.52	V (ppm)	69	4
CaO (%)	17.39	1.07	Zn (ppm)	74	5
Na₂O (%)	0.31	0.07	Cu (ppm)	48	21
K₂O (%)	3.82	0.29	Ni (ppm)	29	2
SiO₂ (%)	54.37	0.97	Cr (ppm)	69	2

Table 1: Chemical results by XRF of major and minor elements (wt%) and trace elements (expressed as ppm or $\mu\text{g}\cdot\text{g}^{-1}$). σ stands for standard deviation.

Mineralogical analysis

Mineralogically, majolica ceramics from Villafeliche show three main different arrays of mineralogical distribution. Hence, all of the analyzed ceramics are of calcareous nature and, in agreement with the different mineralogical arrays identified after XRD examinations, the equivalent firing temperature (EFT) established ranges from 900 °C to 1100 °C.

Firstly, the fabric Fa, here represented by the ceramic MJ0074, shows a crystal association of clay minerals, like illite-muscovite type, quartz, alkaline feldspars, plagioclase, calcite, hematite, pyroxene, and gehlenite. Therefore, this mineral association enables to suggest an equivalent firing temperature between 900 °C to 950/1000°C. The presence of gehlenite and pyroxene, likely as firing mineral phases, indicates that during the original firing the temperature exceeded the 850 °C. However, the occurrence of illite-muscovite also seems to indicate that firing temperature did not go beyond the 950/1000 °C, where clay minerals like illite should had been decomposed completely. The presence of calcite might be explained as secondary calcite formed during postdepositional period or as byproduct of alteration processes of mineral phases after firing^{26, 27, 28}.

Second fabric, named Fb, is formed by only two ceramics, MJ0086 and MJ0068. This fabric shows important differences when compared to fabric Fa. Thus, Fb fabric shows a lower intensity for the quartz peaks, which may indicate that this mineral had begun to decompose due to the high temperatures. It is also important to highlight the complete absence of illite-muscovite clay minerals, which are completely decomposed at high temperatures. The presence of leucite does not enable adequately to observe whether the original alkaline feldspar has completely decomposed or not. Therefore, considering the crystallization of leucite, gehlenite and the presence of plagioclase and pyroxene, the EFT suggested should be around 1050 °C.

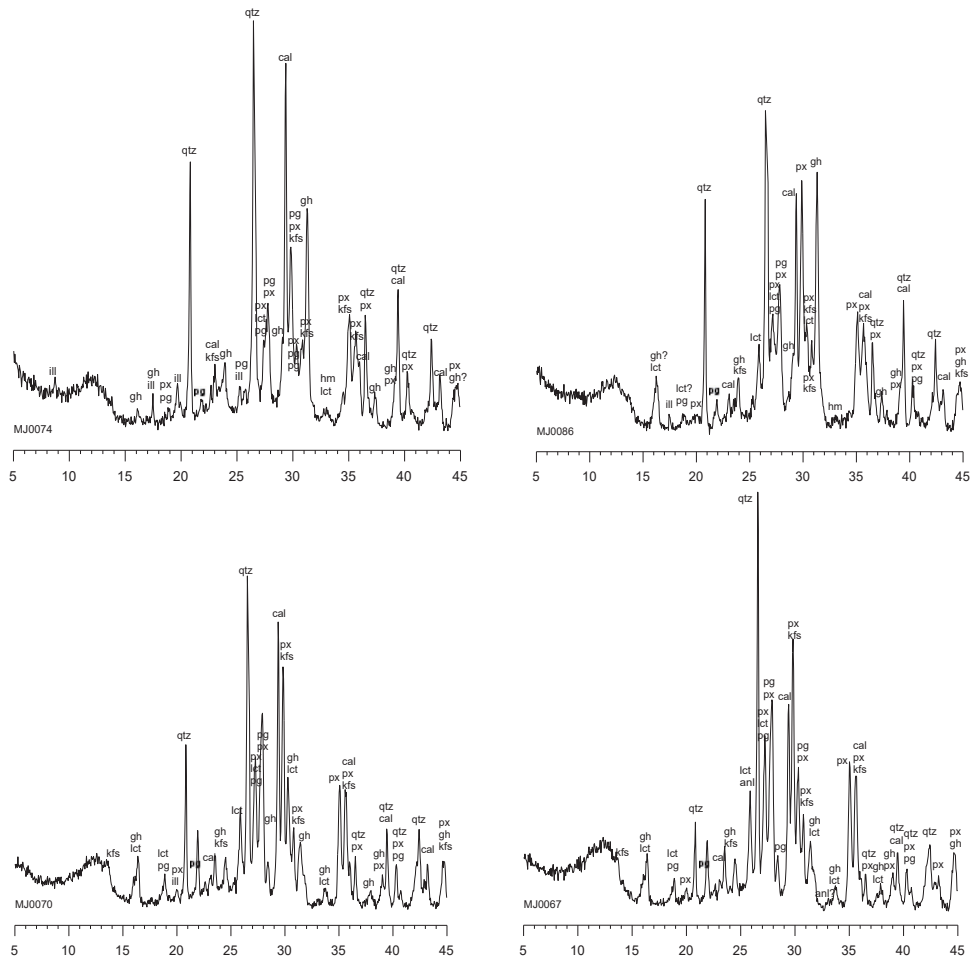


Figure 3: XRD diffractograms summarizing the four fabrics and EFT identified in Villafeliche: Fa (upper left), Fb (upper right), Fc (lower left), and Fc-anl (lower right).

Finally, a third fabric has been identified in Villafeliche. This one is made out by two subfabrics: Fc and Fc-anl. Along these lines, fabric Fc is similar to Fb, where the quartz peaks intensity have begun to decline and the practical absence of illite-muscovite. Moreover, fabric Fc, represented by individual MJ0070, shows the existence of leucite and the beginning of the decomposition process of gehlenite. These facts enable to suggest an EFT around 1010 °C. Furthermore, a group of 10 ceramics, represented by MJ0067, formed subfabric Fc-anl. This subfabric only differs from fabric Fc in the presence of analcime in their diffractograms. As has been mentioned above, the presence of analcime in ceramics has been attributed to a common alteration and contamination process that affects high-fired and overfired calcareous pottery. Such a process seems to imply a first phase of alteration of the glassy phase that leads to the leaching of potassium, followed by a second phase of analcime crystallization. The crystallization of this Na-zeolite fixes sodium from the environment into the sherd. Finally, the result can be a significant loss of potassium together with an enrichment of sodium^{1, 24-27}. Therefore, the EFT suggested for Fc-anl should range the 1050/1100 °C.

Fabric	Villafeliche	Total
Fa (900 950/1000°C)	MJ074, MJ082, MJ085	3
Fb (1050°C)	MJ086, MJ068	2
Fc (1050/1100°C)	MJ070, MJ075, MJ077, MJ080, MJ083, MJ084	6
Fc-anl (1050/1100°C)	MJ066, MJ0067, MJ069, MJ0071, MJ072, MJ073, MJ076, MJ078, MJ079, MJ081	10
Total		21

Table 2: Summary of the ceramic fabrics from Villafeliche with indication of the EFT according to the interpretation of mineral phases by XRD

GLAZE TECHNOLOGY

According to SEM-EDS results of the glazed ceramics, the glaze recipes used for making Villafeliche coatings are Pb and Si based. In addition, SEM-EDS enables for identifying Sn particles distributed thoroughly within the glaze (Figure 4). These crystallites are likely cassiterite (SnO_2). Cassiterite recrystallization help out for achieving the opaque white color when diffracting and dispersing the incident light. In addition, SEM-EDS examinations enable for distinguishing relicts mainly of quartz, which also play a similar role than cassiterite in glazes^{4,29}. As seen in the microphotographies and EDS maps (Figure 4 and 5), these quartz relicts also show evidences of important reaction rims, probably due to a high temperature reached during firing and/or to keeping high temperatures over a relatively long time. This fact is further supported by the evaluation of the interactions in the interfaces between glaze and paste body. In this way, crystal growing in the interface area is relatively high for a two-firing technique, ranging from 30 μm to 70 μm (Figure 5)³⁰. Besides, it has to be kept in mind that these ceramics come from a kiln dump, so most of them are ceramics that were discarded at that time for firing failures, showing evidences of overfired and high temperatures. Regarding the blue decoration, this one was achieved by the use of Co (Figure 4, lower), following Hispano-Moresque pottery making tradition.

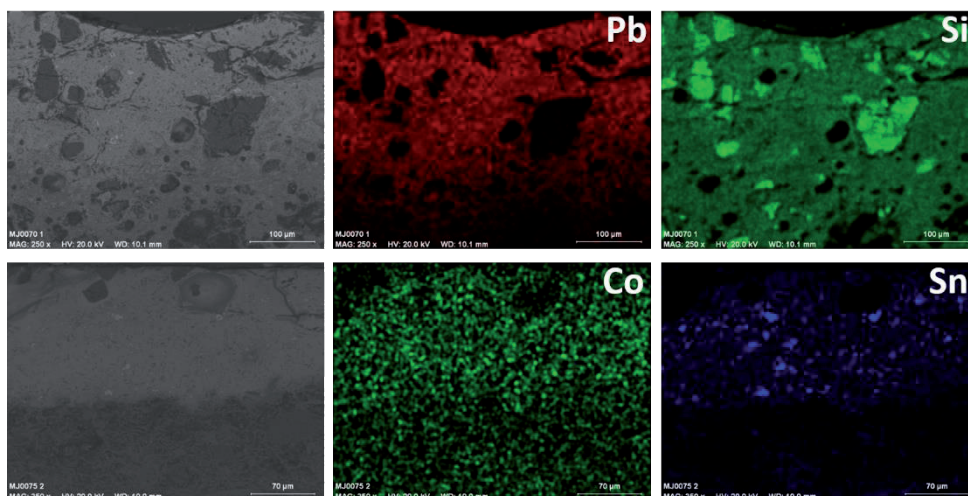


Figure 4: Elemental maps obtained by SEM-EDS (MJ0070 upper; MJ0075, lower).

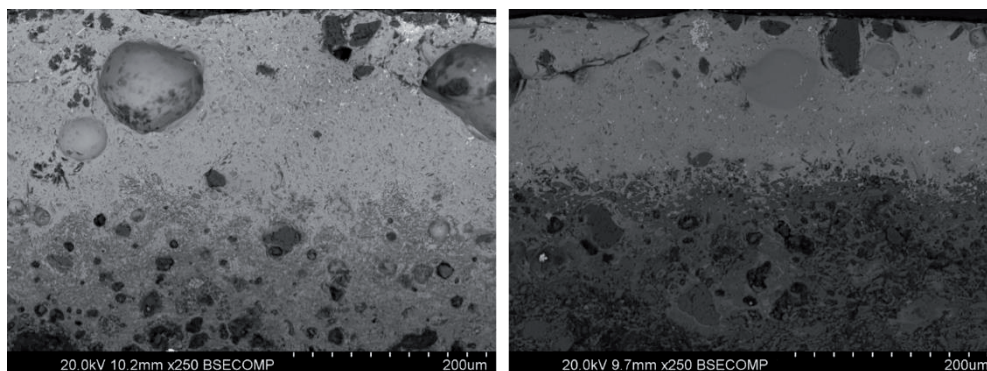


Figure 4: Microphotographs obtained by SEM using backscattered electrons (MJ0070 left; MJ0075, right).

CONCLUSIONS

The archaeometrical results enable linking the ceramics unearthed in Villafeliche to a local origin related to the ceramic productions during the 18th centuries, in agreement with the archaeological record. Thus, the production of the 18th century keeps the tradition of employing very homogenous calcareous clays that is observed in previous local productions, which is evidenced by chemical analyses. The high homogeneity of Villafeliche ceramics may respond to the role played by the potter guilds, which were the suppliers of the raw materials needed to produce ceramics by their associates (e.g. clay). In addition, these ceramics show the use of tin lead glaze recipes for their coatings. Technologically, tin lead glazed ceramics from Villafeliche at this chronological period are calcareous being fired at temperatures ranging from 900 °C to 1100 °C in oxidizing conditions.

Besides, SEM-EDS analyses have facilitated the identification of the nature of the technological choices employed by Villafeliche potters for making and decorating their ceramics following traditional Hispano-Moresque contemporary recipes. Thus, white opaque coatings were achieved by the use of SnO₂ in the Si-Pb glaze. Moreover, blue colour is obtained by the addition of Co

compounds. After SEM examination, and according to the evaluation of the interphase between clay paste and glaze, the ceramics were likely manufactured by a two-firing process technology. Thus, a first firing to obtain the bisque ceramic, desirably reaching the temperatures of 950-1000 °C as seen by XRD analysis, and a second firing for the application of the glaze, likely reaching lower temperatures in the kiln.

Acknowledgements

Author thanks the Spanish Ministry of Economy and Competitiveness for a Ramon y Cajal contract (RYC-2014-16835). The ongoing investigation in which this work is framed in the research projects funded by the Spanish Ministry of Economy, Industry and Competitiveness CERANOR-2 (HAR2017-84219-P). The XRF, SEM and XRD analyses were conducted at the Scientific-Technical Services laboratory of the University of Barcelona and at the SGIker of the UPV/EHU.

Bibliographic references

1. Iñáñez, J.G. - Caracterització arqueomètrica de la ceràmica vidrada decorada de la Baixa Edat Mitjana al Renaixement dels principals centres productors de la Península Ibèrica. 205107 TDX, Universitat de Barcelona, Barcelona, 2007
2. IÑÁÑEZ, J. G.; BUXEDA i GARRIGÓS, J.; SPEAKMAN, R. J.; GLASCOCK, M. D. - Chemical characterization of majolica from 14th-18th century production centers on the Iberian Peninsula: a preliminary neutron activation study. *Journal of Archaeological Science*, 35, pp.425–440, 2008
3. IÑÁÑEZ, J.G., BUXEDA i GARRIGÓS, J. - Pisa arcaica i ceràmica vidriada del segle XIII a Barcelona. Un estudi arqueomètric. *QUARHIS Quaderns d'Arqueologia i Història de la Ciutat*, 3, 160–179, 2007
4. MOLERA, J., PRADELL, T., SALVADO, N., VENDRELL-SAZ, M. - Evidence of tin oxide recrystallization in opacified lead glazes. *Journal of the American Ceramic Society*, 82, 2871–2875, 1999.
5. ÁLVARO-ZAMORA, M. I.: Cerámica Aragonesa. In *Cerámica española*, 221 - 288, (T. Sánchez-Pacheco, ed.), Summa Artis, Espasa Calpe, S.A., Madrid 1997.
6. ÁLVARO-ZAMORA, M.I. - Cerámica Aragonesa. Ibercaja, Zaragoza, 2003.
7. PRADELL, T. - Lustre and Nanostructures—Ancient Technologies Revisited, in: *Nanoscience and Cultural Heritage*. Atlantis Press, Paris, pp. 3–39, 2016.
8. POLVORINOS, A., AUCOUTURIER, M., BOUQUILLON, A., CASTAING, J., CAMPS, J. - The evolution of lustre ceramics from manises (valencia, spain) between the 14th and 18th centuries. *Archaeometry* 53, 490–509, 2011.
9. ROQUÉ, J., MOLERA, J., SCIAU, P., PANTOS, E., VENDRELL-SAZ, M. - Copper and silver nanocrystals in lustre lead glazes: Development and optical properties. *Journal of the European Ceramic Society*, 26, 2006..
10. IÑÁÑEZ, J.; SPEAKMAN, R. J.; BUXEDA I GARRIGÓS, J.; GLASCOCK, M. D. - Chemical characterization of tin-Lead glazed pottery from the Iberian Peninsula and the Canary Islands: initial steps toward a better understanding of Spanish colonial pottery in the Americas. *Archaeometry*, 51(4), pp. 546-567, 2009.
11. BUXEDA i GARRIGÓS, J., MADRID I FERNÁNDEZ, M., IÑÁÑEZ, J.G. - *GlobalPottery 1 : historical archaeology and archaeometry for societies in contact*. Archaeopress, Oxford, 2015.

12. GERRARD, C. M., GUTIÉRREZ, A. - El análisis de secciones delgadas y la caracterización macroscópica de algunas cerámicas medievales encontradas en Aragón, *Boletín del Museo de Zaragoza*, 7, 133 – 158, 1988.
13. PÉREZ-ARANTEGUI, J., LARREA, A. - Lustre pottery in inland Spain: analytical study of the ceramic decoration produced in Muel (Aragon) in the 16th Century. In *34th International Symposium on Archaeometry*, 531-536, (J. Pérez Arantegui, ed.), Institución Fernando el Católico (C.S.I.C), Zaragoza, 2006.
14. PÉREZ-ARANTEGUI, J., ORTEGA, J. M., ESCRICHE, C. - La tecnología de la cerámica mudéjar entre los siglos XIV y XVI: las producciones esmaltadas de las zonas de Teruel y Zaragoza. In *Avances en Arqueometría 2005. Actas del VI Congreso Ibérico de Arqueometría*, 89-96, (J. Molera, J. Farjas, P. Roura, T. Pradell, eds.), Universitat de Girona, Girona 2007.
15. PÉREZ-ARANTEGUI, J. - Colours of the Renaissance glazed pottery produced in Aragon (Spain): the cases of Teruel and Muel, *Techne*, 20, 77-82, 2004.
16. RESANO, M., PEREZ-ARANTEGUI, J., GARCIZ-RUIZ, E., VANHAECKE, F. - Laser ablation-inductively coupled plasma mass spectrometry for the fast and direct characterization of antique glazed ceramics, *Journal of Analytical Atomic Spectrometry*, 20(6), 508-514, 2005.
17. PÉREZ-ARANTEGUI, J. - Características tecnológicas de los esmaltes en la cerámica de Teruel: los primeros esmaltes. In...*operis terre Turolii*, 207 - 210, (J. Vicente Redón, ed.), Museo de Teruel, Teruel, 2002.
18. IÑÁÑEZ, J.G., SPEAKMAN, R.J., GARRIGÓS, J., GLASCOCK, M.D. - Chemical characterization of tin-lead glazed ceramics from Aragon (Spain) by neutron activation analysis. *Radiochimica Acta* 98, 525–531, 2010.
19. HEIN, A., TSOLAKIDOU, A., ILIOPOULOS, I., MOMMSEN, H., I GARRIGÓS, J., MONTANA, G., KILIKOGLU, V. - Standardisation of elemental analytical techniques applied to provenance studies of the archaeological ceramics: an inter laboratory calibration study. *Analyst* 127, 542–553, 2002.
20. AITCHISON, J. - *Statistical Analysis of Compositional Data*. Chapman & Hall, London, 1986.
21. AITCHISON, J., - The single principle of compositional data analysis, continuing fallacies, confusions and misunderstandings and some suggested remedies. *CoDaWork* 2008 1–28, 2008.
22. BUXEDA I GARRIGÓS, J., *Alteration and Contamination of Archaeological Ceramics: The Perturbation Problem*. *Journal of Archaeological Science*, 26, 295-313, 1999.
23. BUXEDA I GARRIGÓS, J.; KILIKOGLU, V. - “Total variation as a measure of variability in chemical data sets”. In: VAN ZELST, L. (Ed.), *Patterns and process. A Festschrift in Honor of Dr. Edward V. Sayre*. Smithsonian Center for Materials Research and Education, Suitland, Maryland, 185–198, 2003.
24. BUXEDA I GARRIGÓS, J., MOMMSEN, H., TSOLAKIDOU, A. - Alterations of Na, K and Rb concentrations in Mycenaean pottery and a proposed explanation using X-ray diffraction. *Archaeometry* 44, 187–198, 2002.
25. SCHWEDT, A., MOMMSEN, H., ZACHARIAS, N., BUXEDA I GARRIGÓS, J. - Alncime crystallization and compositional profiles - Comparing approaches to detect post-depositional alterations in archaeological pottery. *Archaeometry* 48, 237–251, 2006.

26. BUXEDA I GARRIGÓS, J., ONTIVEROS CAU, M.A. - Identificación y significado de la calcita secundaria en cerámicas arqueológicas. *Complutum* 6, 293–309, 1995.
27. CAU ONTIVEROS, M.A., MONTANA, G. - Secondary calcite in archaeological ceramics: evaluation of alteration and contamination processes by thin section study, in: Kilikoglou, V., Hein, A., Maniatis, Y. (Eds.), *Modern Trends in Ancient Ceramics*. British Archaeological Reports, Athens, pp. 9–18, 2002.
28. FABBRI, B., GUALTIERI, S., SHOVAL, S. - The presence of calcite in archeological ceramics. *Journal of the European Ceramic Society*, 2014.
29. IÑAÑEZ, J.G., MADRID-FERNÁNDEZ, M., MOLERA, J., SPEAKMAN, R.J., PRADELL, T. - Potters and pigments: Preliminary technological assessment of pigment recipes of American majolica by synchrotron radiation micro-X-ray diffraction (Sr- μ XRD). *Journal of Archaeological Science* 40, 1408–1415, 2013.
30. MOLERA, J., PRADELL, T., SALVADO, N. - Interactions between clay bodies and lead glazes. *Journal of the American Ceramic Society*, 84(5), pp.1120–1128, 2001.

SEM-EDS research on mineral inclusions found in the biscuit of azulejos as a tool for provenance studies

João Manuel Mimoso

Laboratório Nacional de Engenharia Civil, Lisboa- Portugal, jmimoso@lnec.pt

Dória Rodrigues Costa

Laboratório Nacional de Engenharia Civil, Lisboa- Portugal

Maria Augusta Antunes

Laboratório Nacional de Engenharia Civil, Lisboa- Portugal

Ana Margarida Cardoso

Laboratório HERCULES- Universidade de Évora, Évora- Portugal

Lurdes Esteves

Museu Nacional do Azulejo, Lisboa- Portugal

José Mirão

Laboratório HERCULES- Universidade de Évora, Évora- Portugal

Alexandre Pais

Museu Nacional do Azulejo, Lisboa- Portugal

SUMMARY: Since 2016, the Museu Nacional do Azulejo (Portuguese National Azulejo Museum), the Laboratório Nacional de Engenharia Civil and the HERCULES Laboratory of the University of Evora made a joint effort in the instrumental study of 16th century Portuguese azulejos, aimed at establishing their origin, technology and eventual systematization of workshop productions. The microscopic observation of the biscuits did not hint obviously to widespread mixtures of clays, as are routinely observed in the sections of 17th century azulejos. Therefore, it seems likely that the workshops often used plain marls with a suitable composition to grant compatibility of the biscuit with the glaze and thus their composition is a prime choice to confirm a local provenance. Azulejo samples are collected from panels on the walls and consequently are necessarily superficial and very small. In such samples the biscuit composition as pertains to minor and trace elements is tainted by the penetration of the raw glaze and digestion phenomena over firing. However inclusions of minerals that are infusible at the kiln temperatures remain largely unaltered. A means to discriminate provenance of azulejos based on a morphologic and compositional study of the small inclusions found in biscuit sections, often less than 5µm across, is proposed in this communication. These include mineral inclusions, both with and without repetitive morphologies, and micro-fossils.

This communication reviews the inclusions repetitively found in Portuguese 16th century azulejos as a first step for the construction of a database aimed at exploring their potential as markers of provenance.

RESUMO: Desde 2016, o Museu Nacional do Azulejo, o Laboratório Nacional de Engenharia Civil e o Laboratório HERCULES da Universidade de Évora, num esforço concertado, associaram-se no estudo instrumental de azulejos portugueses do século XVI, procurando estabelecer a sua origem, tecnologia empregue e uma eventual sistematização das olarias envolvidas. A observação microscópica das chacotas não revelou indícios de misturas recorrentes de barros, como é usual observar-se em secções de azulejos do século XVII. Assim, parece provável que as oficinas tenham em geral usado margas cuja composição permitia naturalmente a compatibilidade entre o biscoito e o vidrado, pelo que as suas composições são

uma escolha óbvia para confirmar proveniências locais. Muitos dos provetes utilizados no estudo foram amostradas de painéis completos ou ainda in situ e tiveram que ser, necessariamente, superficiais e de pequena dimensão. Nas secções que resultam da preparação destas pequenas escamas a composição da fracção de chacota presente, tal como a da pequena área de vidro, estão contaminadas pela interacção entre os dois materiais durante o processo de cozedura o que complica a utilização de elementos de muito baixo teor como indicadores de proveniência. No entanto e na generalidade, inclusões de minerais infusíveis à temperatura de cozedura permanecem inalteradas. Assim, é proposto um método de discriminar proveniências baseado na morfologia e composição de pequenas inclusões encontradas em secções da chacota, frequentemente de dimensões inferiores a 5µm. Estas incluem inclusões minerais, com morfologias que podem ou não ser repetitivas, e microfósseis.

Esta comunicação enumera inclusões encontradas repetitivamente em azulejos portugueses do século XVI como um primeiro passo para a construção de uma base de dados, destinada a explorar o seu potencial como elementos marcadores de proveniência.

KEY-WORDS: Provenance of ceramics; Early azulejo production in Lisbon; Use of SEM-EDS in the study of majolica; mineral inclusions in ceramics.

INTRODUCTION

16th century azulejos extant in Lisbon were locally manufactured or imported from Spain (Seville is a well-established origin [1]), from Antwerp [2] or from unknown production centres in Italy [1]. Later Portuguese azulejos (from the 17th century onwards) are easily identified on stylistic grounds but in the 16th century the first Portuguese workshops followed the Renaissance taste in patterns and designs and any attribution on that base alone is debatable. Setting aside the technological specificities of workshops that may, or may not, be present, provenance studies should best rely on those raw materials that were certainly of a local origin, in this case the sand used for the glaze and the clays or marl used for the biscuits of which there was ample supply in the Lisbon area.

Analytical studies of the glaze as a marker of geographical provenance stumble upon two main problems: on one side, the glaze incorporates several other raw materials of certainly different provenance (lead and tin compounds) or of unknown origin (e.g. the ashes used as a source of potassium or sodium oxides); and on the other side there is the often neglected fact that the glaze digests the biscuit over firing, incorporating many elements that did not previously exist or else were only residual, as Molera et al. have conclusively demonstrated [3] and the interface seen in figure 4 clearly documents. Therefore, we are left with the biscuit as a presumably best option where to find markers of geographical provenance. These can be found in the chemical composition and in the petrography of the ceramic material. A problem that is specific to azulejos, particularly renaissance productions, is that they are rare and have to be sampled from the walls which they line with the utmost prudence. Such samples include a section of glaze and a small piece of adherent biscuit, often less than 1 mm deep, collected with great care preferably from areas where the glaze is already detaching. Our (as yet unpublished) analytical results from those specks of biscuit in over 30 samples of 16th century azulejos of Portuguese origin have always returned contents in lead of up to 8% in weight (confirming Coentro's results measured on larger specimens [4]), meaning that the components of the glaze enter the biscuit and therefore

provenance studies should better concentrate on major components and not trace elements that could have been acquired from the glaze.

There is however another source of potential information on provenance residing in the biscuits: the morphology and composition of the small inclusions found there. These include mineral inclusions, both with and without repetitive morphologies, and microfossil vestiges. Microfossils and petrography in general have already been proposed by several authors in studies of provenance of clays and ceramics (e.g. [5, 6, 7, 8]). We are not aware of any previous work pointing to minerals of rare earth and heavy elements in general for such purpose. Yet, these are particularly easy to spot in electron microscopy, when scanning biscuit sections with back-scattered electrons, because their atomic weight has a counterpart in the whiteness of the image that makes them stand from the background.

When experimenting with a method based in the nature and morphology of the repetitive inclusions to advance the study of the provenance of azulejos applied in Portugal we were faced with the same problem that curtails many such attempts in the field of cultural heritage: the lack of a reliable database of such inclusions found in ceramics of diverse provenance. This communication reviews the inclusions repetitively found in Portuguese 16th century azulejos as a first step for the construction of a database aimed at exploring their potential as provenance markers.

SAMPLES USED

Samples were collected from panels and tiles with known or strongly supported Portuguese origin. Whenever these panels incorporate azulejo units of different characteristics, eventually of different chronologies including later restorations, only the earliest azulejos, usually with red or reddish biscuits (the colour of the biscuits derives both from their composition and the firing cycles) were considered. Confirmation of the antiquity of each sample was based on morphological and compositional characteristics that are unique to this provenance and period and will be individually dealt with in communications presented to this conference. The panels considered were as follows:

2.1. Renaissance panels at *Igreja da Graça* in Lisbon [9], signed with the monogram of João de Góis who was active in Lisbon after ca.1558 - figure 1. Samples from this panel are identified with the code Az013/xx in which “xx” is an alfa-numeric code unique to each test item;

2.2. Renaissance panels lining *Capela de São Roque* in Lisbon, signed “Francisco de Matos” and dated 1584 (a study of these panels will be presented in GlazeArt2018 and be published separately)- figure 2. Samples from this panel are identified with the code Az068/xx;

2.3. Renaissance panel called “de Nossa Senhora da Vida” once in the now demolished *Igreja de Santo André* (Church of St. Andrew) in Lisbon and presently at the Museu Nacional do Azulejo and tentatively dated to ca. 1580 (a study of these panels supporting their Portuguese origin will be presented in GlazeArt2018 and be published separately)- figure 3. Samples from this panel are identified with the code Az032/xx.



Figure 1: An aspect of the dispersed 16th century panel at *Igreja da Graça* in Lisbon



Figure 2: An aspect of the 16th century panel dated "1584" at *Capela de São Roque*, Lisbon



Figure 3: An aspect of the *Painel de Nossa Senhora da Vida* once in the now demolished *Igreja de Santo André* and now displayed at the *Museu Nacional do Azulejo* in Lisbon

SEM-EDS ANALYSIS

The panels were sampled and the samples were stabilized in resin, cut so that a transversal section is obtained and polished for observation and analysis by scanning-electron microscopy coupled with energy-dispersive spectrometry (SEM-EDS). Figure 4 depicts one of the small samples with inclusions of potential interest marked for closer observation and eventual analysis.

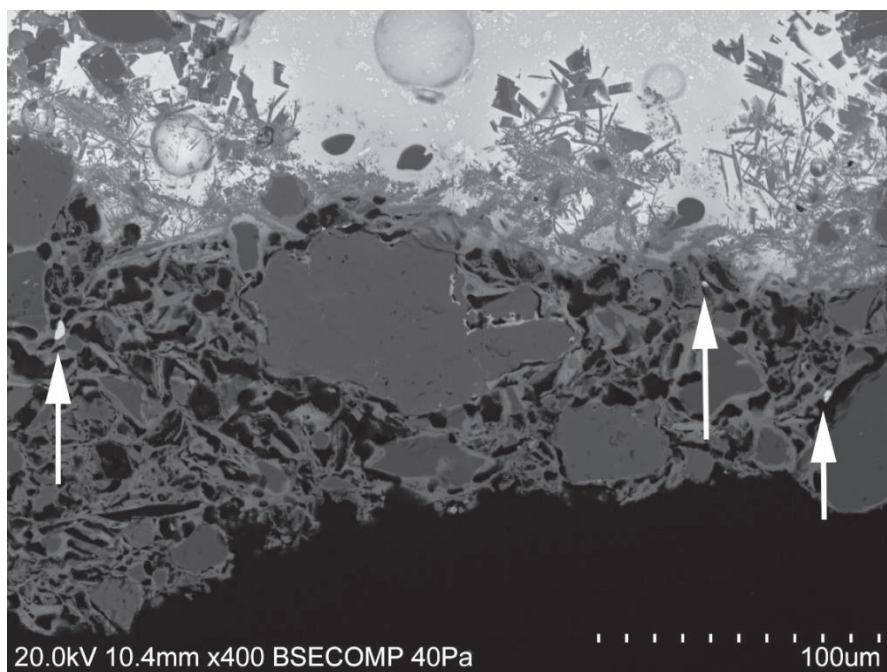


Figure 4: An aspect of part of the biscuit and interface with the glaze of sample Az068/02 (*Capela de São Roque*) with inclusions of potential interest marked for analysis

SEM-EDS observations and analyses were made at the HERCULES Laboratory in Évora using a HITACHI 3700N SEM coupled to a BRUKER XFlash 5010 EDS. Samples were uncoated and observations were made in back-scattering mode (BSE) with air in the chamber at a pressure of 40Pa and at an accelerating voltage of 20.0 kV.

A SYSTEMATIZATION OF INCLUSIONS FOUND IN THE BISCUITS OF 16th CENTURY PORTUGUESE AZULEJOS

The inclusions can be systematized in three main types: i) morphological mineral inclusions are those that are not fossils but nevertheless have a distinctive morphology; ii) specks of minerals (without apparent morphological content); and iii) presumptive microfossils.

Morphological mineral inclusions

Framboids

The most common inclusions of this type are framboid structures and related micro-spherules (figures 5, 6, 7, 8, 9).

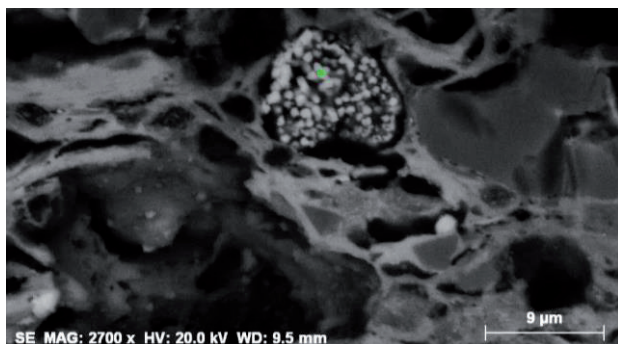
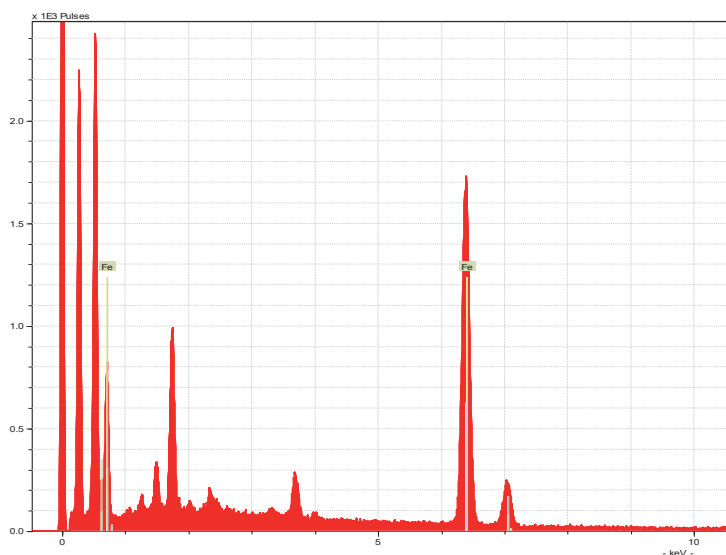


Figure 5: Top: irregular framboid of a Fe-rich mineral (presumably once pyrite) in Az032/01; bottom: EDS spectrum at the spot marked, depicting the characteristic Fe peaks (the other peaks are due to elements in the matrix).



The Pb content in the biscuit is not nil and the coincidence of the K peaks of S with a Pb peak makes it difficult to evaluate how much of the sulphur remains after the firing of the biscuit at over 800 °C

EDS shows them to be constituted mostly of iron and oxygen (figures 10, 11). Presumably they were originally framboidal pyrite (FeS_2) that lost most of its sulphur upon firing of the ceramic and glaze.

Framboidal structures occur when nucleation is faster than crystalline growth and are particularly common in pyrite [10]. They were once thought to need an organic source as a basis for organized nucleation but researchers have been able to reproduce them in the laboratory without such precondition. A review of framboidal pyrite and its synthesis was given by Ohfugi and Rickart [10]. The same authors point to the fact that although not a requisite, structures of organic origin are often found beneath the framboid and indeed several examples found in azulejos point to an organic origin in the circular hollows where they developed or their particular aggregations.

Useful nomenclatures for the several framboid morphologies were given by Merinero et al. [11] and by Sawlowicz [12] and were followed by us.

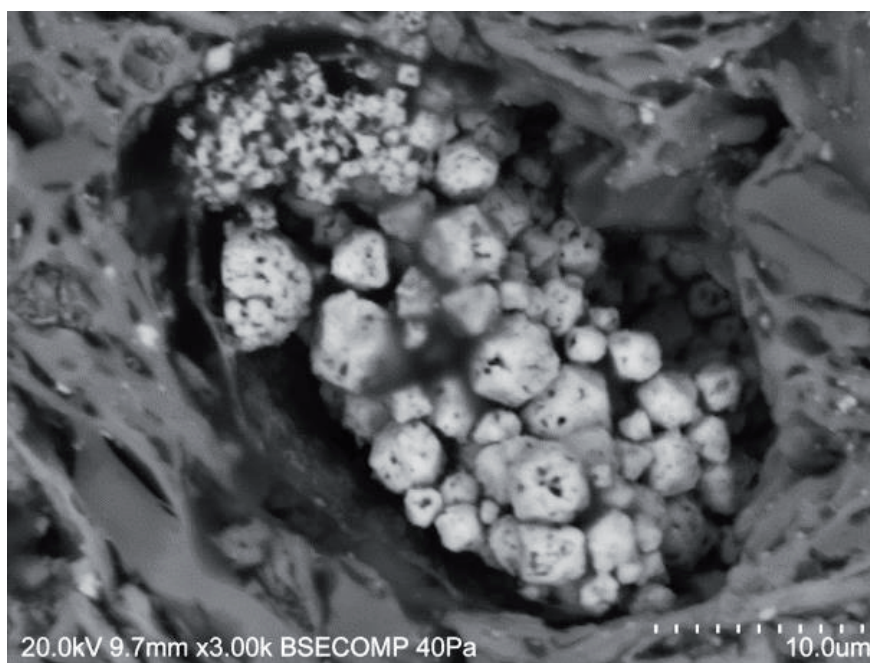


Figure 6: Irregular framboid associated with large euhedral crystals (Az 032/07)

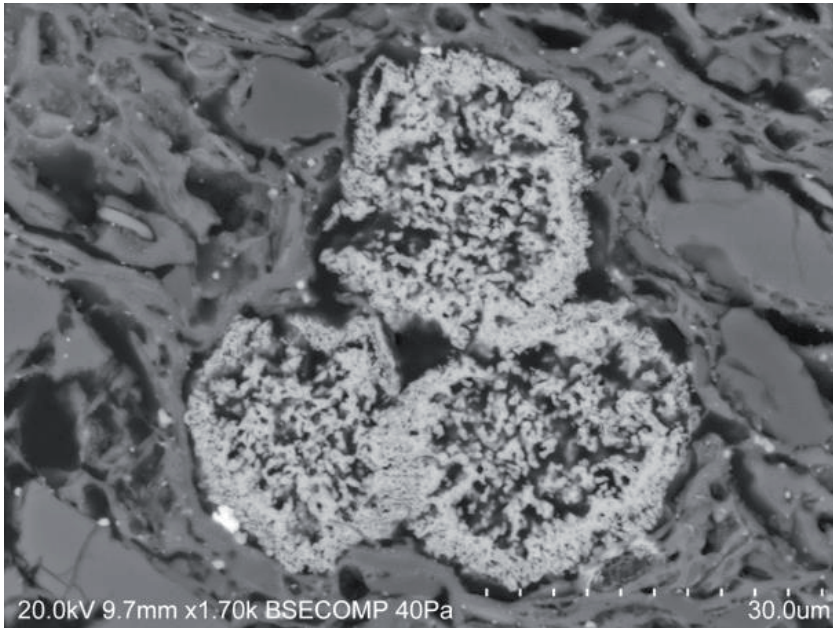


Figure 7: Annular framboids (Az 032/07)

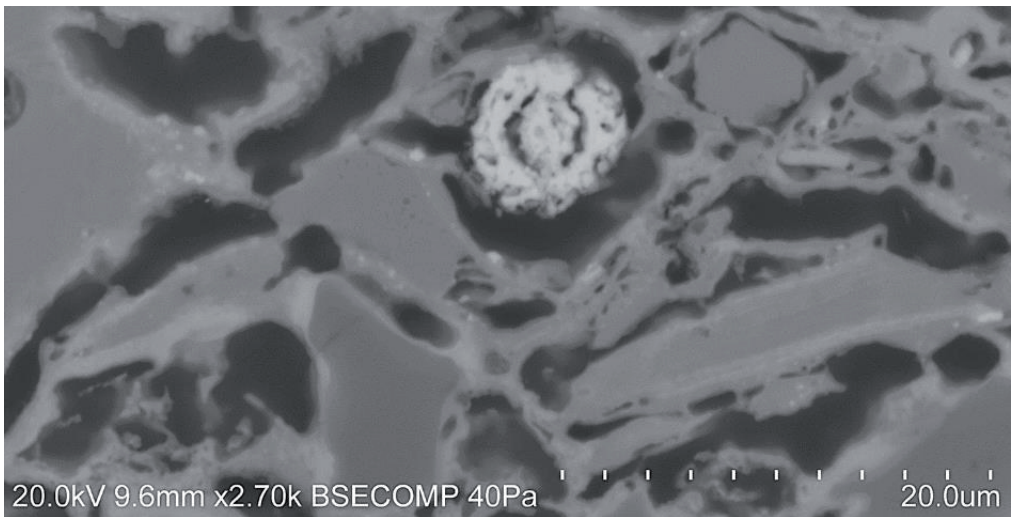


Figure 8: Annular framboid (?) with central area in separation (sample Az068/06)

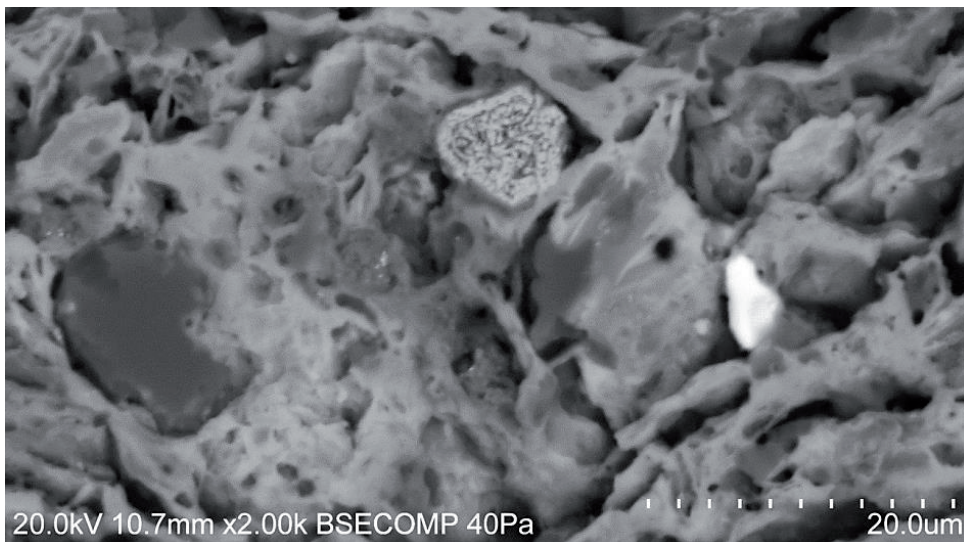
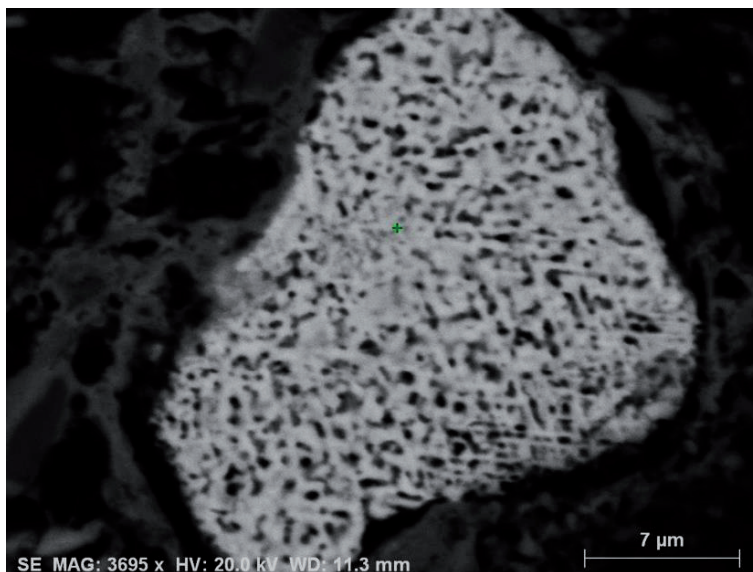


Figure 9: Euhedral-shaped crystal with framboidal core (sample Az032/04)

Structured crystals of an iron-titanium mineral

A mineral rich in Fe and Ti, probably ilmenite (FeTiO_3) is common in the shape of small featureless inclusions. Sometimes, however, it is found as needle-like or twinned crystals seen at the bottom right side of the inclusion pictured in figure 10. Here the crystals are agglomerated but twinned crystals also occur free in the ceramic matrix.



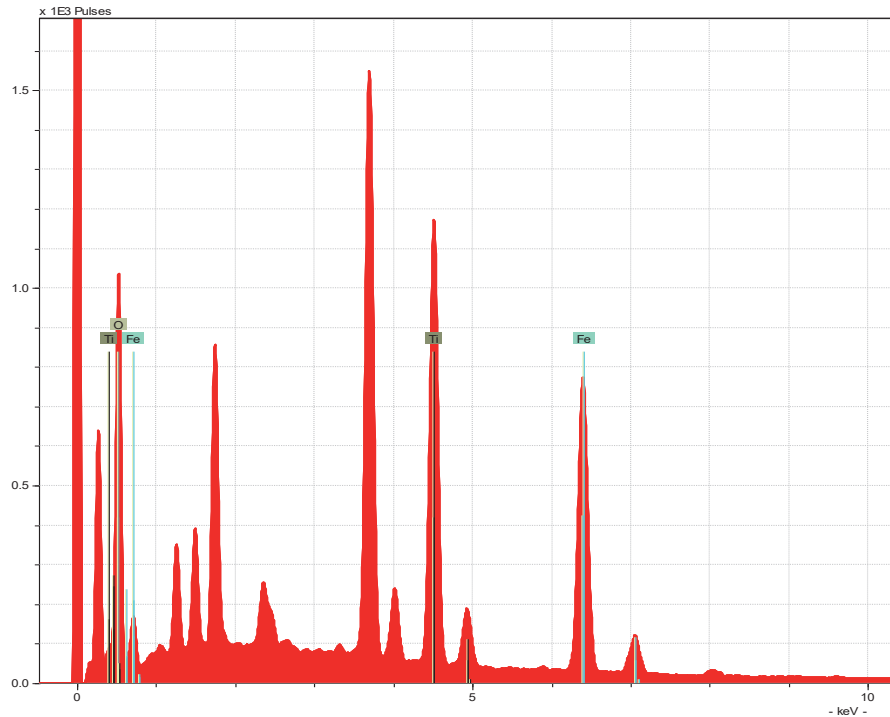
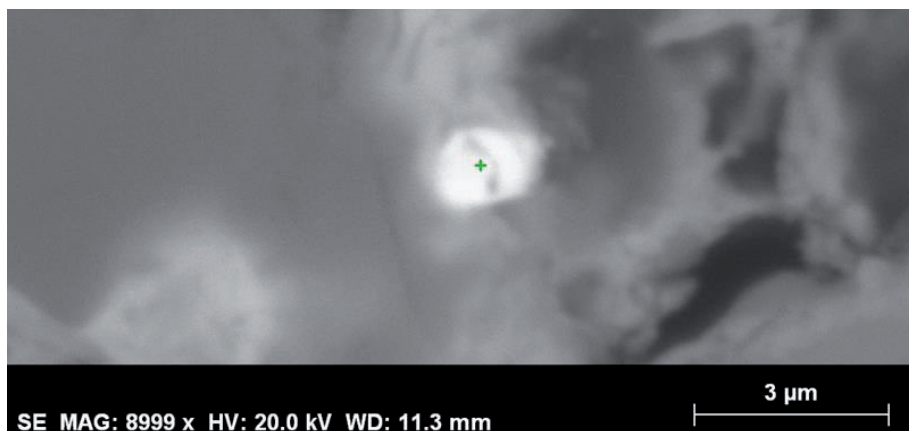


Figure 10: Top: mineral inclusion in the biscuit of sample Az013/07, rich in Fe and Ti; bottom: EDS spectrum depicting the substantial elements (the other peaks are probably due to elements in the matrix)

Zircon crystals

Zircon ($ZrSiO_4$) is relatively common as fragmented crystals but it may also be found as complete crystals (figures 11, 12) in which case they are often readily identified.



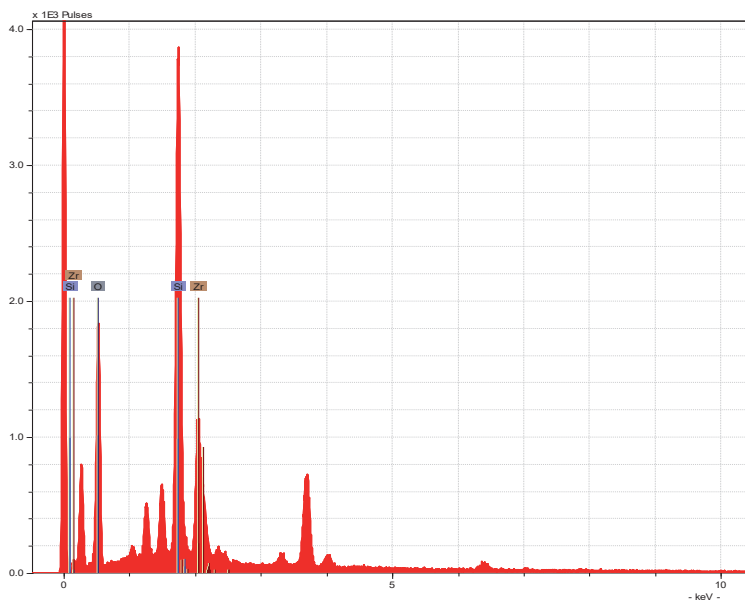


Figure 11: Top: zircon crystal in Az013/07 - such crystals are often seen with an ellipsoidal geometry because their upper face is polished off during the sample preparation; bottom: EDS spectrum at the spot marked depicting the peaks of the relevant elements (the other peaks are due to elements in the matrix)

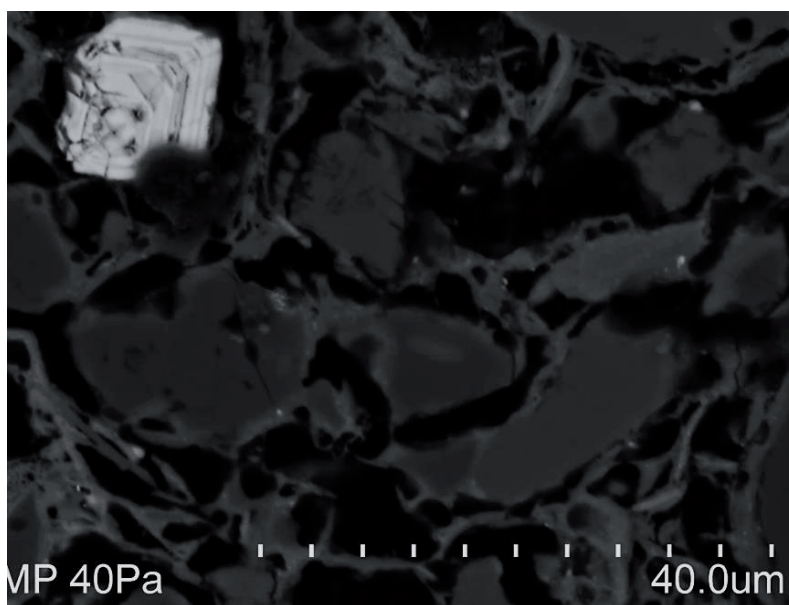


Figure 12: BSE image of a zircon crystal with inner growth marks apparent (Az068/06)

Specks of minerals

Specks of iron and titanium oxides have not been included because their ubiquity renders them of little value as markers of provenance.

The Tagus-Sado river basins began forming in the Cenozoic [13] and the rivers brought with them to what today is the region of Lisbon sediments from the interior of the Iberian Peninsula. These sediments are the origin of a number of inclusions of heavy elements minerals.

Gold

The fact that the Tagus River bears gold is well-known since Antiquity [14]. The occurrence of gold inclusions is not unusual in the biscuits of 16th century azulejos produced in Lisbon (figure 13).

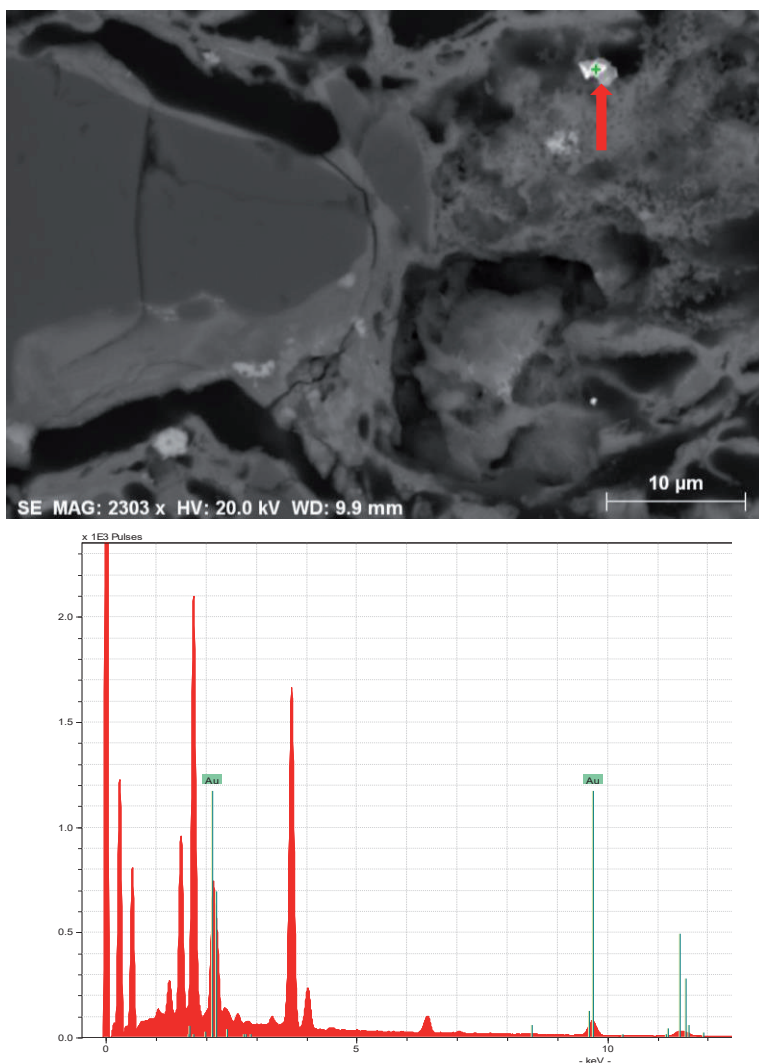


Figure 13: Top: inclusion of gold in Az068/06; bottom: EDS spectrum at the spot marked depicting the characteristic Au peaks (the other peaks are due to elements in the matrix)

Monazite (Ce)

Monazite (Ce) - $(\text{Ce}, \text{La}, \text{Nd}, \text{Th}) \text{PO}_4$ - is relatively common in most all samples examined and the inclusions are featureless (figure 14). Two main types are apparent: Th-poor mineral in which the EDS content ratio in weight Th/Ce approaches zero (figure 15 top) and Th-rich mineral in which the ratio in weight is typically > 0.5 (figure 15 bottom). Comparing the EDS spectra of both types of monazite in figure 15, corresponding to monazite (Ce) inclusions in the same sample, the peaks that define the presence of Th ($\text{M}\alpha_1$ and $\text{M}\beta$, indicated in the graphs by the two consecutive vertical marks, the first of which indicated by “Th”) are unapparent in the case of the first inclusion but well defined in the second.

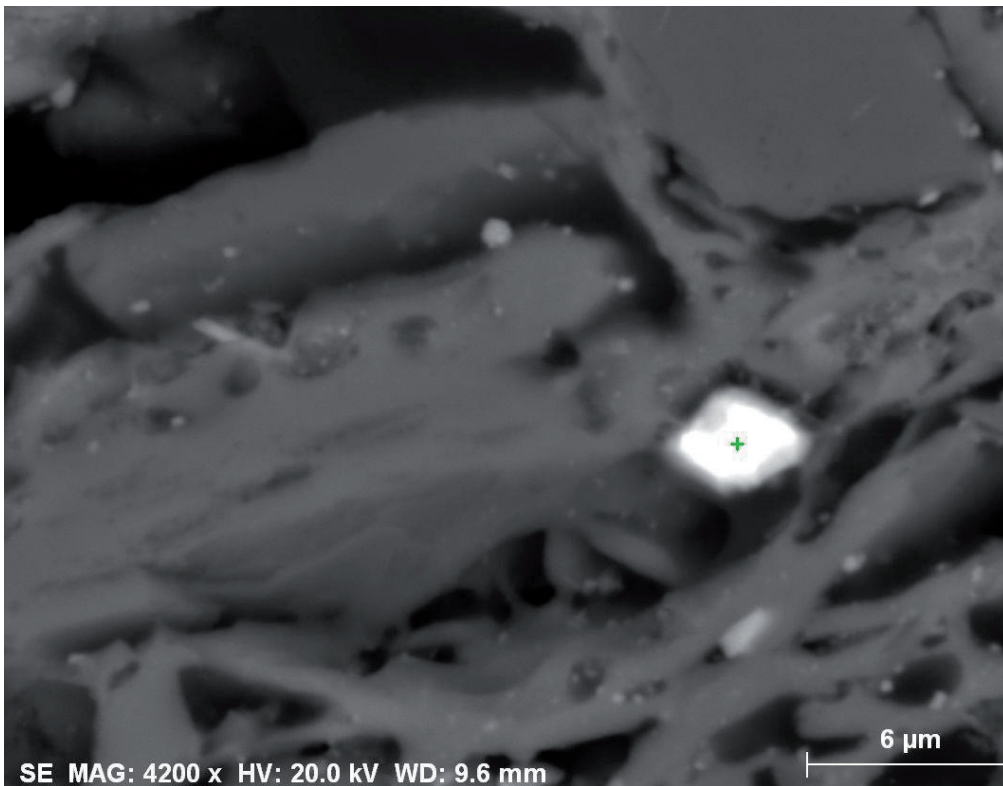


Figure 14: Typical featureless inclusion of monazite in sample Az032/07

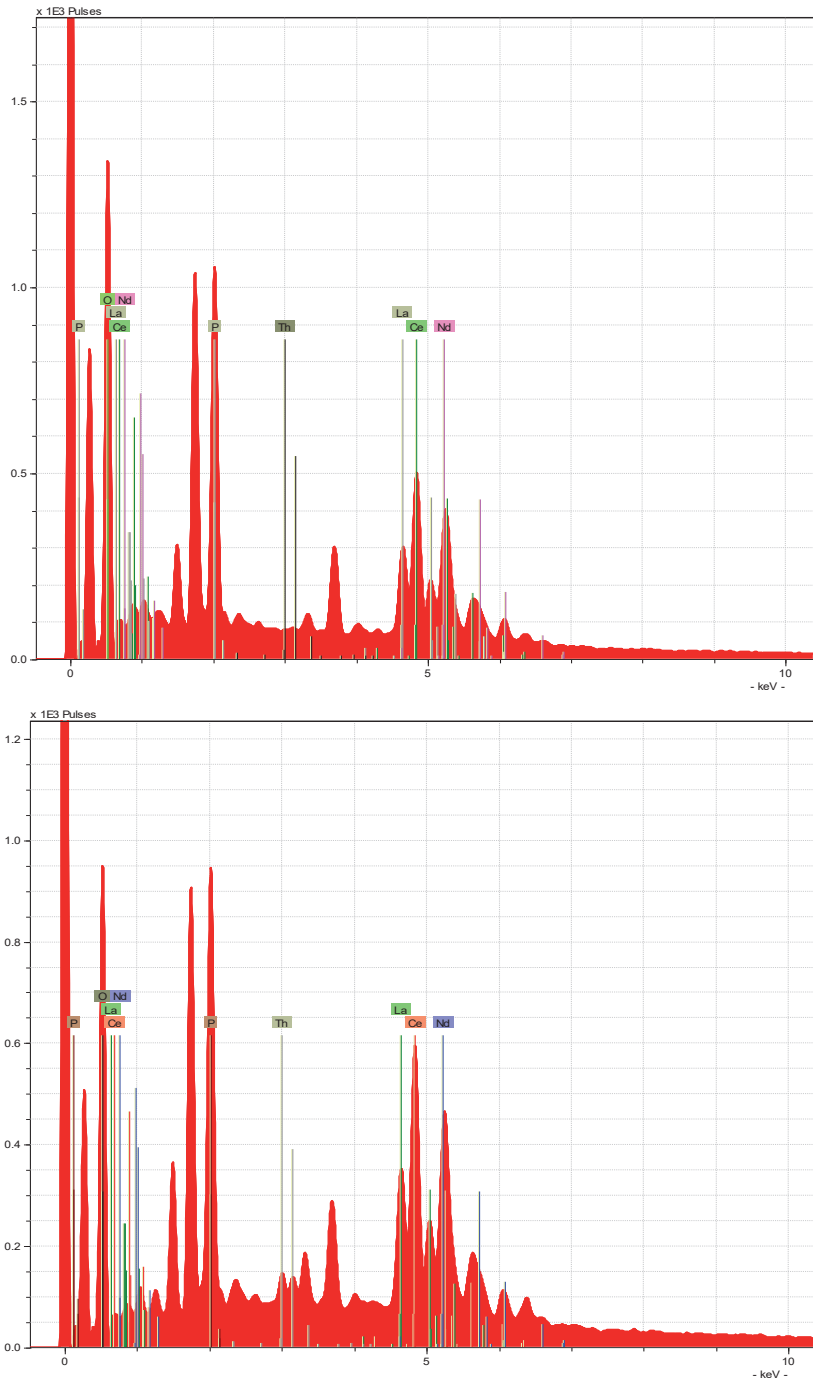


Figure 15: EDS spectra of (Ce) monazite inclusions in Az032/04. Top: Th-poor type; bottom: Th-rich type

Xenotime

Xenotime (YPO_4) inclusions were rarely found in the sections examined. Morphologically they are featureless and similar to monazite (Ce). Besides yttrium and phosphorous (figure 16) the composition of the inclusions found may include U and a variety of rare-earth elements in low contents.

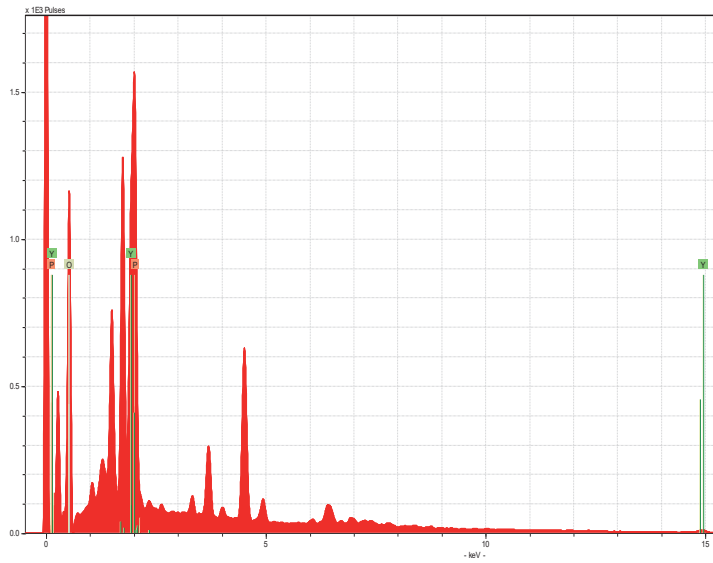
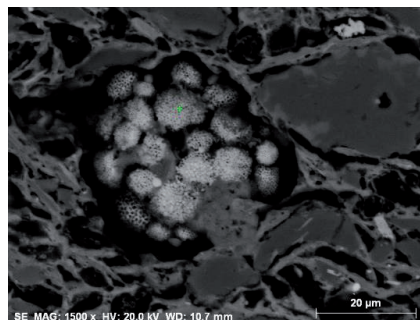
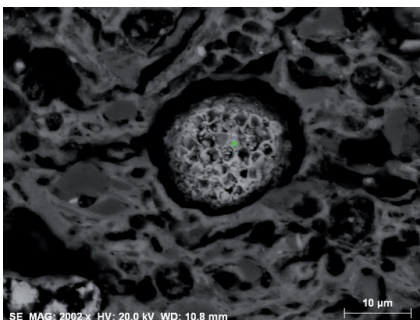


Figure 16: EDS spectrum of a xenotime inclusion in sample Az068/06.

Presumptive microfossils

In this chapter we show a number of mineral structures presumed to be fossils. Framboids are a bouquet of small spheroidal crystals. Fossil-like structures, on the other side, have the same general shape and composition but depict a multitude of what seem to be chambers (figures 17, 18, 19). Often they are lodged in circular holes suggesting biologic activity. In some cases such structures are likely crystalline growths nucleated over the test of a dead animal. They may also result from disappearing mineral framboids whose empty spaces were filled with plastic clay. Whatever their nature, their morphology is repetitive and therefore may serve as a provenance marker.



Figures 17, 18: Fossil-like structures in Az013/04. They are lodged in clear-cut holes and depict a mesh of seemingly empty chambers

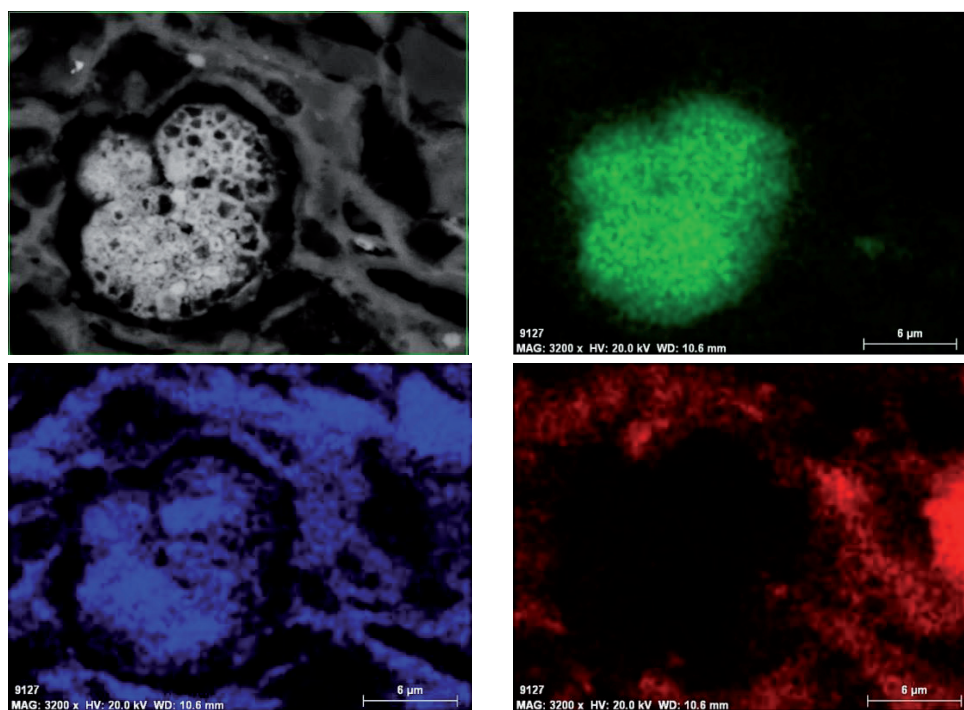


Figure 19: Fossil-like structures with chambers in Az013/04. The composition is similar to that of the framboids - elemental maps correspond to Fe (green), O (blue) and Ca (red)

5. CONCLUSION

We have presented a systematized list of inclusions repetitively found in the biscuits of 16th azulejos produced in Lisbon as well as images exemplifying the several cases. These are by no means exhaustive as we have also identified other rarer mineral inclusions that, through composition and approximate stoichiometric proportions obtained from the EDS semi-quantification, are thought to be pyromorphite - $Pb_5(PO_4)_3Cl$ and vanadinite - $Pb_5(VO_4)_3Cl$. Other inclusions containing Pb, Bi or Hg may correspond to workshop residues and may also afford additional data on that basis.

The research has to be followed by a more complete survey including accurate compositional analyses of inclusions such as monazite and xenotime, aiming at fingerprinting them from their contents in relevant minor, trace and sub-trace elements. Other geographic sources of majolica tiles such as Seville and Antwerp should also be included, with a view to determine which inclusions may profile each provenance location in the most straightforward manner. So... the results presented today are just the beginning of what we foresee as a promising new area of study in this field.

Acknowledgements

The Director of *Museu de São Roque*, Dr^a Teresa Morna, Dr. João Miguel Simões and André Martins da Silva and the remarkable *Irmandade de São Roque* are gratefully acknowledged for authorizing a limited sampling of the magnificent panels at the Capela de São Roque.

The parish Priest of *Santo André e Sta. Marinha à Graça* and Miguel Ângelo da Silva, are gratefully acknowledged for their support and enthusiasm and for repeatedly granting us access to study the remarkable panels conserved in the walls of *Igreja da Graça*.

Communication produced as an outcome of Project FCT-AzuRe - Estudos no Azulejo Português para Candidatura a Património da Humanidade (PTDC/EPH-PAT/5096/2014) funded by FCT, the Portuguese Foundation for Science and Technology.

LNEC Research Project 0202/111/19747.

Bibliographic references

1. SANTOS SIMÕES, J.M. - *Azulejaria em Portugal nos séculos XV e XVI*. 2ª edição. Fundação Calouste Gulbenkian, Lisboa, 1990.
2. DUMORTIER, Claire, *Céramique de la Renaissance à Anvers*, Editions Racine, Brussels, 2002.
3. MOLERA, J. et al. - *Interactions between Clay Bodies and Lead Glazes*, Journal of the American Ceramic Society, Vol. 84, Nr 5, May2001, pps. 1120-1128.
4. COENTRO, Susana – *An Iberian Heritage: Hispano-Moresque architectural tiles in Portuguese and Spanish collections*, PhD Thesis, Universidade Nova de Lisboa, 2017, Annex IV pps. 129-131.
5. WILLIAMS, M. et al. - *Microfossil-determined provenance of clay building materials at Burrough Hill Iron Age hill fort, Leicestershire, England*. Journal of Archaeological Science, Vol. 54, 2015, pps. 329-339.
6. QUINN, Patrick & DAY, Peter, *Ceramic micropalaeontology: the analysis of microfossils in ancient ceramics*, Journal of Micropalaeontology, Vol. 26, 2007, pps. 159-168.
7. ATTAELMANAN, Atta, *Identification of mineral inclusions in archaeological ceramics using microbeam X-ray fluorescence spectrometry*, X-Ray Spectrometry, Vol. 43, 2014, pps. 325–331.
8. MEDEGHINIA, Laura et al. *The ceramic of the “Palace of the Copper Axes” (Khirbet al-Batrawy, Jordan): a palatial special production*, Ceramics International, Vol. 42, 2016, pps. 5952–5962.
9. PAIS, A. et al. – *Graça Church Revisited* in Proc. Int. Conf. Glazed Ceramics in Cultural Heritage (GlazeArch2015), LNEC, Lisbon.
10. OHFUGI, Hiroaki & RICKART, David, *Experimental syntheses of framboids—a review*, Earth-Science Reviews Vol. 71, 2005, pps. 147–170.
11. MERINERO, R. et al. *Iron oxyhydroxide and sulphide mineralization in hydrocarbon seep-related carbonate submarine chimneys, Gulf of Cadiz (SW Iberian Peninsula)*, Marine and Petroleum Geology, Vol. 25, 2008, pps. 706-713.
12. SAWŁOWICZ, Z. *Framboids: from their origin to application*, Prace Mineralogiczne (Mineralogical Transactions), Vol. 88, 2000, pps. 1-58.
13. GALOPIM DE CARVALHO, A. et al. *Evolução paleogeográfica da bacia do Tejo-Sado*, in Boletim da Sociedade Geológica de Portugal, Vol. XXIV, 1983, pps. 209-212;
14. DEPRez, S. et al. *Roman gold exploitation in the Tagus River valley - the Cunhal of Arneiro (northeast Alentejo, Portugal): a geoarchaeological case study*, abst. in Proc. Int. Col. “Landscape Archaeology, Egypt and the Mediterranean World”, Cairo, Egypt, 19-21 Sept. 2010.

Apeiron – ἄπειρον – and Havoc: Beauty in Aalto's tiles

Joaquim Marcelino Santos

Architect, PhD, Tampere University of Technology, Tampere, Finland

Professor at the Lusitana University, Lisbon, Faculty of Architecture and Arts (UL)

CITAD, Research Center for Territory, Architecture and Design (UL)

marcelino.c.santos@gmail.com

SUMMARY: Classicism and medievalism come together in Modern Architecture as a symbol of the ancestry of man and of western civilization. Yet, such cross roads were also explored by architects to comprehensively develop their own styles. In addition, the overwhelming sense of an «international revolution» in architecture and civilization will produce a manifestation of regional cultures. In this context, the glazed tiles in Aalto's oeuvre seem interesting to explore because they symbolise the erudition of classicism, the importance of craftsmanship and also, the importance of industry under the full control of human will.

KEY-WORDS: Aalto, Saarinen, tiles, Finnish, Functionalism

INTRODUCTION

Had not Xenophanes created the *apeiron*, Aalto's tiles would never have been created!

The symbolic representation of the *apeiron* in the Doric, Ionic and Corinthian is certainly a *motif* that links them and its metamorphosis into a coloured tile that has acquired special significance in Aalto's oeuvre. Yet, in Aalto the outer circle of the *anathyrōsis* has acquired some life of its own. Perhaps as a consequence of an intricate multiple reference in which post-Enlightenment analytical construction regarding pillars, floor slabs and walls combines with cubist ideals. Namely, work on the essence of the object in space-time and the expressionist unity between an inner and outer world of mind are to be expressed par excellence through the object.

The presence of the tile expresses and combines different arguments where the classical tradition, the vernacular tradition and craftsmanship coincide. Herman Gesellius, Armas Lindgren and Eliel Saarinen had already given a high erudite and mature interpretation of the tiles at the Helsinki Central Railways Station and established some equivalence in relation to materiality and aesthetic expression from tile to plaster and to stone.

Aalto's famous curved tile presents breadth that is permeable to work in a sense of scale that combines the Classical and the Functionalist. A sense of architectural promenade that may suggest a *quantum continuum*, and that is a multidimensional infusion of the individual into space. This is due to several strategies and includes the distribution of tile within space. Thereby, emerges the sense of tile as a structural surface that disputes its rule with both finished and coated layers with main structural parts of the building. All of which can be regarded as a critical constructivist reading, and as ornament.

Tiles as structural surfaces are, somehow, new or recreated afresh. Yet Gesellius-Lindgren-Saarinen created a strong architectural discourse in this direction and, besides, the Finnish fireplace acquired a strong cultural meaning. Where the characteristic tiles that were somehow, a combination of an inner structure and a finished surface that presented structure whose visibility

was given by the tile size. Akseli Gallen-Kallela did not forget this important core of architecture in his studio, nor did Saarinen in Hvitträsk.



Figs. 1, 2: Herman Gesellius, Armas Lindgren and Eliel Saarinen Eliel Saarinen. Eliel Saarinen's studio and residence, Hvitträsk, 1901-1903.

Close observation of Aalto's work on tiles versus ornament versus construction gives us some curious surprises. Are the *fake* metallic tiles at the main façade of the National Pensions Institute in Helsinki referenceable to tiles, to bricks or to terracotta?

Indeed, there is a more complex approach to tiles held by Aalto. The use of different materials and motifs that create an architectural promenade may establish an equivalence among them and such equivalence would then recreate each of those materials and motifs afresh. Those materials and motifs will then extend and partake aesthetic qualities that were not known formerly. Perhaps this is the most difficult feature of architecture, but it is also a particularly fruitful one.

Last but not least, apart from Aalto's oeuvre it is the development of the tile industry that later will highlight Partek, a famous Finnish company, that manufactured the special tiles that cover Jørn Utzon's Sydney Opera House. The tiles mark distinctive relation to forms and shapes that fly out between the water of the harbour and the sky. Yet, we may say that this is not a mere curiosity. But we may think about how far Aalto's work on tiles was a vehicle to recreate afresh an ancient tradition of tiles from craftsmanship to a remarkable role in architectural space and time.

GLAZED FREE ARCHITECTURE

Aalto's Villa Tammekann, in Tartu, Estonia (1932-1933), belongs to the same type of approach that Alvar Aalto (1898-1976) and Aino Marsio-Aalto (1894-1949) worked on the Viipuri Library (1927-1933) and on the Paimio Sanatorium (1929-1932). The white option was related to the affirmation of concise articulated volumes but was not a definitive option because colours were articulated with those volumes. Despite the importance of the iconic colour scheme in the impressive narrow high façade of Paimio, colour was mostly a strong strategy to inner spaces. Yet, later, strong colour arguments are found in both inner and outer spaces and the glazed tiles perform a major role in overall spatial articulation along with stone, masonry and bricks.

The white glazed tiles on the kitchen wall of the Villa Tammekann were closely related to the overall functionalism of the house and of the kitchen rather to some kind of classical interpretation of the classical orders that are found later in Aalto's mature years. In fact, at this time, Aalto seems to refuse all classical ornament. As Göran Schildt notices "The second version of the Viipuri City Library (V.4.2) was shorn of all Classicist ornament." Yet, the masonry displayed at the inner space of Villa Tammekann seems to recall other types of ornament to be combined with bold white arguments.

But glazed architecture was certainly a strong issue in architecture. Adolf Loos (1870-1933) takes the idea to an extreme in the Villa Müller in Prague (1928-1930). Regarding the *Raumplan*, we may say that Loos's actual glass tiles define walls and therefore we can hardly understand them as decorative, but as actual space boundaries that demand a unique expression that give a spiritual experience to individuals. In this context, the stained-glass windows of the cathedral seem to be a closer reference and yet that is not certainly true of Loos, but can easily be argued as a strong reference to Bruno Taut and to his *Glashauss* (1914) due to have evidence from his drawings of his passion for the cathedral-in-glass.

The nineteenth century iron-glass architecture put glass at the core of architecture, but not necessarily the glazed tile and this is the reason why Loos solution seems so original. The opaque glass tiles strongly discuss the light that transforms the surface by the metamorphosis of reflection as we walk through and thus they are comprehensively used as a *spatio-temporal* chronology to the *Raumplan*. Thus, on this sense, their use seems strongly classical following the roles of the dynamics of perspective such as it has been developed along the Renaissance, the Mannerism, the Baroque and the Neoclassical. The linearity of the corridor is an abstraction that differs much from the actual aesthetic experience that it provides and there are the particular characteristics of the glass tiles that make such a long-term interpretation of the classical architecture possible.

GLAZED ARCHITECTURE

Loos architecture came to discussion because of his particular attention to Greek architecture where he found a perfect harmony between the overall conception of the building and its ornament and this cultural background was also strongly important to Aino and Alvar Aalto. Yet, in the same way that Loos traces the origins of architecture to the cave and to the ceiling as shelter, Laugier had given the primitive hut a tectonic reading in his *Essai sur L'Architecture* (1755), and this idea seemed particularly important to an overwhelming reading of the architectural form at any age including the neoclassical architecture and the new glass-iron architecture as well as to vernacular architecture. However, these two ideas that were settled apart seem to combine because architecture is a *spatio-temporal* construction organised by a materiality of some kind that must not avoid the laws of physics.

In general, Modern Architecture was looking for a scientific background. Even the Gestalt was a search for a scientific ground to perception and to aesthetics. Rationality was a demand that architecture could not avoid. But Modern Architecture put forward some delicate problems that could be summarized to understand the role of this new architecture in history and this is the task that Sigfried Giedion took in his hands in "Space, Time and Architecture. The Growth of a New Tradition" (first published in 1941). His views were particularly attractive and the effects in contemporary architectural theory and practice have not been discussed enough. In short, the distinction between Le Corbusier's rational architecture and Alvar Aalto and Frank Lloyd Wright's sensible architecture created a rational strategy for reading the history as well as Modern Architecture, but much remained to be explained. Thus, even today, only few scholars approach Aalto as a rational mind and most of them prefer to use Aalto's oeuvre as symbol of the sensible and thus suitable for approaches such as the phenomenological that, nonetheless, remains particularly incomplete in many cases.

Nordic Classicism

The role of the Nordic Classicism should not be forgotten when approaching Scandinavian Modern Architecture and thus the role of Palladio cannot be forgotten, too. We find a strong Palladian influence in Aalto's early works. But we also find such an influence in architects such as Eric Gunnar Asplund (1885-1940) who was a strong reference to Aalto.

The Woodland Cemetery (1917-1940) crowded by the colonnade owes much to Palladio's strategy of approaching the site to build villas but the Villa Snellman needs some further attention regarding the role of rationality as such. The «imperfect» 'L' shape and the different rhythms of the windows that distinguish the ground floor from the upper floor display a certain kind of freedom versus rationality that only a critical eye of the classicism could create.

Palladio introduced a compromise between rationality and subjectivity and thus the latter can be a strong manifestation of the reflective mind, too. Palladio stated that "There are also other heights for vaults, which do not come under any rule, and therefore are left for the architect to make use of as necessity requires, and according to his judgement"¹. On this basis, the way is opened for further exploration of classicism itself and also with new formulae such as *form-follows-function*. Thus, a deterministic rule might be questioned from its outset, but this fact does not mean that classicism became an easy issue.

Scandinavian architects such as Asplund and Aalto decided to explore classicism and we may say that there were two major reasons at the background. To belong to a classical, wide-ranging tradition presented a cultural statement that was meant to demonstrate an accurate knowledge of Mediterranean culture. And, on the other hand, to show the capacity of recreating it afresh according to universal values. Further we may not forget that the pursuit of Modern Architecture and universal humanist values are grounded in this approach.

However, there is a final argument that is very important to the Finns and to their culture. Ultima Thule was the name that Greeks gave to this far northern land of granite, water and forests. Thule meant the northernmost location of the ancient world. Thus, from its beginning, the strength of Classical Culture was crucial by identifying a *modus vivendi* of a peculiar civilization. Greeks have thus brought the Finnish Culture into the civilization. Finland was in the far north, but it was there, indeed.

Apeiron – ἄπειρον – and Havoc

Classical orders have been recreated afresh through history. For instance, as John Summerson puts it, "*Borromini's orders are outrageous and extremely expressive inventions, entirely of his own. So it is a mistake ever to think of the five orders of architecture as a sort of child's box of bricks which architects have used to save themselves the trouble of inventing. It is much better to think of them as grammatical expressions imposing a formidable discipline, but a discipline within which personal sensibility always has a certain play – a discipline, moreover, which can sometimes be burst asunder by a flight of poetic genius.*"² And thus, there was a criterion regarding the placement of the ornament in the building. The capital and the superstructure of the order opposed to some extent to the body of the column.

When Philibert de l'Orme created the French Order in 1567, it "gave logical expression to the fact that a column was composed of several separate stones"³ and thus ornament was placed under a new rule. This was unlike the classical tradition because one of the rules of the *anathyrōsis* was to create a constructive continuity of a perfect object in its relation to the cosmos. The other rule was to illustrate that the cosmos inside the stone cut itself, an illustration not to be seen that, nonetheless, was critical in technological and symbolic meaning. Furthermore, the technical and technological skills that the Greeks have inherited from Egypt regarding the *anathyrōsis* would not make them think about anything else, but the continuity through the different stone blocks.

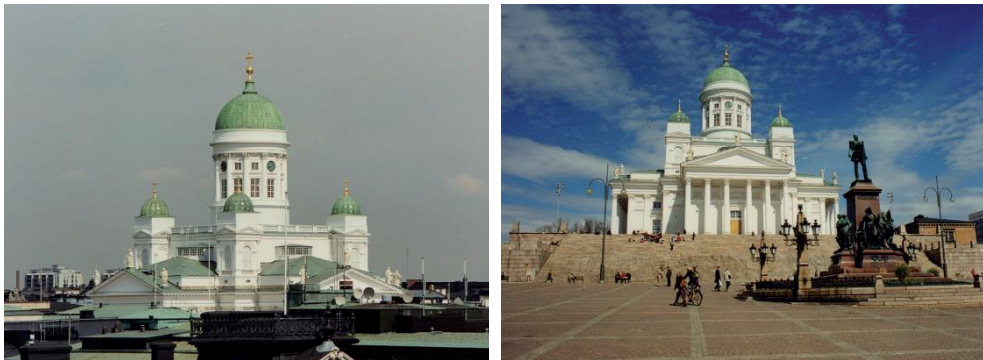
Philibert de l'Orme approach introduced another novelty. We could say that any accurate reading of the orders would ever touch the continuity of the vertical of the body of the columns nervures because such detail was not ornament but understood as an accurate representation of apeiron and thus those nervures belonged to the perfect geometrico-mathematization of the intimate linkage between the building and the cosmos. Thus, such relations were unbreakable, sacred.

Reversing the classical language and the role of the order

The clarity of Finnish Classicism, the white orders of Carl Ludvig Engel (1778-1840) displayed through several iconic buildings such as the Helsinki Cathedral (1830-1852) seem to leave little room for further recreation. The main strategy used by architects was always a strategy of proportion according to pursuit a specific end that could be an accurate reading of history or, rather, to create a strong subjective effect such as Francesco Borromini (1599-1667) did in *S. Carlo alle Quattro Fontane*, in Rome (1665-1667). Yet, the crossing lines of the Enlightenment and the Neoclassical seemed to refuse subjectivity and to demand aesthetic judgement to be rational and logical. Thus, the rule of Palladio might have been the most important phenomenon when Scandinavian countries and Finland, following independence, were looking for an important position in western culture in its linkage to the Mediterranean.

The Finnish challenge was huge, but architects such as Carl Ludvig Engel, Lars Sonck (1870-1956) and Eliel Saarinen (1873-1950) had already built a comprehensive revelation of the Finnish Culture. From the classical to the vernacular, their works were already speaking by themselves and other works such as the Akseli Gallen-Kallela's studio (1911-1913) were giving special attention to the National Romantic that was already building the housing areas in Helsinki.

Yet Gallen-Kallela (1865-1931) is not known for his studio but by the fact the he was the key figure by giving a contemporary figurative expression to the national poem Kalevala that took Finnish painting in parallel to the development of the Avant-garde. Thus, the Finnish Modern Art was going to pay attention to painting, sculpture, architecture and design and also to urbanism where we find Eliel Saarinen's designs to the large Helsinki.



Figs. 3, 4: Carl Ludvig Engel. Helsinki Cathedral, 1830-1852.

Thus, in some sense, in a particularly short time there was a growing atmosphere of freedom and creativity to which we may note the early admission of women to the academy that in short time gave rise to architects such as Aino Marsio. Yet, the classical was the dominant strategy at the academy and this is the reason why Aino-Alvar Aalto's first functionalist buildings were so important in Finland and abroad. But we must not forget how hard it was for such architecture to be accepted in Finland and how long it took. This is a forgotten history and yet of a major importance.

The first building referable to the beginning of the Modern Architecture was not Aalto's but Eliel Saarinen's Helsinki Railways Station (1904-1913). The clear use of the geometrical organization regarding function owes much to classicism and comprises many arguments of symmetry versus asymmetry which are particularly creative. Also, the discourse of materials is very effective. There is a comprehensive articulation of stone masonry and plaster surfaces and last but not the least, the green glaze plays a major role on the magnitude of the inner space. The «wavy» motif,

that can be read in different ways such as having a floral root, created a balance between the tectonic of the vertical elements that are thus stressed as a decorative motif that now belongs to the body of a tectonic order that seems to be more important than its capital.



Fig. 5: Eliel Saarinen. Helsinki Railway Station, 1904-1913.

The constructive reference to the classic composition and construction of the building is there but we now have a new narrative. The «apeiron» has been converted into a new atmosphere which, curiously, interferes more strongly in the space it defines. The three-dimensionality of the glazed tiles work in both ways, as furnishing a surface and also as a constructive thing that has a tectonic value of itself. Thus, the glazed tile became particularly important at the birth of Modern Architecture in Finland, but it took some time for Aalto use the glazed tiles.



Figs. 6, 7: Eliel Saarinen. Helsinki Railway Station, 1904-1913.

The role of the order: proportion and ornament

Since the Renaissance the Greek and the Roman approaches to classicism were under criticism. The self-sufficient column of the Greeks opposed to the extensive use of the wall of Roman architecture that concrete made effective. Yet, the wall remained an important problem to be solved in relation to the orders. Alberti's innovation in Palazzo Rucellai, in Florence (1446-1451), created a formula that could simultaneously brought in a closed relationship to history using the coliseum. But the wall itself is space, a screen for events, that remains to be understood. Frescoes soon became a suitable strategy to create the inner spaces that thus emerge as distinct from the façades.

Perhaps, this is a too short description of architecture that has moments as for those of the Baroque in which the articulation of curved walls and orders gave place to complex structural solutions. Yet, even this tectonic novelty led to an increase in the understanding of the complexity

of the wall from the structural to the ornament. And this is the phenomenon that may help understand the way in which Aalto displays tiles in his architecture.

Order crosses the metaphor of the human body with its basic tectonic materiality. There is the base and the top and between them the body of the column. Basically, three parts attached together that organize a system of proportions. Yet the metaphor seems too short to be effective in functional terms but the same does not happen with the *geometrico-mathematization* of the plan that may be effective and may not be related to the vertical proportion of an order. In this sense, the order itself has gained more freedom.

In line with this type of approach is the fact that there is something rational in the basis of the argument. Accordingly, such rationality needs a judgement of the architect in order to find a solution afresh. This atmosphere clearly reflects the Palladian strategy in which the architect is called to exercise his freedom by a judgement. Thus, Aalto's strategy is a possible one among many because the different ages of classicism have shown that classicism is more likely to open ways rather than to create narrow views.

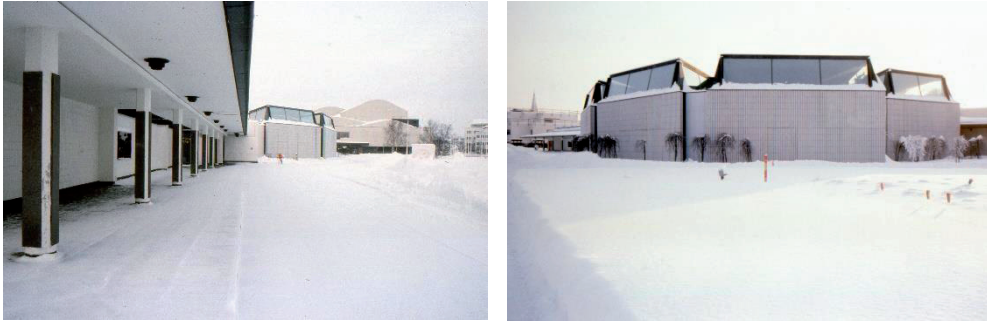
A basic relation between the ground and the ceiling is established giving some architectural substance to the void that is experienced. Thus, there is something basic in the column that relates to us but that the abstraction of the metaphor may be incomplete. Aalto prefers to work with *pillar-like-columns* rather than with Le Corbusier's *pilotis* even if both may be traced back to classicism. Thus glazed tiles perform a major role in this approach.

Aalto's glazed tiles present a comprehensive criticism of the column in which it becomes a *spatio-temporal* element that organises the architectural discourse and our presence in it. And Aalto used a few colours, too. The distance from the floor to the line where tiles start is always different from the distance where they end to the ceiling. There is a clear discourse that is also tectonic by identifying the different parts of the architectural composition of space. Yet, Aalto's curved glazed tiles display a certain depth. They are actual three-dimensional elements. So, on a similar way to Eliel Saarinen's green glazed tiles in the Helsinki Railway station, Aalto's tiles construct a three-dimensional surface of solids and voids whose vertical expression owes much to the *apeiron* of the Greek columns.

Aalto's attitude also means that he reversed the classical order extensively because the base and the top appear free of any ornament and the later has been moved to the body of the column. This means that Aalto actually had a deep knowledge of classicism and the simplification of volumes provided by the Architects of the Revolution was short to answer the problems of the Functionalism.

The role of the order: The *architectural promenade*

The pillar-like-columns will stand firmly as Aalto's motifs, but their strength does not live of the column alone. The glazed tiles are displayed outside and inside the buildings. Also, a certain equivalence between the glazed tile and the brick is found when we bring together buildings such the House of Culture, in Helsinki (1955-58), the Helsinki University of Technology, in Otaniemi (1949-1976) and in a particular way the buildings of the new Seinäjoki public centre. But the white glazed bricks that we find in the Rovaniemi Library are special, too.



Figs. 8, 9: Alvar Aalto. Rovaniemi City Library, 1961-68.

In general, Aalto has explored coloured tiles comprehensively in the construction of architectural promenades. And there are also fake tiles, too. The National Pensions Institute headquarters (1948-1957), in Helsinki, is one of those buildings where metamorphosis of glazed tiles is found. The façade facing *Mannerheimintie* at the *Messeniuksenkatu-Nordenskiöldinkatu* crossing displays a particularly interesting aesthetic exploration of fake glazed tiles that are made of copper alloy sheet. They are metallic and construct a discourse of their own where the traditional glazed tiles and the bricks are referable.

The fact that they are vertically applied opposes the horizontal disposition of the bricks we find in the upper floors and on other parts of the building. Thus, by giving different tectonic meanings to the materials the fake tiles behave much as surface finishing and yet display a strong meaning of the surface as an actual object due to the thickness of these «tiles». Indeed, metamorphosis in tile-like structures and their tectonics are efficiently explored in Aalto's works.

This short remark on the National Pensions Institute may seem that we have forgotten the order in itself, but that is not actually the case. In fact, there is an extensive reference to classical architecture in Aalto's work and here we have a very typical one. We can say that Aalto stressed the anthropomorphic character of the *palazzo* and the role of the fake metallic tiles is particularly important on interpretation of this character. Besides, that anthropomorphic character is deeply rooted in the classical orders. Yet, there are buildings such as the House of Culture, in Helsinki, where such character is stressed by a colonnade in a way that makes one think on the Stoa.

The blue glazed tiles of Seinäjoki

The blue glazed tiles are a distinct mark of Seinäjoki. However, there are white and blue tiles, and there are the black stone and white plastered walls. Perhaps the poetic synthesis of all the main arguments is the large glazed window at the Parish Centre where the blue and the white mutually construct each other in what we may think of in other art works like the work of Henri Matisse at the *Chapelle du Rosaire* (1949-1951), in Vence, France. Aalto certainly simplified the colours in a white-blue dialog, but, on the other hand, he explored deeply, the dynamics of line and of surface in interaction with architectural space.



Figs. 10: Alvar Aalto. Seinäjoki Parish facilities and vicarage, 1964-1966 (Church 1958-1960).

Differentiation of colour as well as the way in which the glazed tiles are applied on the walls created an architectural promenade that takes us to the upper floor. The glazed tiles are critical as they create changes in the way the space is perceived. That is, there is a «first» layer of basic geometric organization that already structures the basic intentions of the space regarding functional organization. But it is a second argument, or ornament, given by glazed tiles that give the architectural space proper scale. Also, there are the seen and the un-seen tiles that we feel we are going to discover as we move through the space and such discovery reveals different relations to space that were not previously seen and would have been barely imaginable. Consequently, there is a rich aesthetic experience that is glazed tiles based in an extensive way. However, photographs often tell little due to the strong continuity of space and time that combines the architectural discourse.



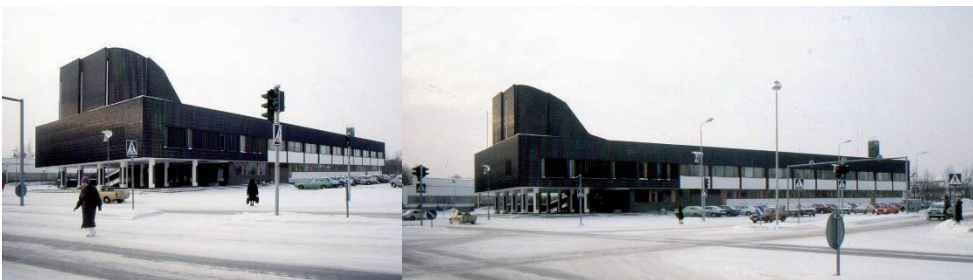
Fig. 11: Alvar Aalto. Seinäjoki Town Hall, 1959-1965 (parish facilities on foreground, right).



Figs. 12, 13: Alvar Aalto. Seinäjoki Town Hall, 1959-1965.

This experience of the interior space starts at the portico of the Seinäjoki Town Hall that does not present glazed tiles furnishing its pillar-like-columns. Instead, they present black vertical slabs, the same type of the stone that covers the floor and gives shape to the steps of the portico. However, the building displays one of the most important uses of blue glazed tiles in Aalto's work. Aalto's option to apply tiles is remarkable considering the different seasons that strongly mark the aesthetics of the building. The architectural discourse of Seinäjoki differs deeply from Spring to Summer to Autumn and the winter time is particularly interesting. The lack of light is strongly compensated by high snow reflection and the blue tiles discuss a life independent of shape constructors, as colour is given.

Snow is not only white but «whites» due how it is perceived regarding light intensity and direction. Also, the properties of snow in relation to the melting phenomenon *versus* frozen glazed surface making, temperature of snow fall, wind, topography and the physical objects snow actually covers streets, squares, lakes, different types of trees, bushes and so on. Physical objects have different shapes and colours to which mass and white is added. This is the most complex aspect to make clear by a written description, but a few aspects can be explained in Seinäjoki. In winter, the white around the building gives the black ground stone of the portico particular detail.



Figs. 14, 15: Alvar Aalto. Seinäjoki Town Hall, 1959-1965.

The steps of the entrance portico are outlined like slabs superimposed one on the other. And the same stone gives scale to the columns. And thus, the black stone of the column gives place to glazed tiles as soon as we enter the building. Thus, there is a certain equivalence between the materiality of stone and the materiality of the glazed tiles. Besides the stone introduces a major argument of the glazed tiles that, in fact, are three-dimensional as in a strong high relief.



Figs. 16, 17, 18: Alvar Aalto. Seinäjoki Town Hall, 1959-1965.

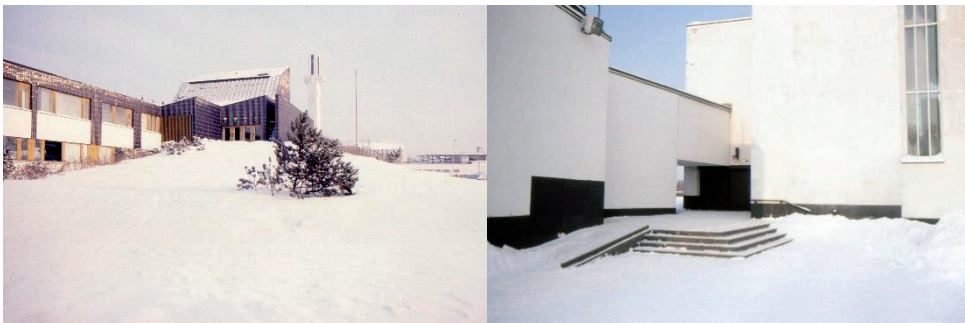


Fig. 19: Alvar Aalto. Seinäjoki Town Hall, 1959-1965.

Fig. 20: Alvar Aalto. Seinäjoki Church, 1958-1960, and Parish facilities and vicarage, 1964-1966.

Aalto's establishes several relationships through the four buildings and the overall strategy is used in each building itself. For instance, the black stone versus snow is used on the other side of the street around the church creating porticos and passages: promenades.



Figs. 21, 22: Alvar Aalto. Seinäjoki Town Hall, 1959-1965.

Yet, we may not forget that, from a distance, this vestibule holds the main volume so characteristic to the building, its iconic shape, that is entirely covered with the blue glazed tiles. From a distance it is a pure vibrant dynamic light surface. And yet, the fact that some type of glazed tiles comes so close to us through our experience of the inner intimate space of the building, certainly gives us another type of aesthetic experience of the glazed tiles.



Figs. 21, 22: Alvar Aalto. Seinäjoki Town Hall, 1959-1965.

The brick-like tiles of the House of Culture in Helsinki, 1955-58

Aalto's Experimental House in Muuratsalo (1953) is a phenomenal exercise of brick-glazed tiles discourse that the architectural discourse may embody. Under cubist *collage-like-aesthetics*, the composition informs about how deep the exploration of the duality between tectonics of the massive wall and surface finishing was. It is a play of appearances and meanings, the territory of the *pure* aesthetic that we find in many of his buildings and the House of Culture in Helsinki is one of them.

The originality of the brick of the House of Culture has often been discussed. Its geometry makes both a flat surface and a curved surface possible. The strong textures combined with the way they construct surfaces gives them a particular three-dimensional expressionist character. Thus, there is a contrast to the plastered surfaces and also to a kind of intermediate solution found at the rear of the building where bricks are painted white giving them a different textured white expression where the bricks are perceived, nonetheless. However, these bricks are different, they look like the common structural bricks and this is the reason why the white cladding is more impressive giving them a metamorphosis into a white textured surface.



Figs. 23, 24: Alvar Aalto. Experimental House, Muuratsalo, 1953.

The new glazed-like surface: plexiglass

The term 'plastic' may seem highly outrageous to an architect whose oeuvre is regarded worldwide as nature based but that idea might not be the most suitable to approach his work on many

ways and much remains to be studied. The problem starts with the fact that there are regular shapes in nature. From the cell to the crystal, to the geometry of the sun flower, although these are geometric shapes found in nature, these shapes are not the shapes of the topography that is built on. Besides, it is strange that a regular form of nature whose development across millions of years of functional selection suddenly becomes efficient to solve the problems of living, such as defining rooms and the shapes of openings.

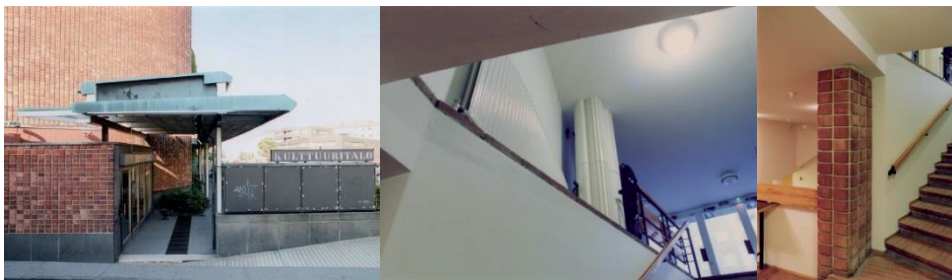
This problem takes us back to the classic. In fact, the reading of Aalto's work from the *natura naturata* tries to explain that there is a relation of the *summa rerum* versus *origo rerum* that is not found in the work of other architects, but it is found in his work. And thus, it would be a perfect fulfilment of the classic in a kind of overwhelming approach beyond rationality. Indeed, there is the myth and the reality.



Figs. 25, 26: Alvar Aalto. House of Culture, Helsinki, 1955-58.

When Kari Jormakka analysed the case of Sunila he noticed that “*The fan pattern is not determined by topography, despite its symbolically ‘natural’ appearance in contrast to the strict rectangular grid of the factory. Rather, both parts in Aalto’s design are equally independent of natural landscape and actually respond more to each other than to anything else. The module of the houses is used in the negative to organize the factory layout: the width of the houses corresponds to the voids between the factory buildings.*”⁴ And yet he proceeds by finding classical roots in the approach “*in the Nolli map depiction of Rome where in the center, the small white spaces are open courtyards, while on the outskirts of town, the small black spaces represent the solids of the villas.*”⁵

Aalto explored extensively the *geometrico-mathematization* of buildings and combined it with tectonics and with the appearance of materiality. Therefore, the problem of *mimesis* has to be a historical problem among many, not one to be followed in a special way and especially not one that could restrict the freedom of poetic creation, of architectural discourse. Thus, the unique plexiglass column is a very special element at ground level in the lobby to the cellar auditorium.



Figs. 27, 28, 29: Alvar Aalto. House of Culture, Helsinki, 1955-58. Entrance to the secondary auditorium (view from west), vestibule at the ground floor and “column” with brick-like-tiles at the ladder.

There seems to be no doubt that recalls the pure glazed element. The opaque white has a shape very similar to the Savoy vase and the high quality of the material means different reflections and light-shadow play. Perhaps this is the white poetic Ultima Thule of the White snow-ice as Aalto saw it!

Glass stories: art and nature

Aalto's glazed tiles wouldn't have been possible without the emergence of the new Finnish artistic glass that comprises a whole approach to glass materiality and colour from craftsmanship, to design, to sculpture. This is a tradition that was renovated along with the development of Modern Architecture and deserves attention. This is an artistic environment where artist met, architects, designers and sculptors certainly worked on ideas of glass and ceramics expression that mingled intricately.

In 1993-1994, Finnish glass made a symbolic journey across Europe and in particular representative works were displayed in the cities of Porto and Lisbon, at the National Museum Soares dos Reis (18.09-10.10.93) and at the National Tile Museum in Lisbon. Twenty-seven artists were represented, Alvar Aalto (1898-1976), Aino Marsio-Aalto (1894-1949), Brita Flander (*1957), Kaj Frank (1911-1989), Görand Hongell (1902-1973), Heikki Kallio (1948-1993), Mikko Karppanen (*1955), Valto Kokko (1933-2017), Mikko Merikallio (*1942), Tiina Nordström (*1957), Kerttu Nurminen (*1943), Gunnel Nyman (1909-1948), Heikki Orvola (*1943), Markku Salo (*1954), Timo Sarpaneva (1926-2006), Taru Syrjänen (*1953), Inkeri Toikka (1931-2009), Oiva Toikka (*1931), Vesa Varrela (*1957), Jorma Vennola (*1943) and Tapio Wirkkala (1915-1985). The work of Björn Weckström (*1935) was not shown among the other artists.

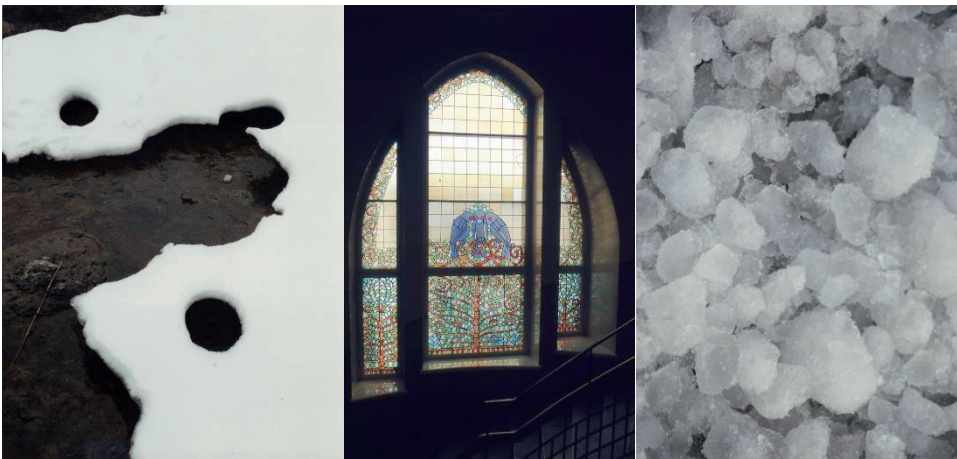


Fig. 30: Melting snow-ice at the lake shore. Early spring. Pyhäjärvi, Tampere.

Fig. 31: Herman Gesellius, Armas Lindgren and Eliel Saarinen Eliel Saarinen. Pohjola insurance company building, Helsinki, 1899-1903.

Fig. 32: Floating broken glass at the Helsinki harbour

Actually, the *new* tradition of Finnish glass came along with ceramics and new porcelain design and some of these artists worked in ceramic art and design, too. In this context, we may note that Aalto glazed tiles were porcelain and long lasting and resistant to thermal amplitude where we may find winter -40° Celcius in contrast with summer $+30^{\circ}$ Celcius. Thus, they have not shown

the pathologies that the Carrara marble carries through the years at the Finlandia Hall, in Helsinki (1962-1975).

Few years earlier, in 1986-1987, in Savonlinna, the Retretti Art Centre devoted special attention to Finnish glass, to sculpture. Björn Weckström (1986) and Timmo Sarpaneva (1987) represented unique opportunities to be acquainted with glass sculptures and with its impressive varieties of expressions, from broken glass to melted glass, from clear glass to coloured transparent glass, from transparent glass to opaque glass, and to the dialogue between glass and stone. In this sense, the site presented a strong argument due to the stone, and the artificial caves where the special atmosphere to be crossed by the poetic light that was able to give life to the works.

Perhaps, what could be exaggerated regarding the duality of Aalto's work and mimesis might not be under stressed regarding, for instance Timmo Sarpaneva's work. To experience of nature, say the frozen lake through winter and spring gives us different notions of ice and snow, different appearances of white and clear or white ice. When all water of atmosphere becomes snow and the lake surfaces freeze, the liquid water continuously flows under and follows the streams of gravity and thus the upper level of the water goes down and the ice goes down, too, otherwise it would lack its support. Yet, this phenomenon is seen only in the shore where we may see the broken glass, its layered crystalline structure showing different types of ice, different colours whose genesis is its original formation that can be the direct water or, rather, different types of snow, different layers that come from those types of snow from successive melting-frozen layers. The solid ice, the one which has a massive glass appearance is created when temperatures fall abruptly from a few degrees over zero to -10°C , -20°C .



Fig. 33: Timmo Sarpaneva. Sculpture at the Retretti Art Centre, 1987.

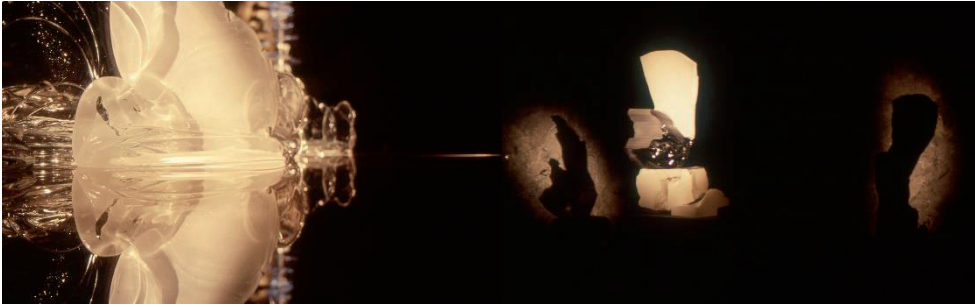


Fig. 34: Timmo Sarpaneva. Sculpture at the Retretti Art Centre, 1987.

Fig. 35: Timmo Sarpaneva. Sculpture at the Retretti Art Centre, 1987. Pierced by the Sun's Shaft, 1987. Sculpture in clear and white glass and granite, 60x55x50cm (hxwxd), today at the House of Tampere Concert Hall.

The glass design of Aino Marsio and Alvar Aalto are references to Finnish Modern Design and, indeed, there is a glass tradition in Finland. Iittala and Muurla symbolise the exploration of craftsmanship and creativity in glass art. Their designs have explored an expression on the glass that takes us to the ice itself, to its crystalline structure, to the different ways ice appears in nature throughout the year. From the clear glass to the white glass much of their aesthetic qualities resemble the experience of the ice in nature, the snow-ice experience.



Figs. 36, 37: Timmo Sarpaneva. Sculpture at the Retretti Art Centre, 1987.

However, it was in sculpture that the glazed object is explored. From its inner structure to the changeable character of the surface the sculpture object does not need to pursue an end like the design object does and therefore the exploration of pure expression falls into a degree of higher liberty. Perhaps, the Finnish approach to glass is the ultimate-intimate approach to the the Ultima Thule.



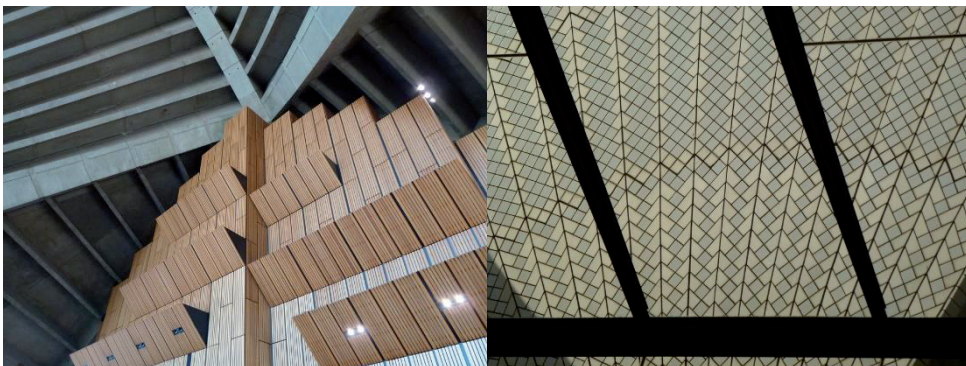
Figs. 38, 39: Tampere, Näsijärvi. Lake shore.

THE SYDNEY OPERA HOUSE: A FINNISH DREAM?

Jørn Utzon architecture is certainly one of the revelations of Scandinavian Modern Architecture and distinct from that of Aalto. Yet, we may remark on a certain hidden gesture of the classical in the Sydney Opera House (1956-1973). György Doczi has made an analysis of the Sydney Opera House showing a modulation based on the golden section and on the $\sqrt{5}$ and thus its sails have been worked upon some *geometrico-mathematical* base so keen to the moderns to whom the order of geometry was both certainty and a historical testimony to be recreated afresh.⁶ Thus, we may reflect on how far Nordic classicism was a source of rationality and poetics, of freedom and innovation.

The inner spaces oppose the magnificent concrete structure to the wood that defines objects in space like in the huge vestibule of the concert hall, reflects a specific Scandinavian signature where wood brings the huge scale into a more comfortable scale of the individual, that is a humanization of the architectural space. But, the most iconic images came from the outside, from the harbour view, from the shore or from the many boats that cross the water.

Surface technology has its own place in the history of mankind up to the present technology of surface mechanics. Glass-ceramics is one of those surface technologies. In Finland, the rise of Modern industry, namely the Arabia Factory, was a highlight that rooted that tradition to new design. Yet, tile technology was strongly developed, and the design of the Sydney Opera House challenged materiality and a solution for the finishing of the curved-like-sail surfaces, and glazed tiles were the answer.



Figs. 40, 41: Jørn Utzon. Sydney Opera House, 1956-1973.

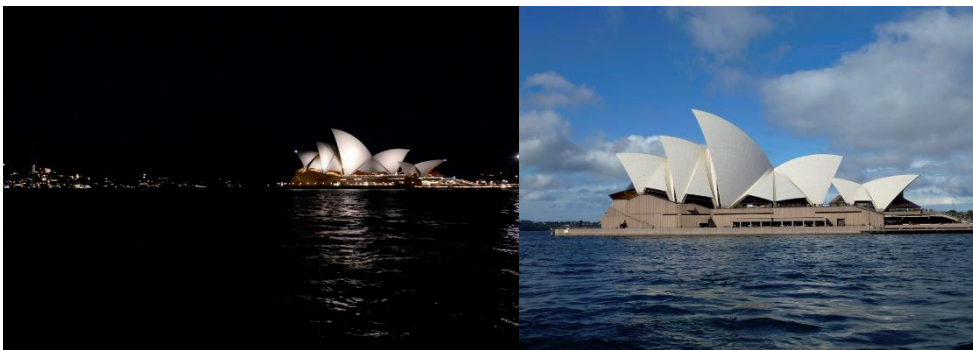
The Sydney Opera House tiles were manufactured by the Swedish Partek Höganäs company which had important development in Finland in the 1970's and 1980's. In the late 1980's, as one would be invited to the company headquarters in Helsinki, we could be acquainted to the fact that the company was proud of those tiles that were created, developed and manufactured for the Sydney Opera House only. State-of-the-art surface coating was required and the company planned to develop this technology for mass produced tiles.



Figs. 42, 43: Jørn Utzon. Sydney Opera House, 1956-1973.

The tile composition radiates from two colours and two finished coatings. As they are seen from distance all tiles look white, but they are a perfect articulation of two colours, white and cream. Besides, they are matt and glazed. Thus, the basic diamond shape is illuminated and gives the Sydney Opera House a sparkling result that provides a rich aesthetic experience throughout the day and night, and all the year.

We could say that the Sydney Opera House tiles in many ways, represent the creativity of Scandinavia art, design and technology and their ability to be brought into architecture by the philosophy of the Industrial Arts. We may not forget the central rule that Taideteollinen Korkeakoulu performed on the cultural and industrial development of Finland. Similarly, other Scandinavian countries founded institutions or study programmes. The university was regarded by the Finns as the University of Industrial Arts and was later renamed University of Art and Design Helsinki and today it is part of the Aalto University.



Figs. 44, 45: Jørn Utzon. Sydney Opera House, 1956-1973.

Culturally, to the Finns, all development from the craftsmanship to the industrial through the aesthetic was synonymous with Finnish *sisu* that can be translated as perseverance, but *never-*

ending-perseverance could be a better translation. If one aims at a complete and comprehensive story that may bring craftsmanship to state-of-the-art technology, glazed tiles are certainly at the core of such story and Aino-Marsio and Alvar Aalto are certainly privileged actors. Aalto's oeuvre also takes us to the debate of the role of classicism in Modern Architecture. The representation of the apeiron – *ἄπειρον* – in Aalto's columns synthesize an ancient *tempo* former to the classical where the intellectual work and craftsmanship were not two distinct ideas. Perhaps, there were many ways of inquiring into history, but the heuristic exploration of bricks and glazed tiles held by Aino-Marsio and Alvar Aalto was certainly remarkable and needs further exploration.

Acknowledgments

This work is financed by Nacional Funds by FCT, the Portuguese national funding for science, research and technology, I.P, under the Project UID/AUR/04026/2013.

Notes

¹ PALLADIO, Andrea – *The Four Books of Architecture*. Dover Publications, Inc., New York, 1965. Bk. I, Chap. XXV.

² SUMMERSON, John – *The Classical Language of Architecture*. Thames and Hudson, London, 1988, p. 13.

³ Ibid., p. 18.

⁴ JORMAKKA, Kari; GARGUS, Jacqueline; GRAF, Douglas – *The Use and Abuse of Paper. Essays on Alvar Aalto*. Datutop 20. Tampere University of Technology, Tampere, 1999, p. 88.

⁵ Ibid.

⁶ HARGITTAI, István (ed.): *Symmetry, Unifying Human Understanding*. Pergamon Press, New York, 1986, p. 47-50.

Bibliographic references

DONNELLY, Marian C. – *Architecture in the Scandinavian Countries*. The MIT Press, Cambridge, Massachusetts, 1992.

GIEDION, Sigfried: *Space, Time and Architecture. The growth of a new tradition*. Harvard University Press, Cambridge (Mass.), 1995.

HAHN, Robert – *Anaximander and the Architects. The Contributions of Egyptian and Greek Architectural Technologies to the Origins of Greek Philosophy*. State University of New York Press. New York, 2001.

MARTIN, Roland – *History of World Architecture. Greek Architecture*. Electa. Milano, 2003.

MILLER, Arthur I. – *Einstein, Picasso. Space, Time and the Beauty that Causes Havoc*. Basic Books, New York, 2001.

MÄKIKALLI, Maija; TERHO, Henri (ed.) – *Alvar Aalto – Villa Tammekann*. Centre for Cooperation of the Universities of Turku and Tartu. The University of Turku. Turku, 2000.

PUENTE, Moisés – *Pavilhões de Exposição. 100 Anos*. Editorial Gustavo Gili, S.A., Barcelona, 1980.

POPPER, Karl – *The World of Parmenides. Essays on the Presocratic Enlightenment*. Edited by Arne F. Petersen with the assistance of Jørgen Mejer. Routledge. London and New York, 2002.

SCHILD, Göran – *Alvar Aalto. A Life's work. Architecture, Design and Art*. Otava, Helsinki, 1994.

- SCHILDT, Göran (ed.) – *Alvar Aalto in his own words*. Otava, Helsinki, 1997.
SCHILDT, Göran – *Alvar Aalto: The Early Years*. Rizzoli, New York, 1984.
SCHILDT, Göran – *Alvar Aalto: The Decisive Years*. Rizzoli, New York, 1986.
SCHILDT, Göran – *Alvar Aalto: The Mature Years*. Rizzoli, New York, 1989.

Photographic credits references

All photographs by the author.

Chemical characterization of the glassy phase in glazes from 17th century majolica azulejos

Augusta Lima

Department of Conservation and Restoration and Research Unit VICARTE – Glass and Ceramics for the Arts, Faculdade de Ciências e Tecnologia, Universidade NOVA de Lisboa, Caparica, Portugal, arl@fct.unl.pt

Mathilda Larsson Coutinho

Research Unit VICARTE – Glass and Ceramics for the Arts, Faculdade de Ciências e Tecnologia, Universidade NOVA de Lisboa, Caparica, Portugal, mathildal@gmail.com

Carlo Pantano

Department of Materials Science and Engineering, Materials Research Institute, The Pennsylvania State University, University Park, PA, USA, cgp1@psu.edu

SUMMARY: In the present study, the chemical compositions of the glassy phase in various glazes from 17th century majolica tiles, or azulejos, are presented. The microstructures of the glazes were also characterized. The glaze samples were collected from a set of twelve azulejos from the National Tile Museum (Museu Nacional do Azulejo), of which ten are attributed to Portuguese production and two have an uncertain provenance; one is seemingly from Portugal or Spain and the other from Flanders or Spain. The chemical analysis was performed by electron probe microanalysis (EPMA) on polished cross-section samples, in regions free of particles and without painting, to avoid contamination by colorants. Results revealed that the glassy phases are lead-alkali silicate glasses with contents of SiO₂ in the range 55-61 wt%, PbO between 20-28 wt% and total alkali (Na₂O + K₂O) contents in the range 7.1-9.2 wt%. The contents of CaO are very low, usually not exceeding 1.5 wt%, whereas the contents of Al₂O₃ are relatively high, in the range 4.4-6.5 wt%, except for the azulejo presumably from Flanders or Spain. The glassy phase of that azulejo contains a much lower content of Al₂O₃ (ca. 2.5 wt%) than those of Portuguese azulejos and the highest content of CaO (ca. 2.5 wt%), which indeed points to a non-Portuguese origin. The glassy phase of the azulejo from Spain or Portugal is comparable to those of Portuguese production. In a general way, the compositions obtained for the glassy phases of Portuguese azulejos show higher contents of SiO₂ and Al₂O₃ and lower contents of CaO than the compositions reported for glazes of Renaissance Italian majolica from Urbino and Pesaro.

KEY-WORDS: azulejos, majolica, glazes, glassy phase, EPMA.

INTRODUCTION

Portuguese 17th century majolica tiles, or *azulejos*, are coated with a white opaque lead-tin glaze typically decorated with in-glaze polychrome patterns. These tin-opacified glazes exhibit a heterogeneous microstructure due to the presence of the opacifying crystals of cassiterite (SnO₂), gas bubbles and a variable amount of crystalline particles dispersed on the glassy phase.

In the present study, the glazes of a set of *azulejos* were analysed in order to determine the chemical composition of the glassy phases. The main goal of this analysis was to obtain the

average composition of the glassy phase of glazes from Portuguese 17th century *azulejos* to be used as reference in the production of a model glass for corrosion studies of this type of glaze. Although initially this analysis was not intended to be an archaeometric study, the composition of the glassy phases may be of interest for provenance studies as it provides information about the base composition of the glazes, thereby contributing to the distinction of production centres and periods. In addition to the chemical characterization, the microstructural features of the glazes were also characterized.

MATERIALS AND METHODS

A set of twelve *azulejos* representative of the different typologies of *azulejos* found in Portugal from the late 16th to the early 18th centuries were selected for analysis (Figure 2.1 and Table 2.1). The tiles were provided by the National Tile Museum (*Museu Nacional do Azulejo*, Portugal) and the glazes were in apparent good condition. Of the twelve *azulejos* analysed, ten are attributed to Portuguese production and two have an uncertain provenance, one is seemingly from Portugal or Spain (PT 01x) and the other from Flanders or Spain (SCT 38).



Figure 2.1: *Azulejos* from the collection of the National Tile Museum selected for the analysis of the glazes glassy phase by EPMA.

Table 2.1: Description of the *azulejos* selected for the glazes glassy phase analysis.

Ref. <i>azulejo</i>	Date (AD)	Provenance	Colours of painting
PT 01x	1590-1615	Portugal or Spain	blue and yellow
PT 10	1620-1660	Portugal	blue and yellow
PT 11	1620-1640	Portugal	blue and yellow
PT 40	1700-1720	Portugal	blue
PT C01	c. 1720	Portugal	blue and purple
SCT 07	1630-1640	Portugal	blue and orange
SCT 08	1620-1660	Portugal	blue, yellow and orange
SCT 13	1650-1670	Portugal	blue, yellow, orange and olive-green
SCT 15	1630-1640	Portugal	blue and yellow
SCT 20	1660-1680	Portugal	blue and yellow
SCT 29	1650-1670	Portugal	blue, yellow, emerald-green and dark brown
SCT 38	1590-1610	Flanders or Spain	blue, orange and yellow

Small samples of the glazes of a few mm² were dry cut with a diamond saw, further embedded in cross-section in epoxy resin (Araldite® 2020) and polished with abrasive and Micro-Mesh® papers down to 12000 grit (2 µm).

All samples were observed by reflected light optical microscopy (OM) using an Axioplan 2® Zeiss microscope equipped with an incident halogen light illuminator (tungsten light source, HAL 100) and a digital Nikon camera DXM1200F, with Nikon ACT-1 application program software for photomicrographs.

The chemical composition of the glazes glassy phase was determined by electron probe microanalysis (EPMA) using a Jeol JXA-8500F at the *Laboratório Nacional de Energia e Geologia* (National Laboratory of Energy and Geology) equipped with five wavelength-dispersive spectrometers (PET, LiF, TAP and LDE1 crystals). The operating conditions used were: accelerating potential 15 kV, beam current 10 nA (major and minor components). An 8-10 µm diameter electron beam and limited counting time (10 s for major and minor elements, 20 to 30 s for trace elements) was used. The samples were carbon coated prior to analysis. Seventeen elements were quantified: X-ray K α lines were analysed except for lead (M α lines) and tin and barium (L α lines). The net X-ray intensities (peak minus background) were quantified by means of PAP correction programs supplied by Jeol. A ~50µm x 50µm area, free of silica or feldspar particles, was scanned.

To verify the accuracy of the method, reference glasses of known composition (Corning C and D) were analysed under the same experimental conditions as for the samples. The calculated concentration values showed accuracy better than 3% for the major element oxides (≥ 1 wt%) and better than 25% for the minor element oxides (≤ 1 wt%). The EPMA settings used in this study allow most of the oxides to be analysed in concentrations as low as 0.02-0.05 wt%.

RESULTS AND DISCUSSION

Microstructure

The optical microscopy analysis revealed only one glaze layer - the white opaque - in all *azulejos*. The average thickness of the glazes varied from 250 to 800 μm . When observed in polished cross-section, the yellow, orange and dark brown colours were found to consist of a well-defined layer at the glaze surface composed by the pigment particles (Figure 3.1 (a) and (b)). In the *azulejos* PT 10, SCT 08, SCT 15 and SCT 20, the blue colour also forms a distinct layer, but in this case with none or very few particles, thus it is transparent. Nevertheless, some diffusion of the blue colour into the white region can be observed (Figure 3.1 (c)). The green colorant is very well dissolved in the glaze glassy phase, staining the glaze section throughout (Figure 3.1 (d)).

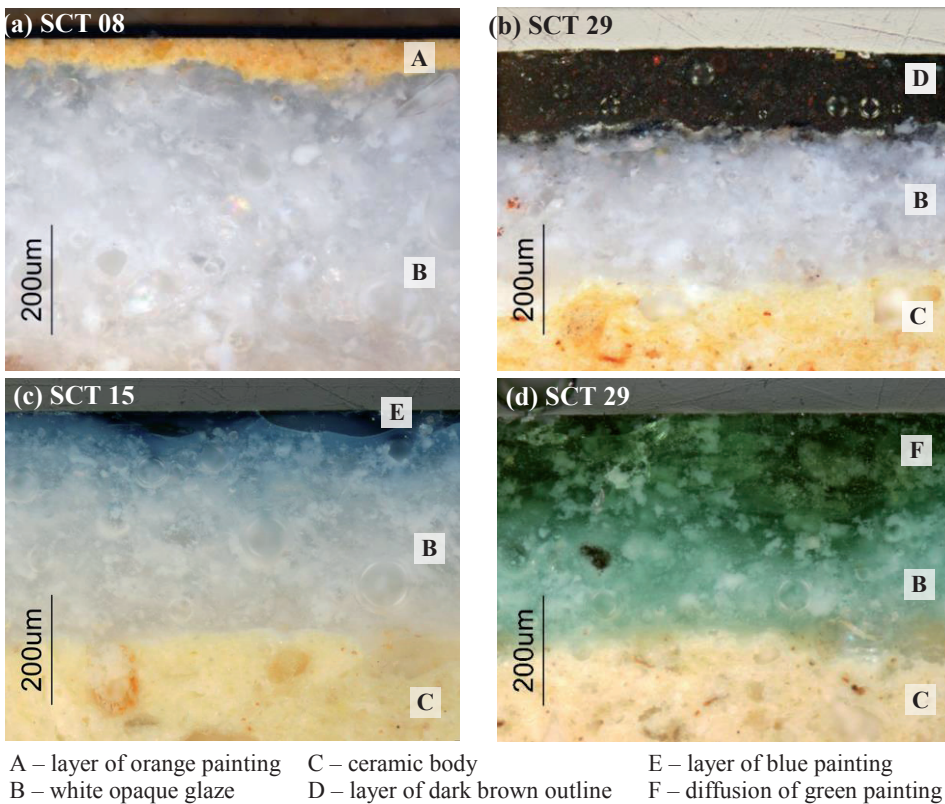


Figure 3.1: Photomicrographs of polished cross-section samples of the studied *azulejos* obtained by OM: (a) area with orange painting of *azulejo* SCT 08, showing a well-defined layer of yellow and red particles at the glaze surface; (b) area with dark brown outline of *azulejo* SCT 29, showing a thick and uniform layer of purple and red particles on top of the white glaze; (c) area with blue painting of *azulejo* SCT 15, showing a transparent blue layer at the glaze surface; (d) area with green painting of *azulejo* SCT 29, showing the diffusion of the green colour through the glaze section.

The photomicrographs obtained from the EPMA analysis showed that in some *azulejos* the blue layer is free of particles, whereas in other samples it contains very fine crystals ($< 2 \mu\text{m}$) uniformly dispersed (Figure 3.2). In the white areas of the glazes, a heterogeneous microstructure can be distinguished showing large bubbles, angular crystalline particles and agglomerates of fine crystals of cassiterite distributed in the glassy phase (Figure 3.2 (b) and (e)). A previous study of the *azulejos* with the reference “SCT” has shown that the angular crystalline particles consist mainly of quartz and K-feldspars [1].

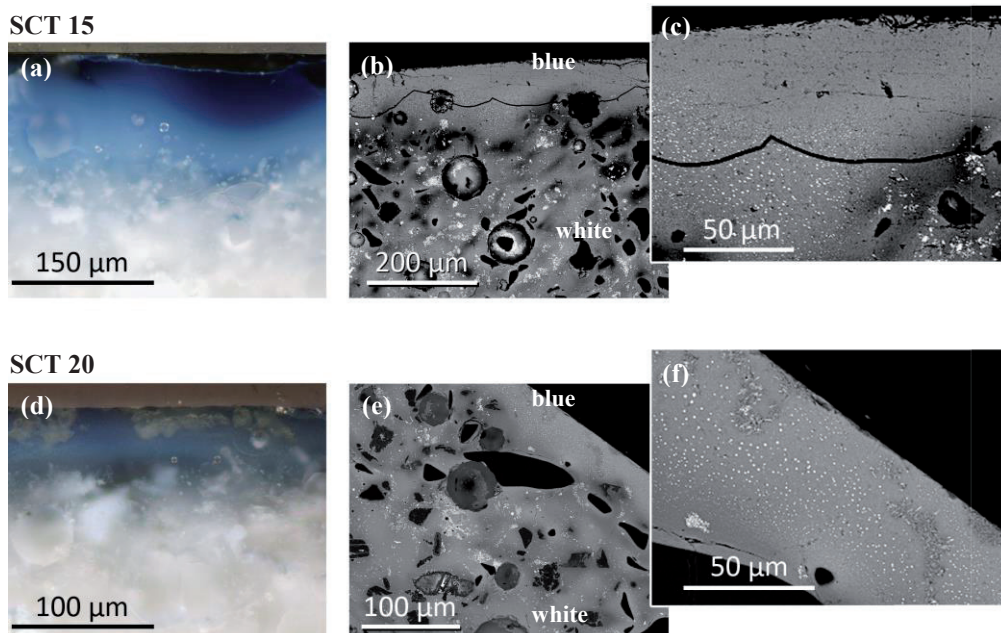


Figure 3.2: Photomicrographs of polished cross-sections of the glazes of *azulejos* SCT 15 and SCT 20, acquired in an area with blue painting: (a) and (d) transparent blue layer at the glaze surface (OM); (b) and (e) EPMA photomicrographs showing the blue layers free of large crystals and the heterogeneous microstructure of the white opaque glazes, containing large bubbles, angular crystals of quartz and K-feldspar (black) and clusters of fine cassiterite crystals (white); (c) and (f) detail of the blue layers, showing the presence of fine particles ($< 2 \mu\text{m}$) uniformly dispersed.

The OM and EPMA observations obtained in this study are consistent with the microstructural features reported by other studies on Portuguese *azulejos* [1-3].

Chemical composition

The chemical compositions of the glazes glassy phases are reported in Table 3.2. As expected, the glassy phases are lead-alkali silicate glasses with the SiO_2 contents in the range 55-61 wt%, PbO between 20-28 wt% and total alkali ($\text{Na}_2\text{O} + \text{K}_2\text{O}$) contents in the range 7.1-9.2 wt%. The contents of CaO are low (0.3-2.6 wt%) whereas the contents of Al_2O_3 are relatively high (4.4-6.5 wt%), except for *azulejo* SCT 38.

In Table 3.1 is reported the average composition of the main oxides found in the glassy phases of the glazes from Portuguese *azulejos* in comparison to the contents obtained for the *azulejos* PT 01x and SCT 38; ie, those of uncertain provenance. As can be seen by the low standard

deviation values, the contents of the main oxides in the glassy phases of Portuguese *azulejos* are similar, except for the content of CaO, which presents a slightly higher variation.

The glassy phase of *azulejo* SCT 38, which is presumably from Flanders or Spain, contains a much lower content of Al₂O₃ and a higher content of CaO than those of Portuguese production (Figure 3.3 and Table 3.1). This significant difference in the contents of Al₂O₃ and CaO indeed points to a non-Portuguese origin. However, it should be stressed that these differences may result not from “local” recipe but rather from the composition of the ceramic body, as Al and Ca may derive from the digestion of the body by the glaze during firing. On the other hand, the glassy phase of the *azulejo* PT 01x, from Spain or Portugal, is comparable to those of Portuguese production.

Table 3.1: Average content of the main oxides in the glassy phases of the glazes of *azulejos* attributed to Portuguese production in comparison with the contents obtained for the glassy phase of *azulejos* PT 01x and SCT 38.

Glassy phase		Na ₂ O	Al ₂ O ₃	SiO ₂	K ₂ O	CaO	PbO
In the glazes of Portuguese <i>azulejos</i> (average, n=10)	wt %	2.98	5.49	58.9	4.96	1.02	23.0
	σ	0.44	0.69	1.7	0.84	0.54	1.8
In the glaze of <i>azulejo</i> PT 01X	wt %	2.32	5.28	58.8	5.81	0.70	23.3
In the glaze of <i>azulejo</i> SCT 38	wt %	2.70	2.37	58.5	4.46	2.64	25.6

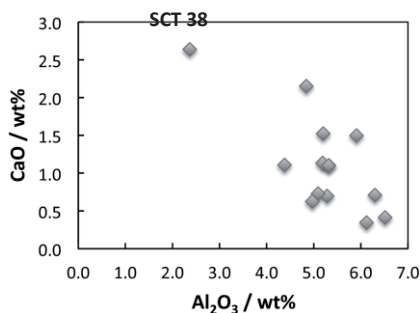


Figure 3.3: Bivariate plot of CaO versus Al₂O₃ content measured in the glassy phases of the glazes from the *azulejos* provided by MNAz, dating from late 16th to early 18th centuries.

Comparison of the compositions of the glassy phases in glazes of 17th century Portuguese *azulejos* with data from studies on Italian majolica revealed that, in a general way, the glassy phases of Portuguese *azulejos* contain higher contents of SiO₂ and Al₂O₃ and lower contents of CaO than the compositions reported for the glassy phases in glazes of Renaissance Italian majolica from Urbino and Pesaro [4-5].

Table 3.2: Average chemical composition, and corresponding standard deviation, of the glassy phases of the lead-tin glazes from the late 16th to the early 18th centuries *azulejos* provided by EPMA (in wt%, analyses normalized to 100%, n ≥ 3).

Ref. <i>azulejo</i>	Na ₂ O	MgO	Al ₂ O ₃	SiO ₂	P ₂ O ₅	Cl	K ₂ O	CaO	TiO ₂	MnO	Fe ₂ O ₃	CoO	CuO	ZnO	SnO ₂	BaO	PbO
PT 01x	2.32	0.36	5.28	58.8	5.81	0.43	5.81	0.7	0.36	bd	0.45	0.06	bd	nd	1.71	0.14	23.3
σ	0.09	0.08	0.8	0.9	0.42	0.03	0.42	0.13	0.13		0.17	0.01			1.21	0.1	2.1
PT 10	3.26	0.73	6.3	59.6	4.36	0.32	4.36	0.71	0.26	bd	0.57	0.06	bd	0.18	0.69	0.09	22.6
σ	0.24	0.29	1.1	2.4	0.35	0.06	0.35	0.1	0.1		0.31	0.01		0.16	0.14	0.07	2
PT 11	2.51	0.52	5.91	56.9	5.27	0.12	5.27	1.5	0.31	0.1	0.59	0.06	0.14	nd	1.77	0.08	23.8
σ	0.11	0.12	1.16	1.3	0.49	0.04	0.49	0.68	0.12	0.06	0.18	0.04	0.08		1.29	0.05	1.7
PT 40	2.78	0.17	6.12	59.6	4.98	0.29	4.98	0.34	0.3	nd	0.54	bd	bd	0.13	1.09	0.14	23.5
σ	0.11	0.07	0.86	0.9	0.34	0.03	0.34	0.1	0.04		0.11			0.1	0.33	0.09	0.7
PT C01	3.29	0.63	5.32	60.6	4.79	0.45	4.79	1.1	0.17	0.05	0.48	bd	0.07	0.24	1.88	0.12	20.8
σ	0.19	0.14	1.48	1.6	0.76	0.05	0.76	0.13	0.09	0.01	0.18		0.01	0.18	1.45	0.07	2
SCT 07	3.39	0.14	6.51	58.8	4.77	0.36	4.77	0.41	0.33	bd	0.51	0.07	bd	0.24	1.3	0.11	22.9
σ	0.17	0.05	0.82	1.3	0.62	0.03	0.62	0.17	0.08		0.06	0.03		0.17	0.63	0.04	3.2
SCT 08	3.27	0.73	5.19	61.1	4.36	0.46	4.36	1.13	0.17	nd	0.32	bd	0.12	0.32	0.9	0.26	21.3
σ	0.23	0.07	0.52	1.2	0.32	0.07	0.32	0.34	0.07		0.23		0.01	0.06	0.16	0.17	1.6
SCT 13	3.32	0.71	4.97	56.8	3.74	0.58	3.74	0.62	0.14	0.06	0.57	0.1	nd	0.27	0.87	0.12	26.9
σ	0.2	0.08	0.39	1.1	0.39	0.01	0.39	0.03	0.04	0.03	0.33	0.04		0.22	0.23	0.01	1
SCT 15	2.22	0.82	4.38	59	5.83	0.41	5.83	1.11	0.2	nd	0.63	bd	0.05	0.36	1.27	0.08	23.4
σ	0.14	0.17	0.88	0.8	0.46	0.1	0.46	0.42	0.06		0.09		0.01	0	0.32	0.04	1.9
SCT 20	2.45	0.67	4.84	56.3	6.74	0.22	6.74	2.15	0.3	nd	0.89	bd	0.06	0.17	0.82	0.06	24.1
σ	0.21	0.39	1.17	1.4	0.47	0.03	0.47	0.93	1.02		0.76		0.02	0.03	0.19	0.01	1.2
SCT 29	3.28	0.63	5.32	60.6	4.79	0.44	4.79	1.1	0.3	bd	0.48	bd	bd	0.24	1.89	0.12	20.7
σ	0.19	0.15	1.41	0.9	0.71	0.05	0.71	0.13	0.14		0.17			0.18	1.48	0.07	2.1
SCT 38	2.7	0.6	2.37	58.5	4.46	0.12	4.46	2.64	0.24	nd	0.64	0.05	bd	nd	1.74	0.18	25.6
σ	0.21	0.18	0.09	1.6	0.71	0.05	0.71	0.72	0.11		0.21	0.01		0.51	0.06	0.06	2.5

bd: below detection limit; nd: not detected

CONCLUSIONS

In the present study, the glassy phase in glazes of *azulejos* used in Portugal in the 17th century was chemically characterized. Although the main objective of this study was not the characterization of production centres or determination of manufacturing provenance, the chemical analyses of the glazes glassy phase revealed distinguishing features of the *azulejos* of Portuguese production relative to one *azulejo* presumably manufactured in Flanders or Spain. The glassy phases in the glazes of Portuguese *azulejos* are lead-alkali silicate glasses with similar contents of Na₂O, Al₂O₃, SiO₂, K₂O, and PbO. The contents of CaO presented a greater variation, ranging from 0.3-2.1 wt%, even so these contents are lower than those usually measured in the glassy phase of glazes of Renaissance Italian majolica from Urbino and Pesaro. On the contrary, in a general way, the contents of SiO₂ and Al₂O₃ in the glassy phases of Portuguese *azulejos* are higher to those reported for Italian majolica.

The *azulejo* presumably manufactured in Flanders or Spain has a distinct composition from the remaining *azulejos*, presenting a higher content of CaO (2.64 wt%) and a significantly lower content of Al₂O₃ (2.37 wt%) than the average content found in the glassy phases of Portuguese *azulejos* (1.02 wt% and 5.49 wt%, respectively). This difference in composition suggests a non-Portuguese origin.

Other *azulejo* of uncertain provenance, presumably of Portuguese or Spanish production, has a composition comparable to those of Portuguese production.

For further conclusions on the manufacturing provenance of these *azulejos*, a more detailed analysis of glazes (trace elements, microstructural features and the identification of the crystalline particles) and ceramic body (chemical and mineralogical composition as well as textural features) would be needed. The assignment to a specific manufacturing provenance is only possible if the production centres of glazed ceramic tiles are well characterized. At the present the studies focusing on the characterization of the 17th century manufacturing centers of glazed tiles are scarce.

Acknowledgements

The authors are grateful to Doutora Maria Antónia Pinto de Matos and Alexandre Nobre Pais, from *Museu Nacional do Azulejo*, for kindly providing the studied *azulejos* and their historical data. The authors are also thankful to João Mimoso, from *Laboratório Nacional de Engenharia Civil*, for support on the selection of the *azulejos* and fruitful discussions, and to Fernanda Guimarães from *Laboratório Nacional de Engenharia Geológica*, for the EPMA analysis. We are also grateful to Marco Verità, from *Laboratorio di Analisi dei Materiali Antichi LAMA — IUAV University*, for the valuable comments.

This study was supported by *Fundação para a Ciência e a Tecnologia* (FCT) under the PhD grant SFRH/BD/44527/2008 and Vicarte - UID/EAT/00729/2013.

Bibliographic references

- [1] COENTRO, S., MIMOSO, J. M., LIMA, A. M., SILVA, A. S., PAIS, A. N., & MURALHA, V. S. F. - *Multi-analytical identification of pigments and pigment mixtures used in 17th century Portuguese azulejos*. Journal of the European Ceramic Society, 32(1), 2012, 37-48.
- [2] COROADO, J., & GOMES, C. (2005). *Physico-chemical characterization of ceramic glazed wall tiles dated of the 17th century, from the "Convento de Cristo", in Tomar, Portugal*. In Proc. 7th European Meeting on Ancient Ceramics (EMAC'03): Understanding people through their pottery, Lisbon,

- October 27-31, 2003, M. I. Prudêncio, M. I. Dias & J. C. Waerenborgh (Eds.), *Trabalhos de Arqueologia*, 42, 33-39, 2003, Lisboa, Instituto Português de Arqueologia.
- [3] MIMOSO, J. M., & ESTEVES, L. - *Uma sistematização do destacamento do vidro em azulejos*. *Conservar Património*, 23, 2016, 9-14.
- [4] ANTONELLI, F., ERMETI, A. L., LAZZARINI, L., VERITÀ, M., & RAFFAELLI, G. - *An Archaeometric Contribution to the Characterization of Renaissance Maiolica from Urbino and a Comparison with Coeval Maiolica from Pesaro (the Marches, Central Italy)*. *Archaeometry*, 56(5), 2014, 784-804.
- [5] RICCI, C., MILIANI, C., ROSI, F., BRUNETTI, B. G., & SGAMELLOTTI, A. - *Structural characterization of the glassy phase in majolica glazes by Raman spectroscopy: A comparison between Renaissance samples and replica processed at different temperatures*. *Journal of Non-Crystalline Solids*, 353(11-12), 2007, 1054-1059.

On the use of glaze and ceramic body analytical spectra in heritage azulejos as beacons of provenance

João Manuel Mimoso

Laboratório Nacional de Engenharia Civil, Lisbon, Portugal

Maria Augusta Antunes

Laboratório Nacional de Engenharia Civil, Lisbon, Portugal

Sílvia Pereira

Laboratório Nacional de Engenharia Civil, Laboratório HERCULES - Universidade de Évora, Portugal

António Candeias

Laboratório HERCULES - Universidade de Évora, Évora, Portugal

Alexandre Pais

Museu Nacional do Azulejo, Lisbon, Portugal

SUMMARY: A research group including Museu Nacional do Azulejo (Portuguese National Azulejo Museum), Laboratório Nacional de Engenharia Civil and Laboratório HERCULES of University of Évora joined forces to elucidate the beginnings of the production of faience azulejos in Lisbon during the mid-16th century. During the first part of the study SEM-EDS and XRF spectra were acquired from glazes and ceramic bodies of azulejos sampled from panels, single tiles from the Museum collections and archaeological finds. By comparing spectra obtained on significant areas it is possible to obtain a glimpse of affinity or of dissimilarity pointing to a similar or to a different officinal origin. In many cases such a preliminary approach is very important to orient the selection of cases for more detailed analytical examination. However, for that purpose it is necessary to consider the spectra taking into account the material, for instance considering what may be important and what should best be discarded and why, for the purposes of such a screening. This communication addresses the subject through exemplary cases.

KEY-WORDS: Provenance studies; majolica; archaeometry; tiles, XRF, SEM-EDS.

INTRODUCTION

Studies of provenance of ceramic items or most other heritage specimens usually rely on analytical quantification followed by some form of “objective” decision-making to aggregate clusters of (hopefully) objects with the same provenance. Such studies often produce an impressive array of instrumental results, out of which it is increasingly difficult to make sense, even when the researcher is personally certain that there must be some way to extract a measure of reasonably trustworthy conclusions from the data. Looking for objectivity to base the conclusions the researcher will apply a number of numerical methods some of which stemming from the statistical treatment of the data.

Three methods often encountered are the use of ternary plots, the calculation of Euclidean distances followed by an interpretative visualization through dendrograms and principal component analysis (PCA) or one of its specialized derivatives. In PCA an imaginary space of as many dimensions as one has variables is represented and the quantitative result of each item is

set as a single point in a system of orthonormal axes in that space. Then the mathematical approach will determine a direction in that space onto which the spread of the points will have a maximum extension, and other directions, orthogonal to the first, corresponding to the second, third, etc largest spread. All the points are now projected into a new reference system of axes following those directions and (hopefully) points that might otherwise be near one to the other or even superimposed are now spread well apart making it possible to define clusters (figure 1).

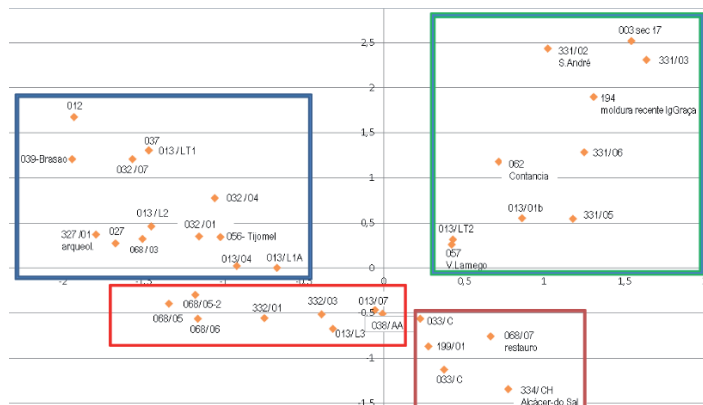


Figure 1: Tentative clustering after a Principal Component Analysis of azulejo ceramic body compositions defined by their contents in seven different chemical elements.

PCA is a powerful and impressive tool and its results can be very elucidative. However, there is a catch in all those methods and it is the same in all statistical decision-making: at some point the researcher is always called to make a subjective decision. Why exclude from a cluster another result very near its limits in the graphical representation? How to know whether a point included in a boundary is not actually an outlier from some other different cluster? Or, in general, what are the critical values of the test statistic that separate the rejection from the non-rejection region?

We are not going to propose a solution ruling away all subjectivity. On the contrary, we shall discuss another subjective approach to help cluster glazed ceramic specimens based solely on spectroscopic spectra but applicable to other analytically complex objects. A compelling feature is that it does not require quantification, resorting directly to the graphical spectra themselves and the subjectivity derives from the need to verify whether the closeness between spectral results is sufficient to grant tentative clustering. In this method special attention should be placed on using the same analytical equipment and the same conditions (e.g. the same acquisition time) to acquire the spectra and used under the same conditions. If conditions differ, they may affect the relative size of peaks and the evenness of the baselines making comparability more difficult.

Glazed ceramics offer at least two different spectra for comparison, those acquired from the glaze and those acquired from the ceramic body. Information from both can be useful to attribute the geographical their provenience. A similarity of ceramic bodies might suggest a same geographical origin and a similarity of glazes might point to the use of a same formulation or workshop.

But spectra are not just graphs in an x-y coordinate system - peaks have a chemical meaning and can be translated into elemental contents if one knows the material and has the means for that second step. In all cases they offer a wealth of information but it is necessary to know how to interpret them and for that it is necessary to have knowledge about the materials, the analytical techniques used, and the counterparts of the analytical results.

In this paper, we discuss the elemental nature of glazes and ceramic bodies and explain their consequences on the approach proposed. Although we have also successfully used this approach with spectra obtained on sites with an energy-dispersive X-ray fluorescence (ED-XRF) portable analyser, we shall exemplify it solely with spectra acquired by scanning-electron microscopy coupled with energy-dispersive spectroscopy (SEM-EDS). The examples pertain to our on-going research with faience azulejos.

THE MATERIAL OF FAIENCE AZULEJOS

The glaze

Faience azulejos (figure 2) are a layered material in which a previously fired ceramic base (the ceramic body) is overlaid by a glass layer eventually painted with pigments able to withstand temperatures of over 1,000 °C and then fired a second time. During this second firing, pigments become encased in the glass, which becomes a glaze by connecting to the ceramic body in a very durable manner, as long as there is a degree of compatibility between them.



Figure 2: Part of an azulejo panel at Igreja da Graça in Lisbon. At the corners where the glaze detached, the underlying cream or reddish ceramic body became visible.

The main components of a tin glaze, traditionally used in faience azulejos, are, by atomic number (Z): sodium (Na, Z=11); magnesium (Mg, Z=12); aluminium (Al, Z=13); silicon (Si, Z=14); phosphorus (P, Z=15); potassium (K, Z=19); calcium (Ca, Z=20); titanium (Ti, Z=22); iron (Fe, Z=26); tin (Sn, Z=50); and lead (Pb, Z=82). Of those, the main elemental components of the glaze are Si (the amorphous glass is formed from silica), Pb (a fusing agent that lowers the fusion temperature of silica from ca. 1900 °C to about one third of that value), and K or Na or both (also fusing agents that are incorporated into the glass structure altering the viscosity of the molten glass and its rate of retraction during the cooling phase). The content in Sn derives from the use of tin oxide as opacifier, turning the otherwise translucent glaze into an opaque white “canvas” over which a decoration may be painted.

Any other elements “found” in the glaze with the average XRF or EDS instruments must be viewed with the utmost caution particularly when one presses a button and accepts flatly an

instrumental quantification. For instance, the presence of sulphur ($K\alpha_1$ 2.309 and $K\beta_1$ 2.465 emission lines) in glazes is usually an artefact resulting from confusion with peaks of lead ($M\alpha_1$ 2.342 and $M\beta_1$ 2.444 emission lines) and there are also a number of mystifying artefact peaks resulting from the elements constituent of the analytical instrument or unavoidable atomic phenomena such as escape and sum peaks. However since the method of directly analysing the spectra profiles is purely comparative, one do not have to be much concerned with recurring misidentifications or repetitive technologic artefacts.

We should have in consideration that from the elements mentioned above, the size of Sn peaks or the resulting quantifications by non-destructive XRF are not to be trusted unless the acquisition area is very considerable. Sn crystals form during firing of the glaze and often aggregate in a manner that, with small measuring areas as imposed by the size of most samples, the acquisition may fall on an area with no Sn at all or, on the contrary, where a high content is concentrated. Sn ($L\alpha_1$ 3.444 and $L\beta_1$ 3.663 emission lines) also interferes with the main peak that should be used to identify Ca ($K\alpha_1$ 3.692 emission line), rendering this element much less valuable in the characterization of glazes than it is in ceramic bodies from which Sn is absent. Often it is better to do without considering the low Ca content at all.

Sometimes a comparison of spectra gives an hypothetical insight into workshop practises: i) a high Na content may mean that sea salt was added to the glaze; ii) relatively high contents in K and Al together suggest an addition of K-feldspars; iii) P and Ca together suggest an addition of bone dust, maybe to increase the opacification iv) concomitantly high contents of Mg, Al, K and Ca may mean that the workshop master added some clay to the glaze components maybe in hopes of improving its compatibility with the ceramic body.

An important reminder is that when the glaze is fired over the ceramic body and the surface of the ceramic is partially digested by the molten glaze [1] many alien elements, and also more Na, Mg, Al, P, Ca, Ti and Fe are incorporated into the glaze (figure 3). Ti, Fe and other minor-content elements may also be introduced as contaminants e.g. of the sand. Pinpointing a geographical origin from the glaze may be possible if there is information on recognizable patterns in the composition in major elements but resorting to low-content elements may be problematic because lead and tin oxides were usually not of local origin and a number of sources could be used for the alkali oxides, all of them affecting the chemical composition as far as minor or trace elements are concerned.

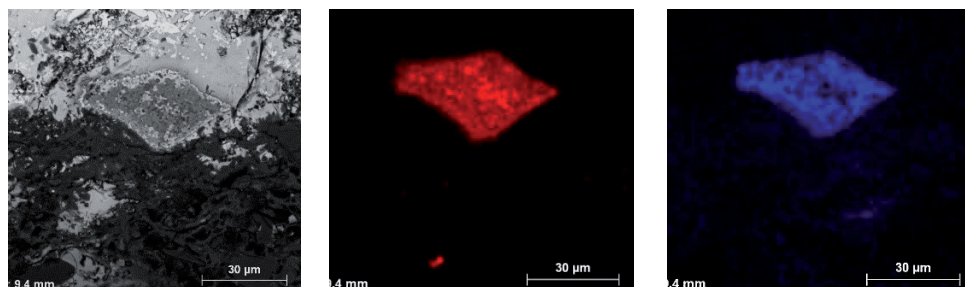


Figure 3a, b, c (left to right): A crystal of ilmenite ($FeTiO_3$) in the process of detaching from the ceramic body and interacting with the glaze. 3a) BSE image of the glaze-ceramic body ceramic body interface; 3b) map of Ti; 3c) map of Fe

The ceramic body

Analysing the ceramic body is rather more complicated than the glaze because the raw materials are often sedimentary marls where many chemical elements are found, including rare-earths brought (in the case of Lisbon) by the rivers from the granite hinterlands of the Peninsula. The major elements routinely found are the main components of aluminium silicates (Na, Al, Si and K) plus P, Ca, Mg, Ti and Fe. Given certain technological procedures, the ceramic body may also incorporate a significant amount of Pb (in some cases up to 8%), particularly in the region nearest to the interface with the glaze. While analysing the ceramic body Pb should be neglected when comparing spectra because of its space-dependence but the fact that a high content of Pb is present may itself be a relevant piece of information on the technology used.

Of the utmost importance when studying the provenance of glazed ceramics is the notion of where the materials were obtained from. For instance due to the good sources of marl clays and sand close to Lisbon it is highly probable that they were obtained locally. In other cases such as with the tiles from Flandres, information exists about the import from other countries of their clays and marls and this information should be therefore taken into consideration ⁽¹⁾.

INSTRUMENTAL MEANS AND SOFTWARE

The direct comparison of spectra can be applied with any instrumental means returning reproducible area or volume compositional spectra, although some technologies are more appropriate than others for the specific purpose pointed here. Energy-dispersive X-ray fluorescence (ED-XRF) is better adapted for the quantification of elements starting with $Z=13$ (aluminium) and therefore misses or is not sufficiently accurate in the cases of $Z=11$ (sodium) and $Z=12$ (magnesium) which are important for clustering, as will be seen. However even XRF spectra obtained with hand-held analysers from the face of tiles can be used, and we have applied that method in a preliminary study (unpublished) aimed at tentatively selecting the cases that would be more thoroughly studied within the present research project. During that preliminary phase we observed that a good fit of replicated XRF surface spectra obtained from white areas of different 16th century azulejo panels was a quite reliable means to pinpoint possible common workshop provenances. The technology has the advantages of application on site and of being wholly non-destructive.

SEM-EDS, with its confirmed repeatability in the quantification of low- Z elements such as Na, Mg and Al, was, however, the preferred technique. However, for it to be useful in graphical comparisons it is very important to consider the peaks of several low-content elements in detail and therefore we should depict the SEM-EDS spectra in a logarithmic scale.

Azulejo panels, loose tiles and fragments were sampled by removing small fractions of the glaze with ceramic body attached. All samples were identified with a code of the type "Az abc/de, in which "abc/de" is a unique alfa-numerical code. The samples were stabilized in resin, cut to obtain a flat section, polished for SEM observation and analysed with EDS.

SEM-EDS observations and analyses were made at the HERCULES Laboratory in Évora using a HITACHI 3700N SEM coupled to a BRUKER XFlash 5010 EDS. The specimens were uncoated and the selection of areas was made in back-scattering mode (BSE) with air in the chamber at a pressure of 40Pa and at an accelerating voltage of 20.0 kV. The acquisition of spectra was done in the same conditions with the detector set at ca. 8 mm distance from the surface of the specimens.

The back-scattering mode relies on electrons from the incident beam that are back-scattered out of the specimen without losing their initial energy. Since heavy elements (those with higher atomic numbers in the Periodic Table) backscatter more electrons than light elements (those with low atomic numbers), areas with heavier elements in their content appear brighter (or "whiter")

in a back-scattered image and thus give information about the composition of the specimen under observation. Since the glaze of an azulejo has a high lead-content and the tin oxide opacifier or the yellow pigments have a still overall higher atomic mass, their image is much whiter than the image of silica or feldspar inclusions in the glaze, or the ceramic body that contain mostly low-atomic weight elements such as silicon, aluminium, potassium and calcium. BSE imaging is therefore ideal to select areas of the glaze as free of inclusions as possible as well as areas of the ceramic body where the glaze has not penetrated.

All EDS spectra acquired were saved in XY-ASCII format (.spx file extension), opened and saved as a graph with the Artax™ spectral analysis PC software as used with the Bruker Tracer III and other XRF analysers of the same brand. All other alternatives are acceptable as long as they allow the saving of an EDS spectrum on a logarithmic scale.

OBTAINING AND INTERPRETING SPECTRA

The glaze

Figure 4 depicts the section of a late 16th century or early 17th century azulejo ready for the acquisition of a compositional spectrum of the glaze by EDS. The rules when choosing the area are three:

- avoid, if possible, areas where the glaze is not perfectly clear (avoid e.g. pigmented or corroded areas);
- avoid as much as possible all inclusions (the darker inclusions are grains of sand and feldspars and if a significative percent of the test area includes e.g. grains of sand that did not take part in the formation of the glaze, then the acquisition will lose reproducibility and any clustering may be less reliable for that reason);
- avoid using point quantification but always area quantification- try and choose a significative area. An area of ca. 0.04 sq mm (200 x 200 μm) or larger would be excellent but areas equivalent to 100 x 100 μm are often satisfactory in a clean glaze- “satisfactory” means that if the acquisition is repeated in a different day, on a different area of the same glaze, with the same instrument within the same operational parameters, the result will be practically the same (“practically the same” being judged by experience, given the uncertainties involved in the acquisition procedure).

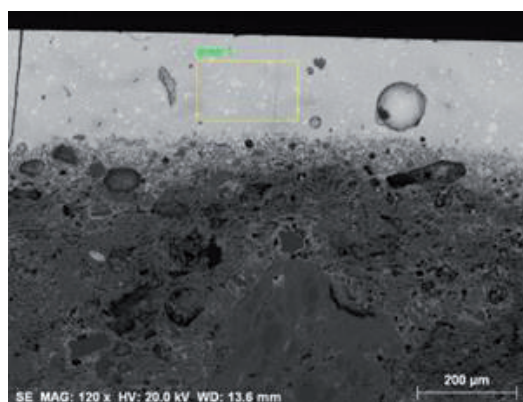


Figure 4a, b (left to right): Tile Az008 and selection of an area ca. 200 x 150 μm for EDS acquisition. Albeit including some tin crystal agglomerations, the selection avoids the darker inclusions and is satisfactory because the tin content will not be used anyway.

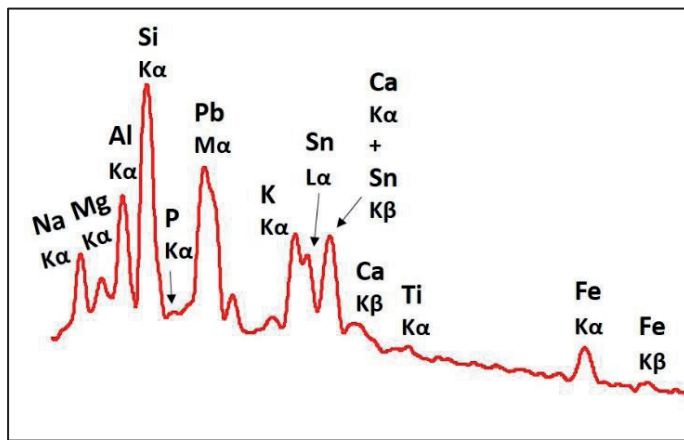
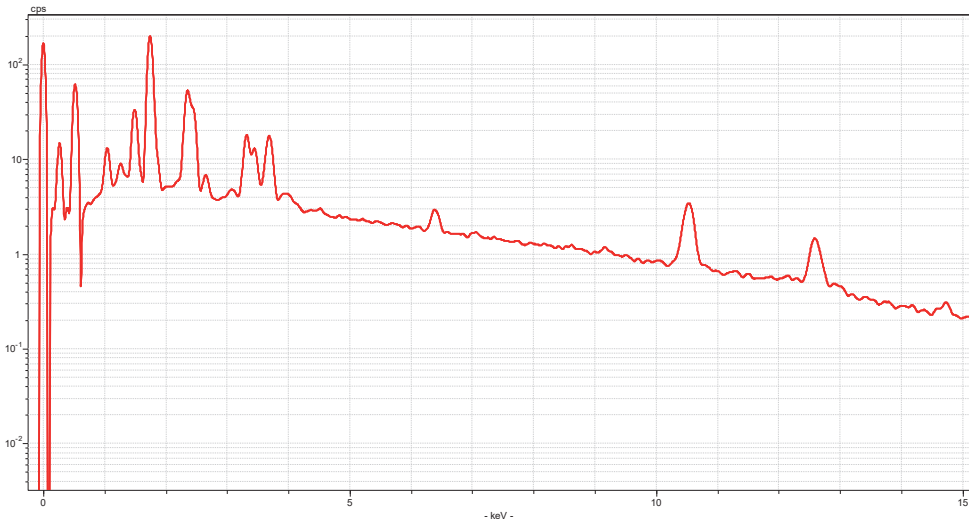


Figure 5a, b (top to bottom): 5a Image of the EDS spectrum of the glaze of a 17th century tile (Az008) from Lisbon workshops; 5b) Span of interest in the spectrum with peaks identified (Sn and Ca will usually not be used).

Figure 5a: depicts the spectrum acquired after smoothing (not strictly necessary) and exporting as indicated before. The relevant part of the spectrum with the peaks that define the elements of interest to our discussion are identified in figure 5b. As explained before, Sn and Ca peaks will not be used in our presentation.

The ceramic body

Figure 6 depicts the section of a specimen obtained from tile Az031A, a fragment of an azulejo from the 1558 Antwerp panels of the Palace of Vila Viçosa, ready for the acquisition of a compositional spectrum of the ceramic body by EDS. The rules when choosing an area are set by the same concerns as for the glaze. Here we should avoid all larger inclusions (small pebbles included in the ceramic bodies are usually no larger than a length of 300 μm in Portuguese azulejos of the late 16th century and the Flemish samples are similar). The size of the area is determined by the size of the inclusions that cannot be avoided. We did a blind test by acquiring spectra for three 500 x 500 μm ceramic body areas of a Portuguese ca. 1570 azulejo without concern for any inclusions and the spectra superimposed almost perfectly. So:

- avoid, if possible, areas including inclusions any of which represents more than ca. 5% of the full area;
- avoid areas too near the glaze-ceramic body interface where the lead may have penetrated (noticeable by the incipient formation of glass or the strikingly lighter colour of the boundaries of inclusions when seen in the back-scattered electrons mode of the SEM);
- never use point quantification but always area quantification- try and choose a significant area. An area of ca. 500 x 500 μm would be excellent but areas equivalent to 300 x 300 μm or even less are often satisfactory.

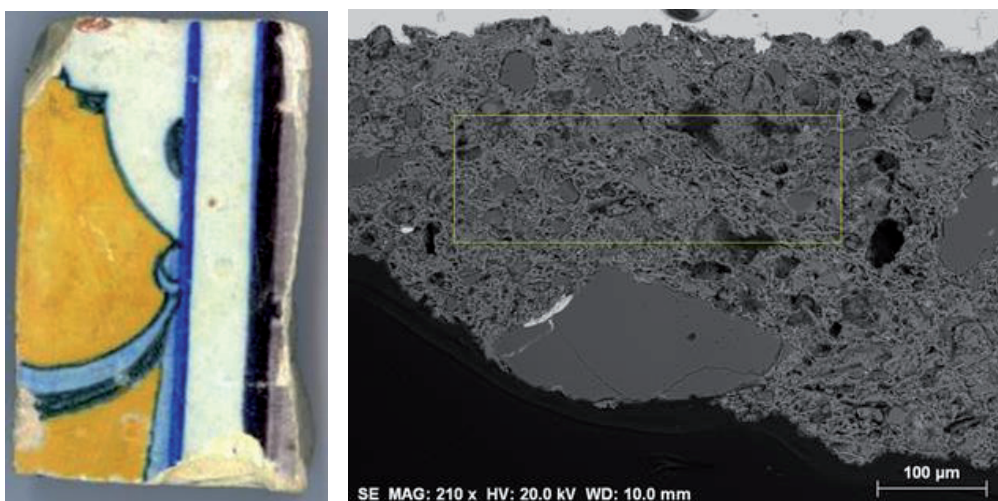


Figure 6a, b (left to right): Tile Az031A and selection of a ceramic body area ca. 350 x 110 μm for EDS acquisition. Albeit including some tiny inclusions, the larger ones were avoided.

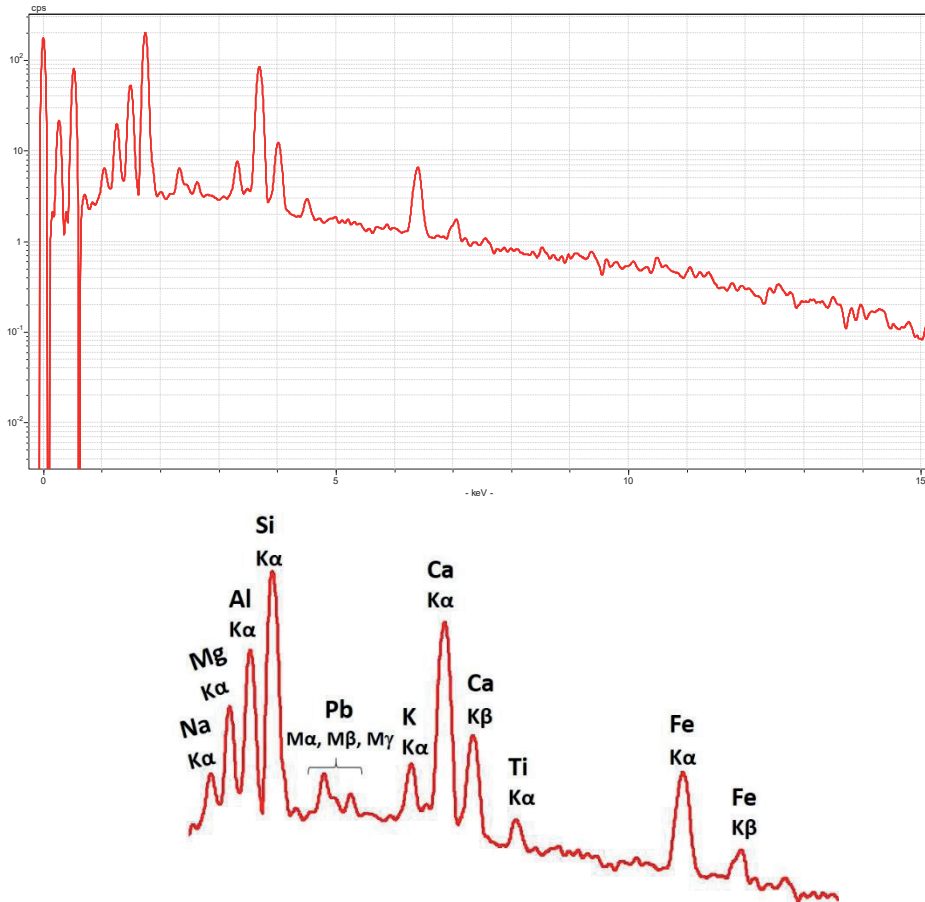


Figure 7a, b (top to bottom): 7a) Image of the EDS spectrum of the ceramic body of a 1558 tile from the workshops of Antwerp (Az031A); 7b) Span of interest with peaks identified. The region marked Pb includes several transitions of the element and should not be considered since it results from the penetration of the glaze into the ceramic during the firing process.

USING SPECTRA

Figure 8 depicts two different Hispano-Moresque tiles (Az65 e Az66) with no relation between them except that they are in the archives of the *Museu Nacional do Azulejo* without a register of the site from which they were removed (the museum was formed much after the tiles were removed from convents and churches sold to private parties in the mid-1800s) and are thought to count amidst the latest to have been imported from the workshops of Seville. The spectra of the two glazes are depicted in figures 8a1 and 8b1. Figure 8c depicts both spectra superimposed. For this purpose, they were made comparable by exactly adjusting the height of the Si peaks and since the baseline differed as a consequence of the varying duration of both acquisitions, the blue spectrum of Az066 was sectioned in two halves just after the Pb peak and without any alteration of the scale the baselines were brought to coincide as closely as possible. After some experience

by the reader about the consequences to spectra of the variability of the glaze compositions, a close observation of figure 8c will strongly suggest, notwithstanding the relevant different in the K contents, that unless direct proof on the contrary (e.g. from historical sources) is available, both tiles should be tentatively clustered together as coming from the same production centre and maybe even the same workshop.

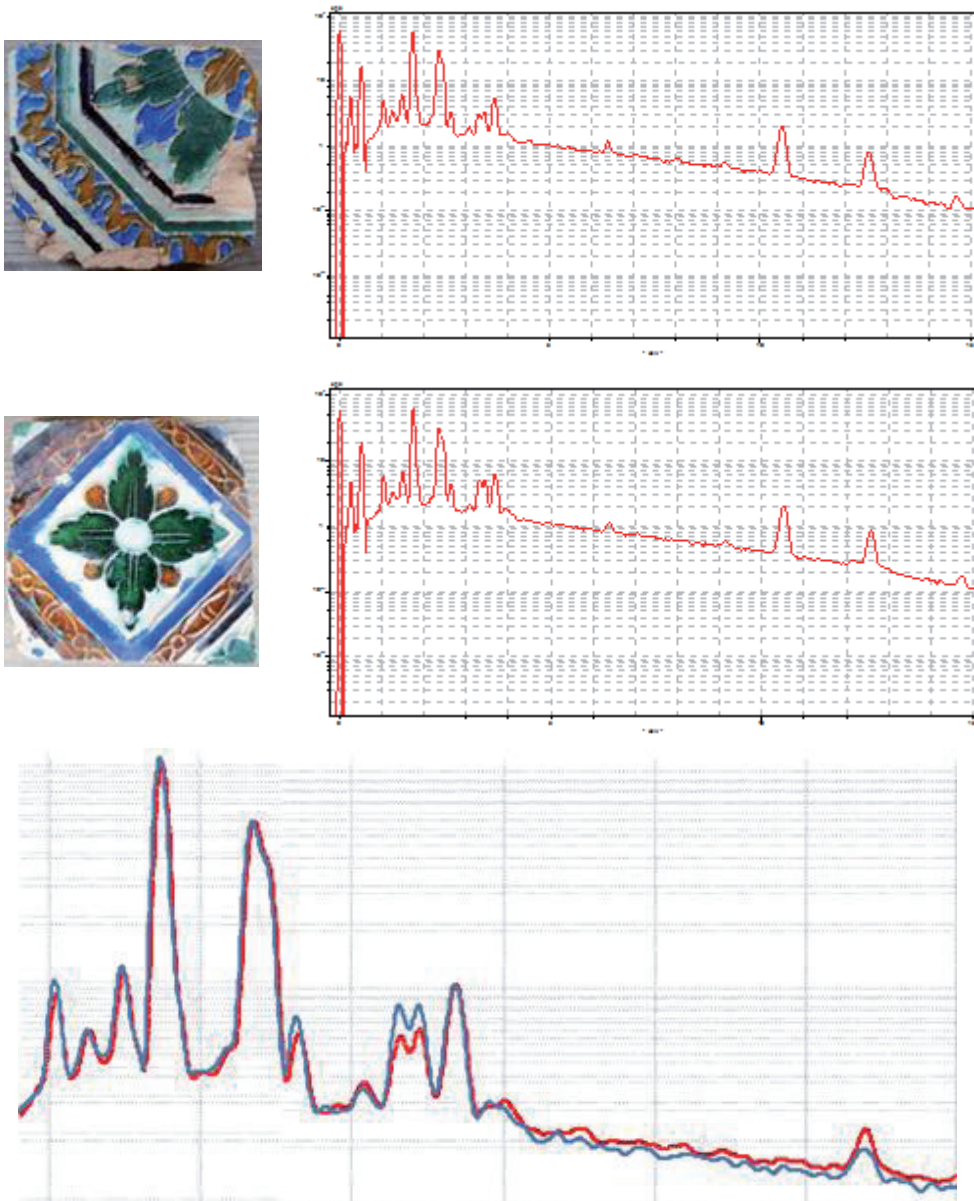


Figure 8 a, a1, b, b1, c (left to right and top to bottom). 8a, a1) Sample Az065 and glaze EDS spectrum. 8b, b1) sample Az066 and glaze EDS spectrum. 8c) EDS Spectrum of Az066 (blue) superimposed over Az065 (red).

On the other side, EDS spectrum of sample Az065 can be compared with the spectrum of Az008 in figure 5a to verify that they are indeed different (Figure 9).

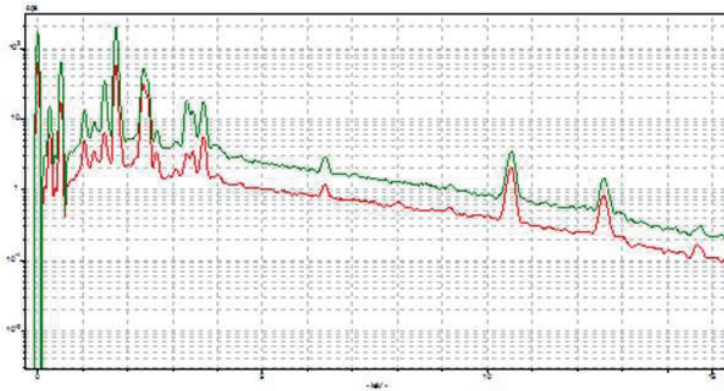


Figure 9: EDS spectra of samples Az065 (red) and Az008 (green)- the peaks of Si have been equalized and, as can be seen, the peaks of Al, Pb and K differ substantially.

CONCLUDING REMARKS

In this communication, we discuss material aspects of glazed ceramics having a counterpart in SEM-EDS spectra and how they should be acquired, interpreted and possibly used as the first stage of a study on provenances without resorting to elemental quantification.

The ceramic bodies of azulejos are made, in most cases, from raw materials locally sourced but clays from the same geologic strata could be used by many workshops. The glazes seem to be more promising whenever it is desired to identify specific workshops or, at least, technological circles sharing the same technology.

This is not a solve-all method but rather one that has borne fruit for an initial screening and the formulation of arguable hypotheses as to the possible clusters. The full method proceeds with a study of the morphology of the glazes, their composition as pertains the Si/Pb ratio, the ceramic bodies again based on the simple but highly significant ratio Ca/Si and the mineral inclusions found in them. But that is a subject needing a few more papers to develop...

Acknowledgements

Dr. Maria de Jesus Monge, Director of the *Museu Biblioteca da Casa de Bragança*, and the parish Priest of *Santo André e Sta. Marinha à Graça* represented by Miguel Angelo da Silva, are gratefully acknowledged for their support and for allowing a limited sampling of loose azulejo fragments and some of the panels in their institutions.

Communication produced as an outcome of Project FCT-AzuRe - Estudos no Azulejo Português para Candidatura a Património da Humanidade (PTDC/EPH-PAT/5096/2014) funded by FCT, the Portuguese Foundation for Science and Technology.

LNEC Research Project 0202/111/19747.

Silvia Pereira acknowledges FCT for her Post-Doc grant SFRH/BPD/116807/2016.

Notes to the text

1. A marl compatible with the glaze is not available everywhere, nor easily recognizable when available. For a time, manufacturers were not aware that they could improve the characteristics

by mixing several clays and adding calcite and sand. In the case of Flanders, local researcher Kate van Lokeren Campagne has found proof that for a time marl was even imported from England [2]. But in the case of Lisbon and Seville there were ample sources of adequate marl available locally and they had been known and used well before faience azulejos were first manufactured.

Bibliographic references

1. MOLERA, J. et al. - *Interactions between Clay Bodies and Lead Glazes*, Journal of the American Ceramic Society, Vol. 84, Nr 5, May2001, pps. 1120-1128.
2. CAMPAGNE, C. - *Een verkeerde loop in 't vuur: an initial investigation into what Dutch archival sources can tell us about techniques and problems in the production of 17th and 18th century Dutch tin-glaze tiles*, in Proc. Int. Conf. Glazed Ceramics in Architectural Heritage-GlazeArch 2015, LNEC, Lisbon 02-03 July, 2015.

Unknown Porto - the use of azulejos in the modern architecture of the northern Portuguese town

Catarina F. M. Geraldès

Departamento de Conservação e Restauro, Faculdade de Ciências e Tecnologia, Universidade NOVA de Lisboa, Caparica, Portugal; Laboratório Nacional de Engenharia Civil (LNEC), Lisboa, Portugal; cgeraldes@lnec.pt

João Manuel Mimoso

Laboratório Nacional de Engenharia Civil (LNEC), Av do Brasil 101, 1700-066 Lisboa, Portugal, jmimoso@lnec.pt

Alexandre N. Pais

Museu Nacional do Azulejo, Rua da Madre de Deus, 4, 1900-312 Lisboa, Portugal, apais@mnazulejo.dgpc.pt

SUMMARY: During the 19th century azulejos started to be used mostly in urban façades, a novel application that opened the way for the “faience towns”. However, by the late 1930s, azulejos were considered something outdated, unworthy of integration in the modern architecture. Later, with the reintroduction of the azulejo in the Brazilian modern architecture during the 1940s, its role as a regional mark rooted in a prestigious history was also recognized by the young Portuguese architects who started integrating them in modern constructions in the first half of the 1950s.

Porto stands as a Portuguese town where modern azulejos were used not only in a striking number of works but also with great creativity. However, the references in the bibliography are scant, compared to Lisbon.

The aim of this paper is to present the use of modern azulejos in Porto, revealing some unknown cases that mark the period in the town. The discussion will be illustrated with an overview of the city’s urban expansion in that period

SUMÁRIO: Durante o século XIX os azulejos começaram a ser utilizados principalmente em fachadas urbanas, uma nova aplicação que abriu o caminho para as “cidades de faiança”. No entanto, no final da década de 1930, os azulejos eram considerados ultrapassados, indignos de integração na arquitetura moderna. Mais tarde, com a reintrodução do azulejo na arquitetura moderna brasileira nos anos 1940, o seu papel como marca regional enraizada numa história de prestígio também foi reconhecido pelos jovens arquitetos portugueses, que passaram a integrá-los nas construções modernas na primeira metade dos anos 50.

O Porto ergue-se como cidade portuguesa onde não só os azulejos modernos eram utilizados num número impressionante de obras, mas também com grande criatividade. No entanto, as referências na bibliografia são escassas, em comparação com Lisboa.

O objetivo deste artigo é apresentar os azulejos modernos do Porto, revelando alguns casos desconhecidos que marcaram o período na cidade. A discussão será ilustrada com uma visão geral da expansão urbana da cidade nesse período

KEY-WORDS: Azulejos / Porto / Modern architecture / Portugal

INTRODUCTION

Whenever they could be afforded, azulejos were one of the favourite materials for the finishing and decoration of walls in Portugal over the centuries [1-3]. Some studies have been undertaken, specifically in the field of art history of the modern movement in Portugal, with the identification of modern azulejos in public spaces in the main Portuguese towns [4-10]. However, information relating to integrated modern azulejos in Porto city is scant.

After the Second World War, the process of urban expansion was particularly fast and intense. Portuguese urbanization was varied with a progressive concentration of people and economic activities along the coastline and around the two main cities, Lisbon and Porto [11]. The concept and style of cities altered from the 1940s to the 1950s due to the many technological, social and cultural transformations [11]. The industrial dynamism felt throughout Europe was reflected in the Portuguese ceramic industry where improvements in technology were matched by the increased integration of azulejos in architecture [12].

As earlier discussed by the authors [13], Portuguese azulejos have a continuous history of architectural integration spanning five centuries. During the 19th century, azulejos started to be used mostly in urban façades, a novel application that opened the way for the growth of “faience towns” in Portugal and Brazil. However, by the late 1930s azulejos were considered something outdated and unworthy of integration in the modern architecture while Modernism did not immediately assimilate their use [14, 15]. With the reintroduction of the azulejo in Brazilian modern architecture during the 1940s, its role as a regional marker rooted in a prestigious history was recognized by young Portuguese architects who started integrating them in modern constructions in the first half of the 1950s.

Porto stands as a Portuguese town where modern azulejos were not only used in a striking number of works but were also used with great creativity. However, written references are scant as compared to Lisbon.

This paper discusses the use of modern azulejos in Porto, illustrating a number of examples of use that marked the period in the city. The discussion will be illustrated with an overview of the city's urban expansion in that period.

OVERVIEW OF PORTO CITY URBAN EXPANSION

Until the middle of the 18th century, the city of Porto was centred within its walls [16, 12]. With the first signs of industrialization in the late 19th century, industrial structures and basic infrastructure began to be built, allowing a fast access to the most remote areas of the city. During the first years of the 20th century, the progress of Porto was marked by a significant urban expansion to the outlying areas with a progressive incorporation of the rural zones [16].

During the 20th century, the city of Porto saw the introduction of schemes, cartographic studies and developments related to the different political periods and inspired by three main figures. The early years of the Republican Regime as seen in the work of Barry Parker¹ who applies the principles of the "Garden City"; in the Estado Novo where the monumentality of the studies of the Italian urbanists, Piacentini² and Muzio³ is seen, and the influence of Robert Auzelle⁴ at the

¹ Barry Parker (1867-1941). British architect was part of the Arts and Crafts Movement, defending the Picturesque and practising the principles of the "Garden City" [17: p. 53].

² Marcello Piacentini (1881-1960). Italian architect and urbanist [17: p. 53, 18: p. 81].

³ Giovanni Muzio 1893-1982) graduated in Milan where he pursued his professional activity [17: p. 53, 18: p.81].

⁴ Robert Azulle (1913-1983). French urbanist [17: p.53].

beginning of the change to a democratic regime, when the premises of the Modern Movement were constructed [17, 19].

In 1932 the engineer Ezequiel de Campos⁵ produced the *Prólogo ao Plano da Cidade do Porto* where he defined a vision of the City as a whole, creating the first truly modern plan for the city. Although this project did not have immediate results, it represents an important stage in the urban development of Porto [16, 19, 22, 23]. In the plan of *Expansão da Cidade do Porto* four circumferences are drawn (figure 1): the first involved the old town, the second the access roads to the city, the third was called the "rural periphery", and the fourth was characterized by the abundance of "rural villages". However, 'de Campos' plan was not followed-up and in the 1930s the city still had a large rural area, while at the same time urban expansion was progressing at great strides although in a chaotic way [16, 19, 22, 23].

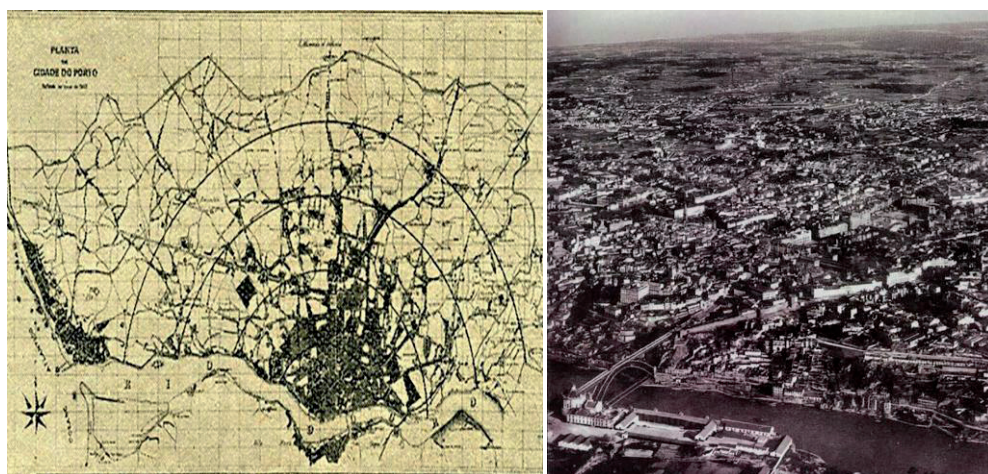


Figure 1: Left: Plant of Porto - Ezequiel de Campos' concentric circumferences [22], right: Panoramic view of Porto city in 1930 [19: p.69]

Under the Estado Novo regime, the cities suffered from the effects of an over-rational approach. Old constructions that were not monumental were unappreciated and the desire to highlight public works, for example with new large avenues, resulted in the sacrifice of older houses [24]. During the 20th century, the urbanism intensified and became crucial in the evolution and organization of the urban expansion of Porto [23].

From the 1940s, architects applied the fundamentals of the *Modern* using a radical and extremely considered approach. These developments enabled modernisation, especially in the field of housing, integrating new materials and construction systems [17].

The fragmented vision of the city gave place to a new perspective and the urban town began to be considered as a whole. To create a *Plano Geral de Desenvolvimento Urbano* the city hall recruited the Italian urban planner Marcello Piacentini, between 1938 and 1940 and later Giovanni Muzio, between 1940 and 1942 as technical consultants [18, 19, 20, 23]. However, the plan was suspended with the death of Duarte Pacheco⁶ in 1943 [19, 23]. A few years later,

⁵ Ezequiel Pereira de Campos (1874-1965). Portuguese engineer, economist, writer and politician [20, 21, 22].

⁶ Duarte Pacheco (1900-1943). Portuguese engineer and statesman. Public Works Minister of *Estado Novo* regime he led the development of a set of works that have changed the country [25, 26].

Antão de Almeida Garret⁷ was in charge of a new study and presented the *Anteplano Regional do Porto*, which was faithful to the ideas of Ezequiel de Campos, proposing an organization based on "nucleus of the neighbourhood" involving housing, services, trade and employment [19, 23]. The city also witnessed a growth in height in a process of "verticalization" that shows its splendour in Porto in the "skyscrapers" of a dozen of floors that were built in the Place D. João V in the late 50's [24].

After the first decades of the 20th century, there was a considerable increase of population in the peri-central and peripheral areas (figure 2). The already industrialized region saw a new phase of development, through the installation of new industries. The creation of these industrial complexes in the areas of expansion of the city lead to the settlement of the working population around these industries, first in the "islands" and later in the working-class districts [17].



Figure 2: Map of the city of Porto in 1950. Dark areas corresponding to the edified zone [28]

In 1956 the *Plano de Melhoramentos para a Cidade*, prepared by the technical services of the City Hall of Porto was introduced to eradicate the "islands" and to solve the problem of economic housing [19]. In 1962 the *Plano Diretor da Cidade* was elaborated by Robert Auzelle and approved in 1964. The plan was an attempt to combat the increase in traffic safeguarding the modernization of the urban network, creating a hierarchical structure [17, 19]. It was undoubtedly this urbanization that most marked the city of Porto in the second half of the 20th century [28].

The Fernando Távora⁸ study in 1969 to save the old part of the City, which Auzelle planned to demolish, raised awareness of the need to preserve the historic urban heritage [19]. Elsewhere the city continued to follow the concept of development of a modern metropolis with an increase in height from 1957 and the number of buildings with more than five floors as a result of the new urban plan approved in the 1952 Regulatory Plan [12, 19]. The azulejo was present as an element in the city architecture, often providing great architectural contrasts [12].

Number of examples of use that marked the period in the city

Porto stands out as a Portuguese town where modern azulejos were used in many cases and with great creativity. The authors believe that these cases are worth paying attention to, not only because they mark an architectonic period in the city, but also because of their originality at the European level.

⁷ Antão de Almeida Garrett (1896-1978). Civil engineer, artillery officer, town planner and teacher [27].

⁸ Fernando Távora (1923-2005). Portuguese architect graduated by the School of Fine Arts of Porto in the year 1952. Member of *Organização dos Arquitectos Modernos* (ODAM) [29, 30].

The discussion considers all use of glazed ceramics with decorative content. Table 1 shows the cases in Porto and Vila Nova de Gaia in a first review (48 and 3 respectively). Figure 3 illustrates the location of each building where integrated azulejos are found, the majority outside the historical centre of the city (the orange circle in the map), may correspond to the expansion experienced in that period from the centre to the periphery.

Table 1: Number of azulejos found in Porto and Vila Nova de Gaia

Cities	Number of cases
Porto	48
Vila Nova de Gaia	3

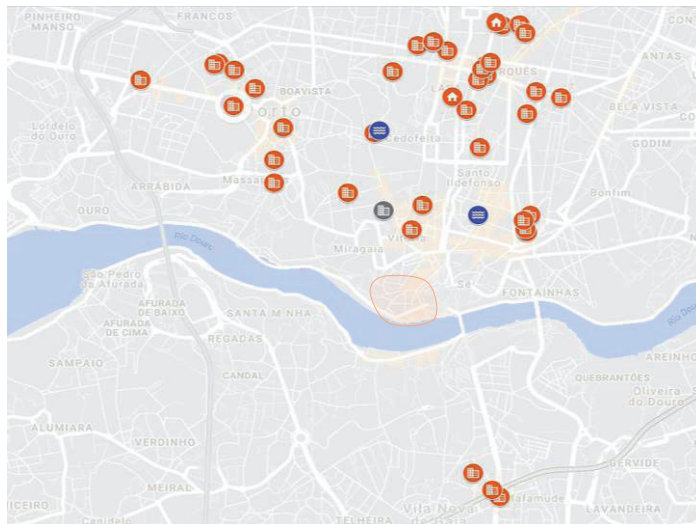


Figure 3: Map of Porto and Gaia with modern buildings with integrated azulejos considered for this paper.

In the following sections, examples of azulejos integrated in the modern architecture of Porto are presented. The relevant lining of walls is considered when the whole façade is finished for a significant percentage of the area, usually more than 50%, intended for aesthetic impact.

All cases are considered from the point of view of a street walker and sometimes a pattern can be found in several different buildings. At least three different buildings in distinct areas with the same pattern were identified, as can be seen in figure 4, where each group was defined with a different colour and the distances of each other vary between 600 m (minimum) to 6 km (maximum).

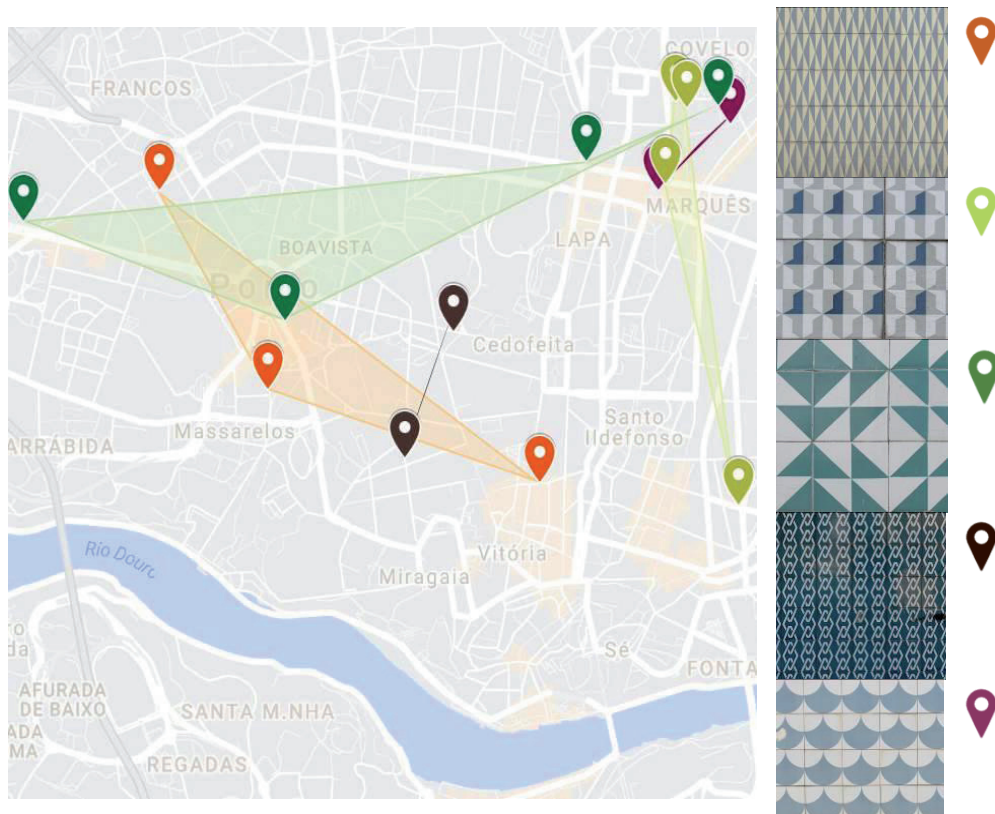


Figure 4: The map of the city of Porto showing different buildings in distinct areas, with integrated azulejos of the same patterns.

The cases that were considered relevant were those made up of a single repetitive pattern, as can be seen in figure 5, those made up of a single pattern but with unlined walls interrupting the continuity of the pattern, sometimes using glass mosaics known in Portugal by the name of the brand *Evinel* (figure 6) or *marmorite*⁹ (figures 7 and 8), which were options that often complemented or replace azulejos as linings of the modern buildings.

⁹ A mixture of aggregates (marble, granite, glass, quartz, ...) with a cementitious binder, a polymeric one, or a combination of both. After drying, it is sometimes polished to obtain a uniform surface [31].

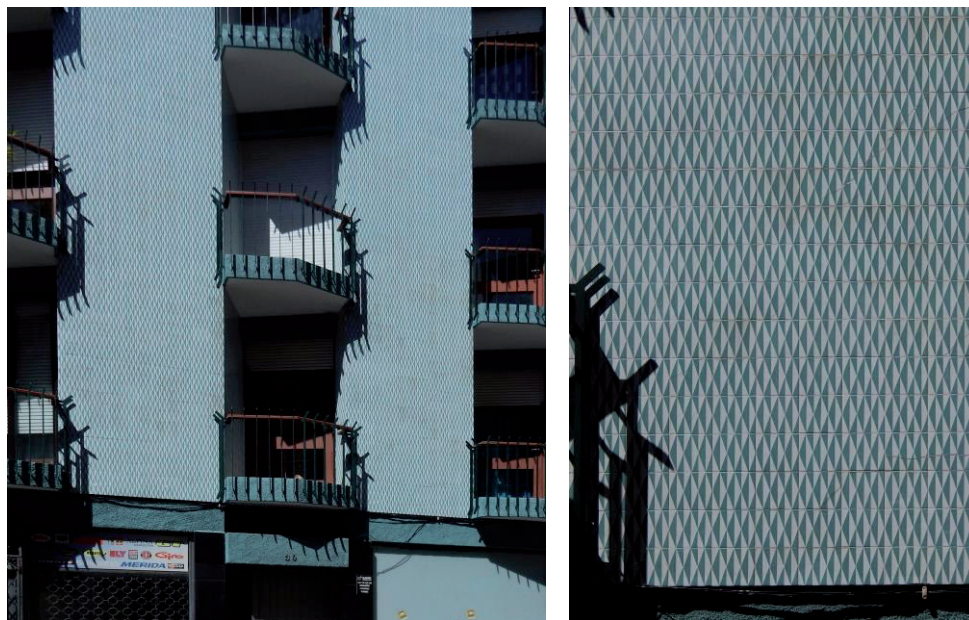


Figure 5: Building in Porto with integrated azulejos. *Rua da Constituição N° 30*

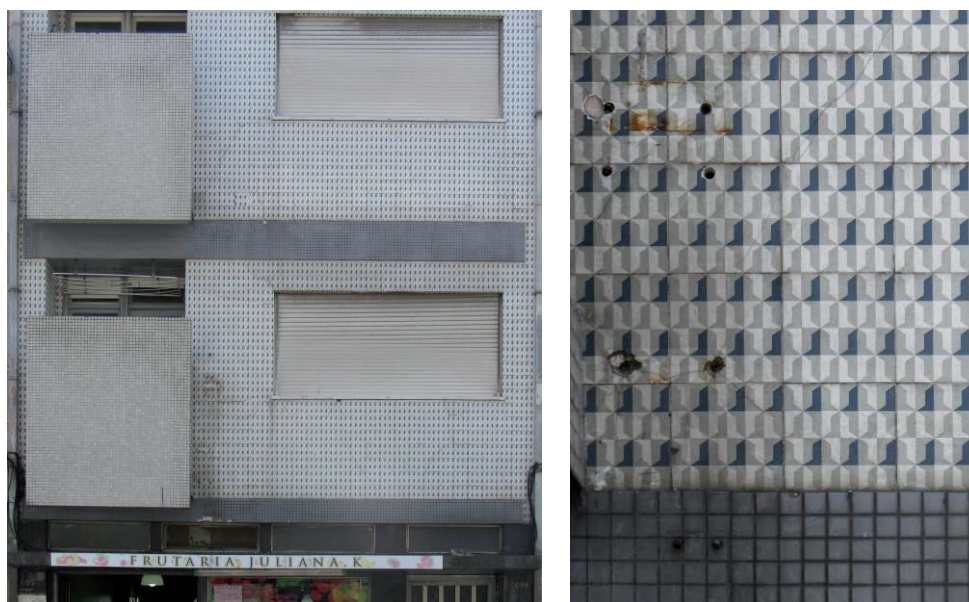


Figure 6: Building in Porto with integrated azulejos. *Rua da Constituição N° 699*

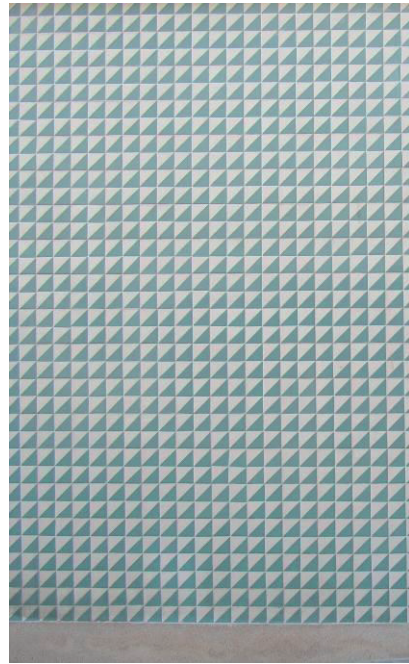


Figure 7: Several buildings in Porto with integrated azulejos. *Rua de Bento Júnior N° 97-99*



Figure 8: *Rua da Boavista N° 433*

The aesthetic value is decreased or even lost when the decorative glazing has decayed, as can be seen in figures 9 and 10. The impression is affected by both the alteration of colours and the design and even by the loss of azulejos themselves (figure 10), modifying the entire composition. Therefore, conservation is essential to enable the recognition of modern azulejo linings as a heritage asset representing a unique movement in Europe.

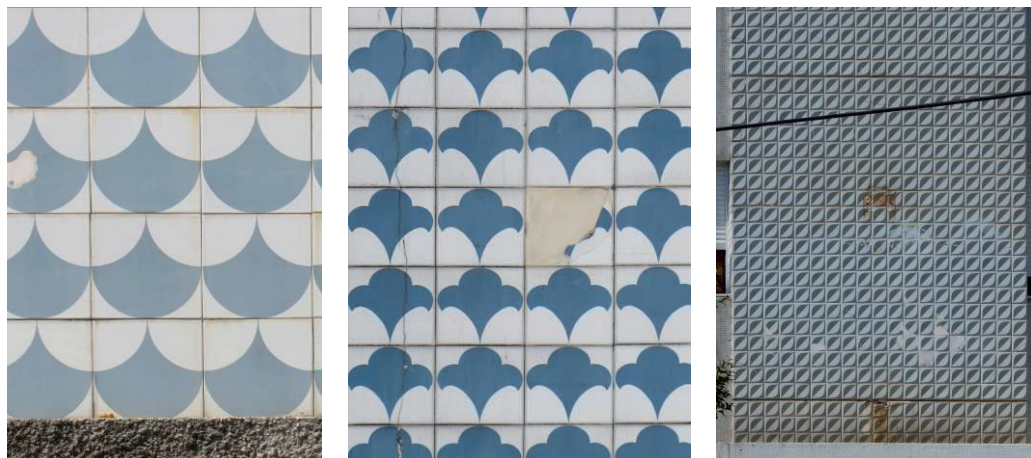


Figure 9: Integrated azulejos in Porto buildings depicting decay. Left: *Rua de António José da Silva N° 60*; center: *Rua da Constituição N° 699*; right: *Rua de 5 de Outubro N° 139*



Figure 10: Rua Faria Guimarães N° 69

One interesting aspect in Porto is the fact that several buildings even have interesting azulejo integrations in streets of low-cost housing where a cheaper solution might be expected.

Most cases depict a modern repetitive pattern, in general with a simple design that may be locally produced and often found at street level or covering most of the façade, as can be seen in the figures 11 and 12 respectively. In most of the cases, such patterns are rarely seen in Lisbon and, as far as we know, they are also not found in the literature.

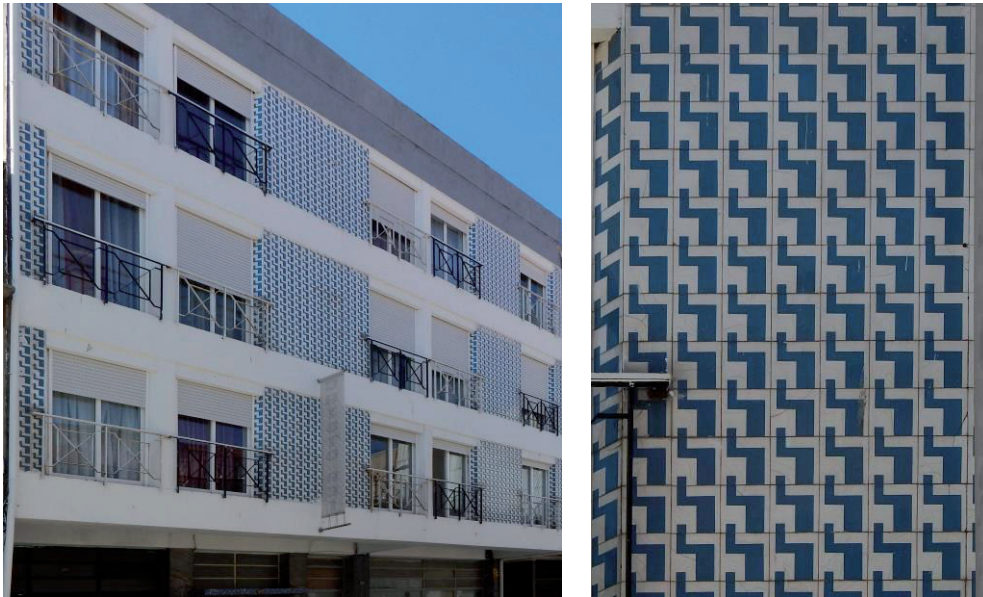


Figure 11: Rua Dr. Alves da Veiga N° 21



Figure 12: Rua de Moreira de Sá N° 145

Interesting examples can be seen in figures 13 and 14 where, although the patterns used in the buildings are the same, the geometry of the application is different, and the perception of the composition is modified in each case. The azulejo used is very simple with a green background and a black line creating the design. By using this design and only changing the position of alternate azulejos, a new and totally different composition is created.



Figure 13: Building with integrated azulejos in *Rua Faria Guimarães N° 257*



Figure 14: Private house with integrated azulejos in *Rua Oliveira Martins N° 19*

In the modern azulejos, it is common to find a pattern that can be used in more than one position, creating a world of possibilities with the same azulejo. Figure 15 shows another example. Three different buildings were found in distinct areas, one being Vila Nova de Gaia, where the azulejos used have the same pattern and colour, white and green, while the position of application is different. In each case, the impact on viewers is very different as if it was a "game of position".

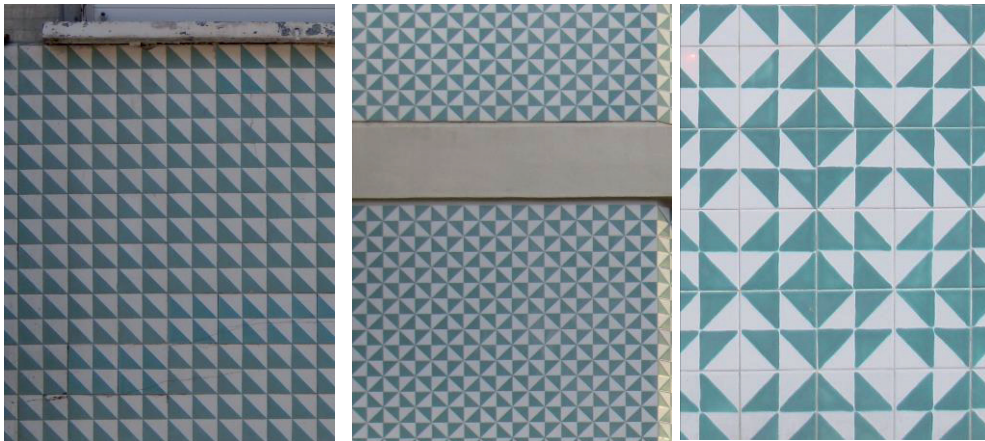


Figure 15: Three geometries of application with the same pattern. Left: *R. de Júlio Dinis N° 896*; centre: *Av. da Boa Vista N° 1624*; right: *Av. da República N° 1473 (Vila Nova de Gaia)*

Figures 16 and 17 show two examples where the integration of azulejos is somewhat different. In the first, the use of glazed ceramics with a protruding front and in shades of the same colour creates texture, variety and interest in façade areas that would otherwise be rather plain and uninteresting.



Figure 16: Building with integrated azulejos in *Rua de João das Regras N° 101*

In the second case, the azulejo has lines and shades in the same colour that create a pattern when seen from a distance.



Figure 17: *Praça Guilherme Gomes Fernandes N° 90*

The following images demonstrate several modern azulejos with a single repetitive pattern integrated in buildings in the town. The patterns found are in general very simple and the beauty of the entire set results from the “game” of colours, or the manner in which the lined areas are harmonized with the rest of the façade.

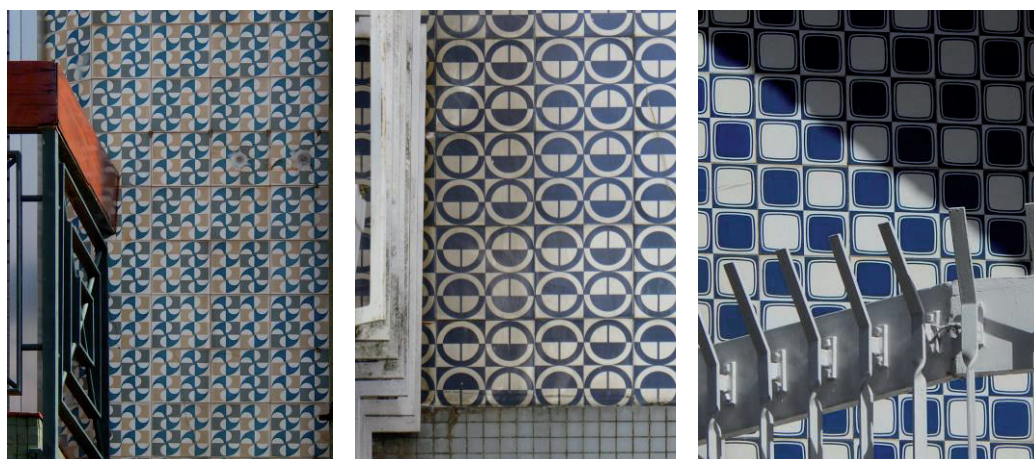


Figure 18: Left: *Rua do Bonjardim N° 832*; center: *Rua das Doze Casas N° 83*; right: *Rua de João Pedro Ribeiro N° 729*

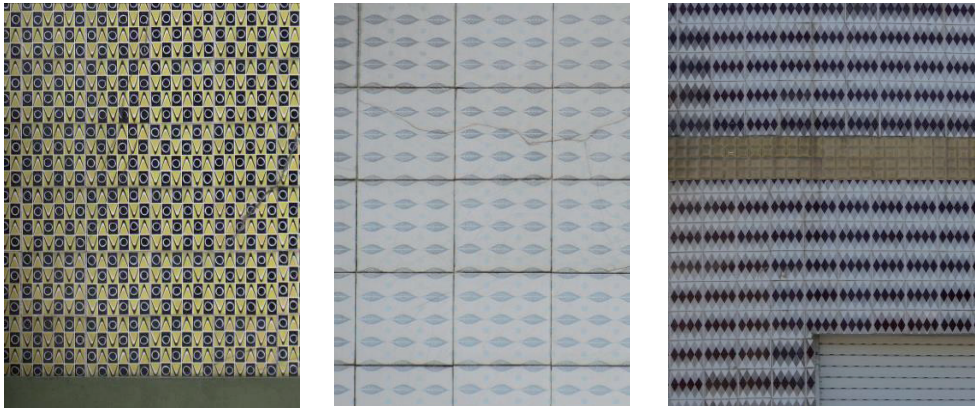


Figure 19: Left: *Rua Faria Guimarães N° 363*; center: *Rua Faria Guimarães N° 471*; right: *Rua dos Vanzeleros N° 334*

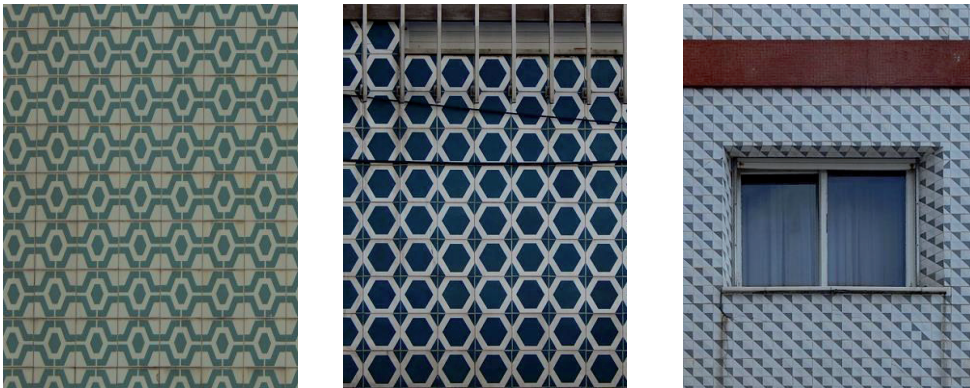


Figure 20: Left: *Rua de João das Regras N° 94*; center: *Rua de Latino Coelho N° 26*; right: *Rua do Bonjardim N° 1206*



Figure 21: Left: *Rua do Bom Sucesso N° 35*; center: *Rua Dr. Alves da Veiga N° 89*; right: *Rua de Cunha Júnior N° 50*

A slightly different case often not considered to be attractive (which is subjective) is the example in figure 22, where the building is lined with a rather uninteresting pattern and colour often seen in interiors. However, the entire ensemble acquires an inevitable aesthetic dimension for the viewer. Through the use of bold colours, yellow and orange, and because the lining covers most of the façade, it imposes itself on passers-by and, even though it cannot be really considered a modern pattern, the conception is relevant in terms of the impact created.



Figure 22: Building with integrated azulejos in *Rua do Monte Cativo N° 81*

CONCLUSION

Azulejos have been one of the favourite materials for finishing and decorating buildings in Portugal over the centuries. However, there has been scant mention of integrated modern azulejos in the town of Porto.

In this paper, the authors present a number of examples of integrated modern azulejos in the architecture of Porto. Due to urban expansion, which was particularly fast after the Second World War, Porto expanded significantly to the periphery during the second half of the 20th century. As reviewed by the same authors elsewhere [13] Brazilian modern architecture, influenced by an unexpected recommendation by none other than Le Corbusier, re-introduced the use of azulejos in the 1940s leading to the integration of Portuguese modern buildings starting in the first half of the 1950s.

The modern azulejos were used with great creativity in Porto. It was possible to verify that the azulejo is a predominant element of several buildings in the city, often in magnificent architectural contrasts, of which 48 cases located in diverse areas of the city (most of them located outside the historical center), were selected to provide a list of relevant cases in Portugal.

Sometimes, a single repetitive pattern is found in more than one building and with different choice of position, creating new compositions. Occasionally the glass mosaics *Evinel* or even *marmorite* were used in harmony with azulejos where they sometimes complement each other in modern buildings. Modern azulejos with a decorative content significantly modify the appearance of buildings, creating an aesthetic impact that enhances their uniqueness.

Acknowledgments

The authors acknowledge the Portuguese Science Foundation (FCT) for the funding of PhD grant PD/BD/114408/2016 (Catarina Geraldês) and Project FCT-AzuRe - Estudos no Azulejo Português para Candidatura a Património da Humanidade (PTDC/EPH-PAT/5096/2014) for supporting this research.

Bibliographic references

- [1] HENRIQUES, Paulo et al. - *O Azulejo em Portugal no século XX*. No. of edition ISBN 972.787.009.0, Editor Inapa, Lisboa, 2000
- [2] AMARAL, Ricardo - *Arquitectura & Cerâmica: o espaço da tradição mural na contemporaneidade*. Master dissertation. Porto University, ID: 2015
- [3] ALMEIDA, Ana - *Da cidade ao Museu: uma proposta de itinerário pela azulejaria de autor na Lisboa da segunda metade do século XX*, Master dissertation, Lisbon University, 2009
- [4] SAPORITI, Teresa - *Azulejos de Lisboa do século XX*. No. of edition 437, Editor Porto: Afrontamento, Lisboa, 1992, ISBN 972-36-0199-0
- [5] BURLAMAQUI, Suraya - *Cerâmica Mural Portuguesa Contemporânea, Azulejos, Placas e relevos*. ISBN 972-564-270-8, Editor Quetzal, Lisboa, 1996
- [6] AMORIM, Sandra - *Azulejaria de Fachada na Póvoa de Varzim (1850-1950)*. No. of edition ISBN 972-97058-0-1, Editor Póvoa de Varzim, 1996, 2001
- [7] SAPORITI, Teresa - *Azulejos Portugueses, padrões do século XX*. No. of edition ISBN 972-97653-1-6, Editor Publilimpresores, Artes Gráficas LDA., Lisboa, 1998
- [8] CALADO, Rafael Salinas et al. - *O Revestimento Cerâmico na Arquitectura em Portugal*. No. of edition ISBN 972-8095-45-7, Editor Estar, Lda, Lisboa, 1998
- [9] SANTOS, Rui; PORFÍRIO, Luís; MECO, José - *Querubim Lapa Cerâmicas*. No. of edition ISBN 972-797-001-X, Editor Inapa, Lisboa, 2000
- [10] NERY, Eduardo - *Apreciação Estética do Azulejo*. No. of edition ISBN 978-972-797-150-3, Editor Inapa, Lisboa, 2007
- [11] DELGADO, Carlos - *Metapolis do Porto: expansão urbana em áreas de forte aptidão agrícola. Cidades e Ordenamento do Território*. Actas do XII Colóquio Ibérico de Geografia, ISBN 978-972-99436-5-2 (APG); 978-972-8932-92-3 (UP-FL), 2010
- [12] ARAÚJO, Sara - *A conservação de azulejo de fachada na cidade do Porto. As práticas de reabilitação de edifícios com fachadas azulejadas*. Master dissertation, Instituto Politécnico de Tomar, URI: <http://hdl.handle.net/10400.26/13739>, 2015
- [13] GERALDES, Catarina; PAIS, Alexandre; MIMOSO, João Manuel - The Integration of Azulejos in the Modernist Architecture of Portugal as a unique case in Europe, In: M. Menezes, D. R. Costa, J. D. Rodrigues (eds.) Congress Book Proceedings for the IPERION CH international conference - Intangibility Matters, Lisbon, 29-30 May 2017, pp 139-147
- [14] SILVEIRA, Marcele - *O azulejo na modernidade Arquitetónica (1930-1960)*. Master dissertation, São Paulo University. DOI: 10.11606/D.16.2008.tde-25032010-154757, 2008

- [15] WANDERLEY, Ingrid - *O azulejo na arquitectura brasileira. Os painéis de Athos Bulcão*. Master dissertation, USP. DOI: 10.11606/D.18.2006.tde-10112006-142246, 2006.
- [16] FERREIRA, Nuno - *A arquitectura rural na cidade do Porto na primeira metade do século XX: Construção de quintas em contexto de expansão urbana* [Online] http://www.citcem.org/3encontro/docs/pdf/part_011/Nuno%20Ferreira.pdf [Accessed 25 / 06 / 2018].
- [17] FERREIRA, Nuno - *Entrepasto Frigorífico do Peixe de Massarelos Um dos ícones da arquitectura modernista portuense, vol. 1*. Master dissertation, Porto University ID: <http://hdl.handle.net/10216/56082>, 2010.
- [18] AMORIM, Maria - *Porto, a cidade planeada – 1930/1980: permanências/ inovações no processo e formas urbanas*. Master dissertation, Porto University, ID: <http://hdl.handle.net/10216/11947>, 1998.
- [19] GRAVATO, Maria - *Trajeto do Risco Urbano. A arquitectura da cidade do Porto, nas décadas de 30 a 50 do século XX, através do estudo do conjunto da avenida dos aliados à rua de Ceuta, vol. 1*, Master dissertation, Porto University, ID: <http://hdl.handle.net/10216/19456>, 2004.
- [20] [Online] Published by FIGUEIREDO, Ricardo - *Os Planos para o Porto – dos Almadás aos nossos dias 7 V. Os Planos dos Italianos para o Porto 1*. November 2010 [online]: <http://doportoenaoso.blogspot.com/2010/11/os-planos-para-o-porto-dos-almadas-aos.html> [Accessed 25 / 06 / 2018].
- [21] [online] *Ezequiel de Campos* - https://pt.wikipedia.org/wiki/Ezequiel_de_Campos [Accessed 25 / 06 / 2018].
- [22] [Online] Published by FIGUEIREDO, Ricardo - *Os Planos para o Porto – dos Almadás aos nossos dias 6 V. O Prólogo ao Plano da Cidade do Porto por Ezequiel de Campos 1932*. September 2010 [online]: <http://doportoenaoso.blogspot.com/2010/09/os-planos-para-o-porto-dos-almadas-aos.html> [Accessed 25 / 06 / 2018].
- [23] FERREIRA, Nuno; ROCHA, Manuel - *Etapas de consolidação da paisagem urbana do Porto contemporâneo, da programação dos Almadás ao plano de 1952*. CEM N.º 5/ Cultura, ESPAÇO & MEMÓRIA, pp 191-230.
- [24] FERNANDES, José - *Porto: um percurso urbano*. Porto University / CEGOT [online]: <https://pt.scribd.com/document/177912291/Porto-Percurso-Urbano> [Accessed 25 / 06 / 2018]
- [25] [online] https://pt.wikipedia.org/wiki/Duarte_Pacheco [Accessed 25 7 06 / 2018].
- [26] [online] <http://ensina.rtp.pt/artigo/duarte-pacheco/> [Accessed 25 / 06 / 2018].
- [27] [online] Published by Antigos Estudantes Ilustres da Universidade do Porto - *Antão de Almeida Garrett* – https://sigarra.up.pt/up/pt/web_base.gera_pagina?p_pagina=antigos%20estudantes%20ilustres%20-%20ant%C3%A3o%20de%20almeida%20garrett [Accessed 25 June 2018].
- [28] [Online] Published by FIGUEIREDO, Ricardo - *Os Planos para o Porto – dos Almadás aos nossos dias 8 (I parte). O Plano Director da Cidade do Porto, 1962 Robert Auzelle*. April 2011 [online] <http://doportoenaoso.blogspot.com/2011/04/os-planos-para-o-portodos-almadas-aos.html> [Accessed 25 / 06 / 2018].
- [29] [online] https://pt.wikipedia.org/wiki/Fernando_T%C3%A1vora [Accessed 25 / 09 / 2018].
- [30] [online] https://pt.wikipedia.org/wiki/Organiza%C3%A7%C3%A3o_dos_Arquitectos_Modernos [Accessed 25 / 09 / 2018].
- [31] [online] <https://pt.wikipedia.org/wiki/Marmorite> [Accessed 25 / 06 / 2018].



LABORATÓRIO NACIONAL
DE ENGENHARIA CIVIL



IPERION CH

 **FCT** AzuRe



PATRIMÓNIO CULTURAL
Director-Geral do Património Cultural



#EuropeForCulture

ISBN 978-972-49-2301-7



9 789724 923017

AV DO BRASIL 101 • 1700-066 LISBOA • PORTUGAL
tel. (+351) 21 844 30 00 • fax (+351) 21 844 30 11
lnecc@lnecc.pt www.lnecc.pt

